

NuTone

SERVICE MANUAL

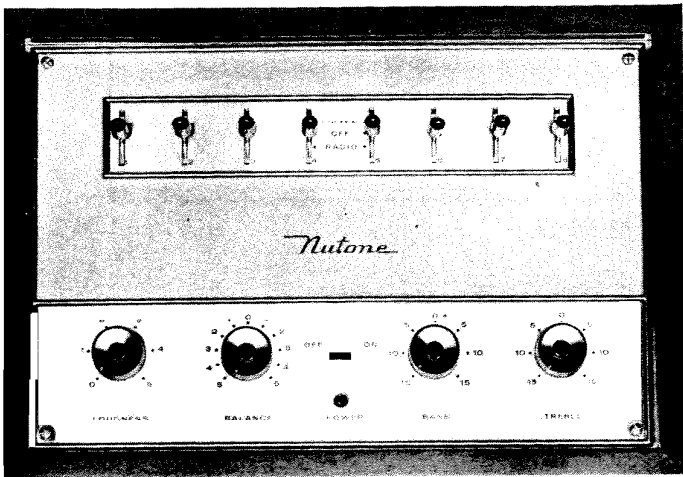

Stereo and Intercom High Fidelity Music System

Models 2401-2402

NuTone Housing Products

MADISON & RED BANK ROADS

•

CINCINNATI, OHIO 45227

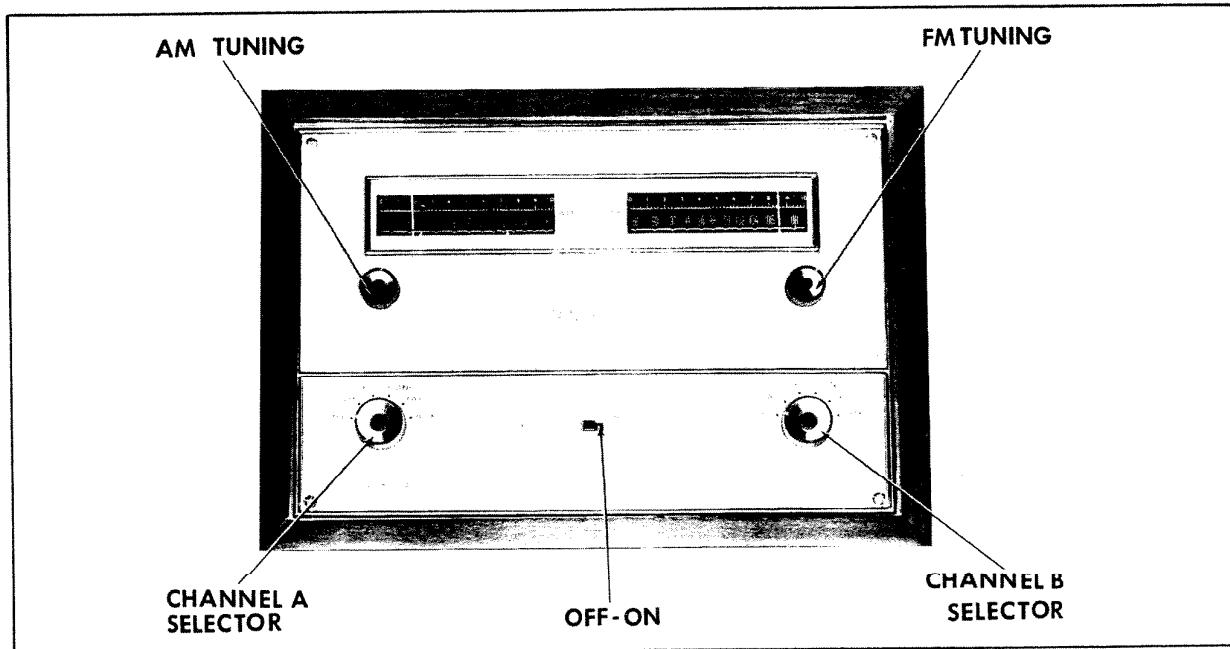

Fig. 1. AM-FM Tuner Front Panel.

COMPLETE SYSTEM CHECK-OUT PROCEDURE

1. Set Off-On switch of amplifier to On position. The pilot light should come on.
2. Set Channel-A and B selector switches (on Tuner) to Phono position. Place a stereo record on changer, and turn changer on.
3. Set Remote Station selector switches to the Radio position. Turn Loudness control clockwise to desired listening level. Adjust Balance control to balance amplification from the Channel-A and -B speakers. (The speaker volume controls on the speaker control panel will also have to be balanced.) Adjust Bass and Treble controls for best tonal effect.
4. Turn off record changer. Turn Channel-A selector switch to AM position, and Channel-B selector switch to Off position. Set Off-On switch of tuner to On. Check AM reception.
5. Turn Channel-A selector switch to FM position, and check FM reception.
NOTE: Check all remote speaker stations after performing each of Steps 4, 5, and 6.
6. Move the Talk-Listen switch (on speaker with controls, or on Remote Control Panel, if used) to the Talk position. Hold in this position while talking. Check all remote stations for reception. Release switch to Listen position, and check all remote stations for replies.
NOTE: If intercom volume is low, this may be due to high level AM or FM signals. Adjust R1 and R2 on the tuner chassis (see Fig. 26) until the amplifier Loudness control provides a normal listening level at approximately the No. 2 position.
7. Set all Remote Station selector switches, except the one being used, to the Listen position. Check for reception from all remote stations.
8. Return the Remote Station selector switches to the Radio position. Move the Talk-Listen switch and Inside-Outside switch (on speaker control panel) to the right. Hold in this position while talking, to check operation of outdoor speaker. To listen, release only the Talk-Listen switch to the Listen position, and check for reception from outdoor speaker.

TUNER DISASSEMBLY INSTRUCTIONS

Partial Disassembly (Minor Servicing - Tubes, etc.)

1. Remove the two function switch knobs and the two tuning knobs.
2. Remove the four brass screws from the corners of the front panel. (See Fig. 12.)
3. Remove the front panel.
4. Remove the four brass screws from the front of the unit. (See Fig. 10.)
5. Slide unit out until it rests against the slide stops and tilt it forward from the top. Unit will now rest securely at a 45° angle. (See Fig. 9.)
NOTE: Unit can be operated from this position.

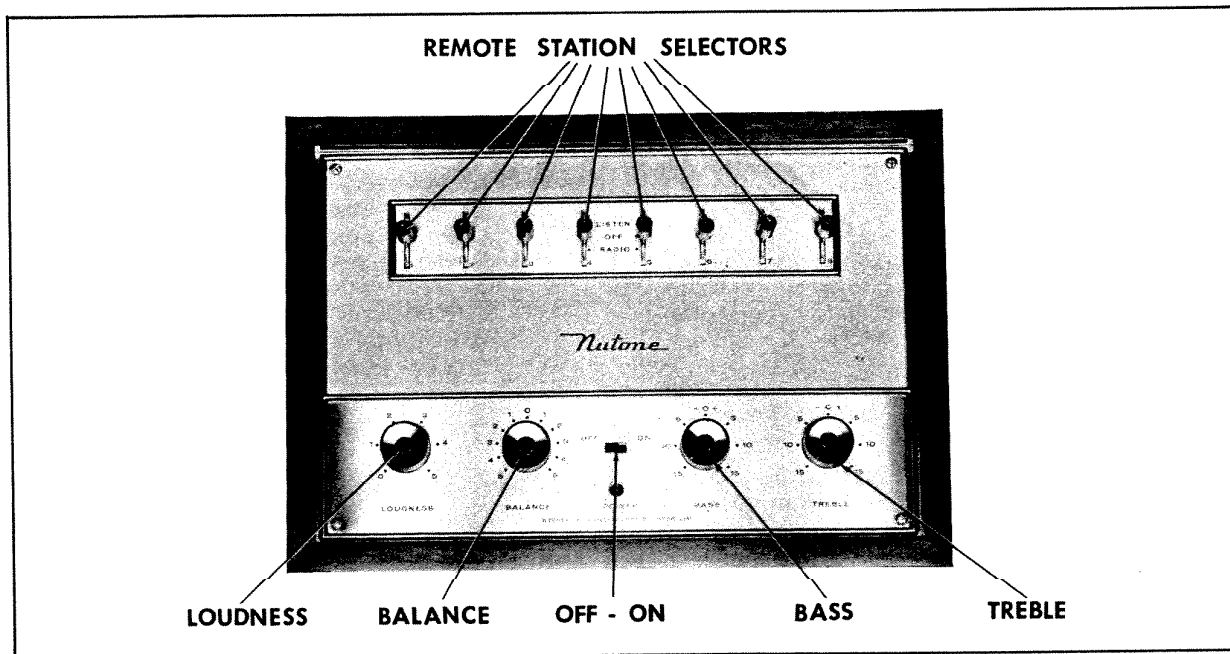

Fig. 2. Amplifier Front Panel.

TUNER DISASSEMBLY INSTRUCTIONS (Cont'd)

Complete Disassembly

1. Follow Steps 1 through 6 under "Partial Disassembly."
2. Remove AM antenna lead (blue) and FM antenna lead (twin) from antenna posts.
3. Remove power plug from the tuner junction-box receptacle.

4. Remove all plugs from the signal output jacks on the bottom of the tuner. Be sure that identification tags are on each cable.
5. Remove the tuner from the rough-in box by tilting back to vertical position and simultaneously lifting and pulling forward until it clears the slide-stop mounting brackets.

NOTE: Reverse the foregoing procedure to assemble the unit.

AMPLIFIER DISASSEMBLY INSTRUCTIONS

Partial Disassembly (Minor Servicing - Tubes, etc.)

1. Remove the four control knobs and the eight station-selector knobs.
2. Remove the four brass screws from the corners of the front panel. (See Fig. 8.)
3. Remove the front panel.
4. Remove the four brass screws from the front of the unit. (See Fig. 6.)
5. Remove the six dot fasteners to release the front amplifier insulator (cardboard). (See Fig. 6.)
6. Slide unit out until it rests against the slide stops, and tilt it forward from the top. Unit will now rest securely at a 45° angle. (See Fig. 4.) NOTE: Unit can be operated from this position.

2. Remove six Phillips head screws holding terminal board to chassis. (See Fig. 4.) Disconnect the 4-pin plugs at each end of the terminal board. Remove terminal board from chassis.

3. Remove power plug from the amplifier junction-box receptacle.
4. Remove the two plugs from the channel A and B input jacks, and the two plugs from the tape deck output jacks.
5. Remove the amplifier from the rough-in box by tilting back to vertical position and simultaneously lifting and pulling forward until it clears the slide-stop mounting brackets.

6. Remove the four Phillips head screws holding the control subchassis, for easy access to control wiring.

NOTE: Reverse the foregoing procedure to assemble the unit.

Complete Disassembly

1. Follow Steps 1 through 6 under "Partial Disassembly".

OPERATING AMPLIFIER FOR BENCH SERVICING

To service amplifier after it is removed from the "A" box, connect as follows:

1. To apply power to the amplifier, connect a TV "cheater cord" to pins 1 and 4 on the power input plug.
2. Connect the output of an AM-FM tuner, record player, or audio generator to the left- or right-channel input jack (depending upon the channel to be checked).
3. Connect a speaker across the blue and white leads of the output plug (points AZ1 and AZ2, Fig. 29) to check the channel-A output. Connect it across the gray and red leads (points BZ1 and BZ2) to check the channel-B output.
4. To check the intercom, connect a speaker across the channel-A output (points AZ1 and AZ2). Connect a second speaker, or audio generator, across the blue and red leads of the input plug (points X1 and X2, Fig. 29). Short the lug at the junction of R100 and R101 (point Y) to ground, to energize the relay. Talk into speaker, or turn generator on.

TROUBLESHOOTING

Following is a useful trouble chart. Different positions of the Function switches and the Remote Station selector switches connect circuitry common to several operations. Therefore, in some cases one trouble may cause malfunctioning in several positions of the Function switches, the Remote Station Selector switches, or both.

In order to reduce the number of check points for a given trouble, it is assumed that the interunit signal and power cables are correctly connected (Figs. 21 and 22), and that the Amplifier-Remote Station wiring is correct (Fig. 14).

TROUBLE CHART

Trouble	Cause	Suggested Check Points
Tubes do not light in amplifier or AM-FM tuner, record player and tape deck motors inoperative. Power switches M13 and M6 in ON position.	Blown power fuse.	Amplifier power junction box. (Fig. 21).
Tubes light in amplifier but not in AM-FM tuner.	Blown fuse M1.	AM-FM tuner chassis (Fig. 33).
Tubes light in AM-FM tuner, but not in amplifier.	Blown fuse M11.	Amplifier chassis (Fig. 34).
All tubes light but no sound from any source. Switches and controls set for normal operation.	Amplifier dead.	Check tube V20. (Fig. 34).
All tubes light but no output from AM-FM tuner. Switches and controls set for AM or FM operation.	Tuner dead.	Check tubes V1 through V10. Check voltage and resistance readings, as designated on the tuner schematic (Fig. 33).
No sound through Channel-B speakers. Switches and controls set for Stereo and Phono operation.	Channel-B amplifier dead.	Check tubes V13 and V16 through V20. Check voltage and resistance readings as designated on the amplifier schematic. (Fig. 34). Check Function switch contacts. Check Remote Station selector switch contacts.
Same as foregoing, except no sound through Channel-A speakers.	Channel-A amplifier dead.	Same as foregoing except check tubes V12 through V15.
Stations cannot transmit. All other operations normal. Station selector switches in Stereo-Intercom position.	Intercom preamplifier dead.	Check tube V11 and input transformer T3.
Low intercom volume.	Tuner volume level controls set too high.	Adjust R1 and R2 on tuner (Fig. 26) until amplifier Loudness control is set at approximately the No. 2 position for normal listening.
One or more stations transmit but do not receive. Switches and controls set for normal operation.	Switch contacts dirty, or speaker volume control open.	Check Station Selector switches in amplifier (Fig. 34) for affected Remote Station. Check Listen-Talk switch M24 and volume control R119 and R120 at Remote Station position (Fig. 35).
One or more stations receive but cannot transmit. Switches and controls set for normal operation.	Listen-Talk switch dirty or has broken contacts.	Check switch M24 (Fig. 35) at the affected Remote Station positions.
One or more stations can neither transmit nor receive.	Speaker voice coil open.	Check speaker at the affected Remote Station position (Fig. 35).
One or more Channel-B speakers do not operate. Switches and controls set for Stereo operation.	Open voice coil.	Check slave speakers at affected Remote positions.
One channel operates, the other one weak and distorted. Switches set for Phono operation.	Phono output leads to Tuner reversed.	Reverse Phono leads at Tuner Phono input.

INSTALLATION INSTRUCTIONS

MODEL 2401 AMPLIFIER

Mount the Amplifier Chassis

Position mounting studs into slot provided in the bottom of the extension brackets and push chassis into place.

Pull the set outward until the mounting stud stops against front edge of the mounting slot in the extension bracket. Tilt the unit outward. The back mounting stud fits into the diagonal slot in the extension bracket. This holds the unit at an angle exposing the terminal strips at top of chassis (Fig. 3).

Power Cord

Plug power cord into receptacle in junction box. (Fig. 4.)

Connect Remote Speaker and Signal Leads

IMPORTANT: Make sure the wires are not shorted from one terminal to another.

The terminal strip is divided into four sections.

1. Two top screws of left terminal for door remote.
2. Two bottom screws of left terminal for electronic chimes.
3. Four sets of 8 screws on the left for speakers 1 to 4.
4. Four sets of 8 screws on the right for speakers 5 to 8.

A color code designation strip is located along the back edge of the terminal strip plate. Connect the door speaker wires to the top two terminals on the left side of the panel. (Fig. 5.)

Connect the 8-wire cable to the terminal strip. (Fig. 5). Be sure to connect wires to their corresponding color terminals (red to red, black to black, etc.)

After all speaker wires have been connected, push the chassis into the rough-in box. Fasten in place with screws through mounting tabs on side of chassis. (Fig. 6.)

Plug the signal leads to the AM-FM Tuner into the channel A and B Input jacks. Plug the two signal leads to the tape deck into the channel A and B Tape Output jacks. (Be sure they are pushed firmly into the jacks.) (Fig. 7.)

Front Cover

Set top control switches in the center position and place finished cover over amplifier chassis.

Line up corner mounting holes with the holes in extension bracket and fasten in place with screws provided. (Fig. 8.) Then place knobs on switch arms and on control shafts.

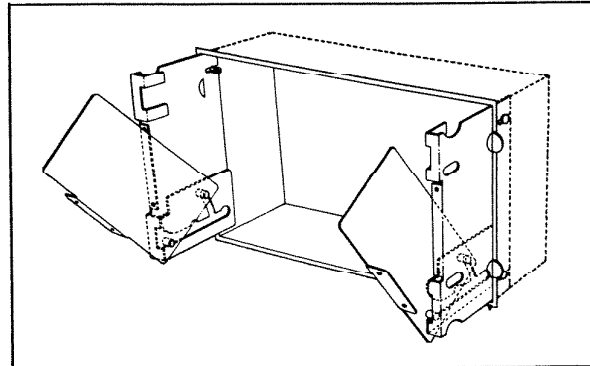

Fig. 3. Mounting Mechanism and Tilt-Out Feature.

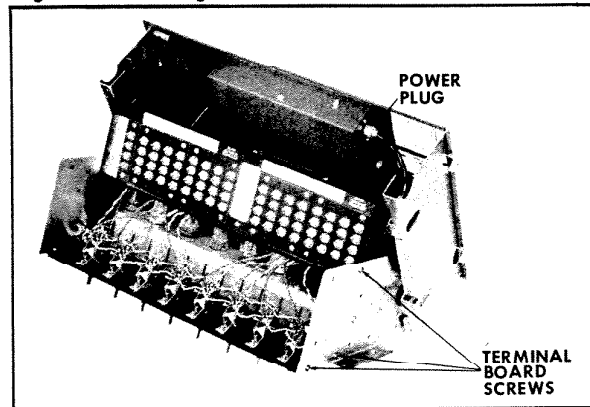

Fig. 4. Terminal Board Screws and Power Plug.

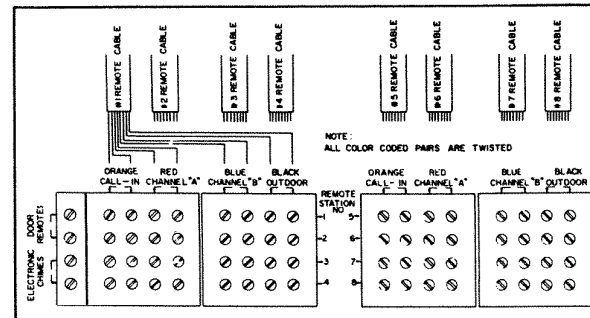

Fig. 5. Remote Speaker Cable Connections.

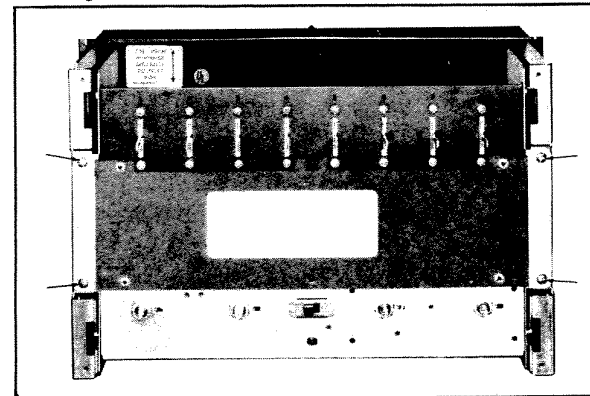

Fig. 6. Secure Chassis to Rough-in Box.

INSTALLATION INSTRUCTIONS (Cont'd)

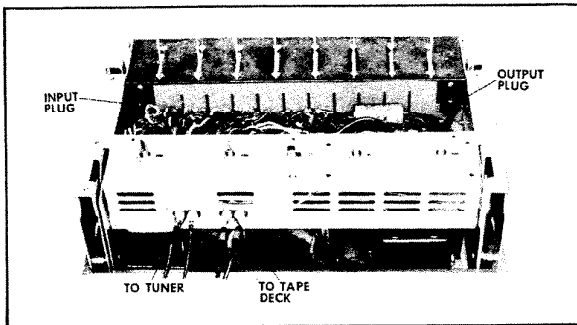

Fig. 7. Signal Lead Connections.

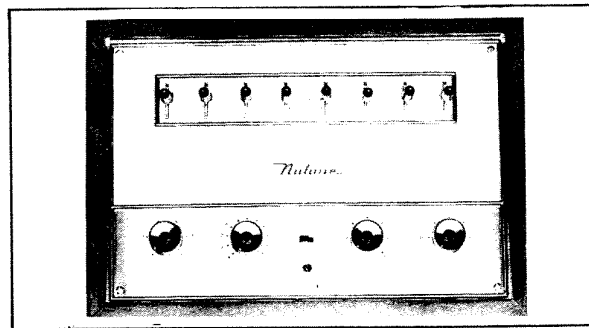

Fig. 8. Finished Cover and Panel Assembly.

MODEL 2402 TUNER

Mounting Tuner Chassis

CAUTION: When lifting chassis, be careful not to lift by the dial glass or dial string.

Position the studs on side of chassis into slots provided on extension brackets and push chassis into the box.

Tilt-Out Feature -- This feature allows both hands to be free, for wiring and preliminary servicing procedures. Pull set outward until the studs on the chassis stop against the front edge of the mounting slot in the extension bracket.

Tilt the unit outward. The back mounting stud fits into the diagonal slot in the extension bracket, and holds the chassis at an angle. (Fig. 9.)

Connecting Antenna and Signal Leads

Tilt chassis outward to expose the antenna terminal strips.

AM Antenna - Connect the blue antenna wire to the antenna screw at left of chassis. (Fig. 9.)

FM Antenna - If the FM antenna furnished with the unit is used, connect lead to either of the end terminals of the FM antenna terminal strip.

If coax cable is used, connect the center wire of the cable to either end terminal of the terminal strip, and the braided shield to the center terminal.

If an FM antenna is used, connect the twinlead to both end terminals on the terminal strip.

Plug in power cord to receptacle in junction box. (Fig. 9.)

Push chassis back into the rough-in box. Fasten in place with screws through mounting tabs on the side of the chassis. (Fig. 10.)

The signal leads plug into jacks on the underside of the chassis. Each set of jacks is for a particular unit of the system.

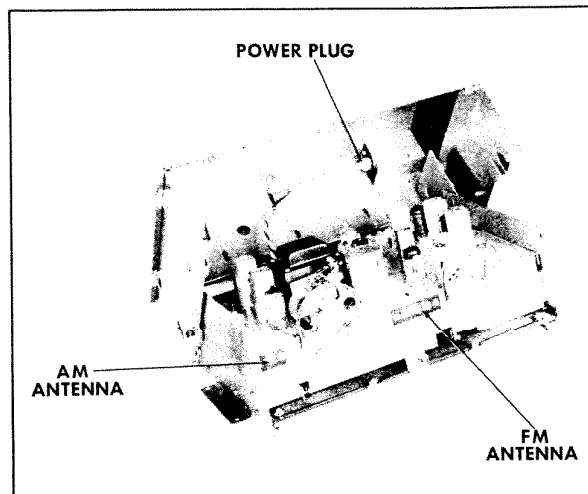

Fig. 9. Power and Antenna Connections.

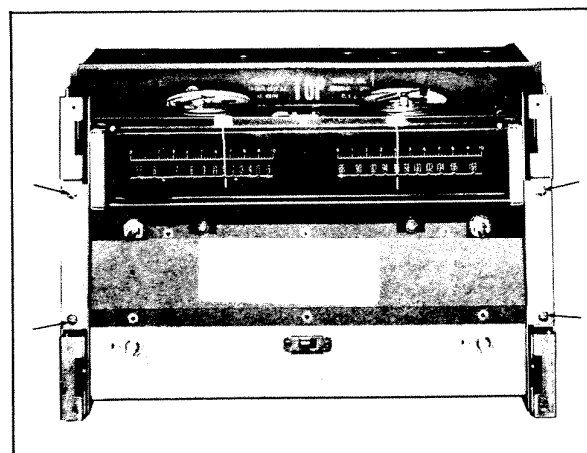

Fig. 10. Secure Chassis to Rough-in Box.

INSTALLATION INSTRUCTIONS (Cont'd)

Each set of leads is tagged and the jacks are marked to insure the proper connection between the units. (Fig. 11.)

Insert leads from left to right as follows:

Channel A and B from amplifier.
Channel A and B from phonograph.
Channel A and B from tape deck.

Make sure the leads are pushed firmly into the jacks.

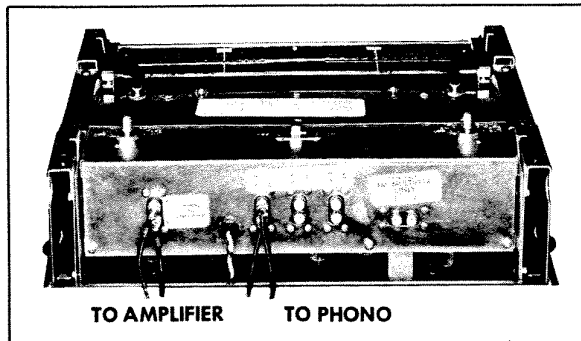

Fig. 11. Signal Lead Connections.

Front Cover

Place finished cover and panel assembly over tuner chassis. Line up corner mounting holes with holes in extension brackets and fasten in place with screws provided. (Fig. 12.)

Place knobs on control and switch shafts.

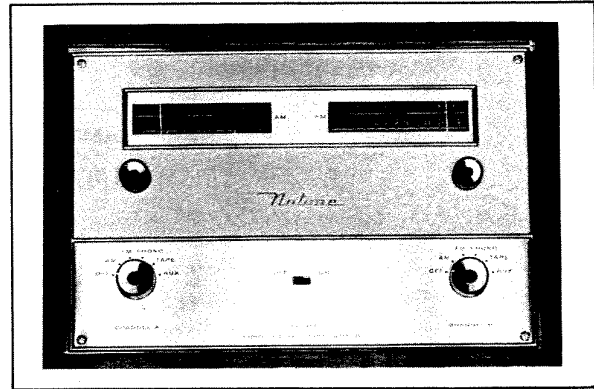

Fig. 12. Finished Cover and Panel Assembly.

INSIDE SPEAKER (WITH CONTROLS)

The speaker with controls mounts to the speaker frame. Two slots are provided in the back edge of the speaker guard plate. Position these slots over studs on the speaker frame and lock in place by pushing speaker assembly to the left. This allows the speaker to hang at an angle for easy access to the terminal board to connect speaker wires. (Fig. 13.)

The speaker is color coded the same as the amplifier for proper placement of wires. Connect wires to the terminal strip according to color code (red to red, black to black, etc.). (Fig. 14.)

NOTE: The two gray terminals are for the inter connecting wires to the speaker without controls. Connect the two-conductor cable to these terminals.

Remove the speaker guard plate from studs on frame and mount speaker into position with screws provided. (Fig. 15.)

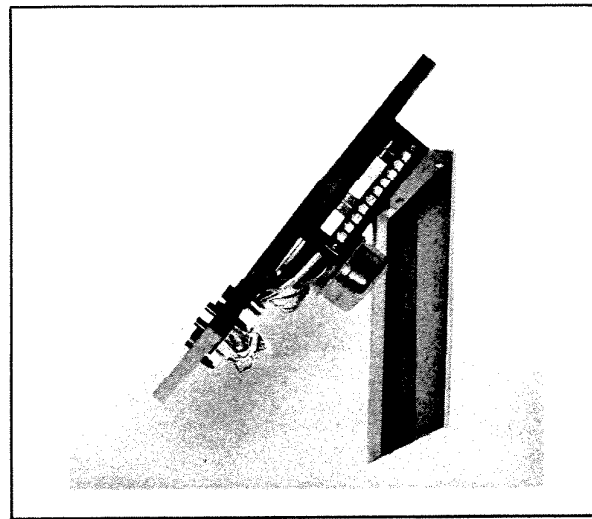

Fig. 13. Mounting Speaker (With Controls).

INSTALLATION INSTRUCTIONS (Cont'd)

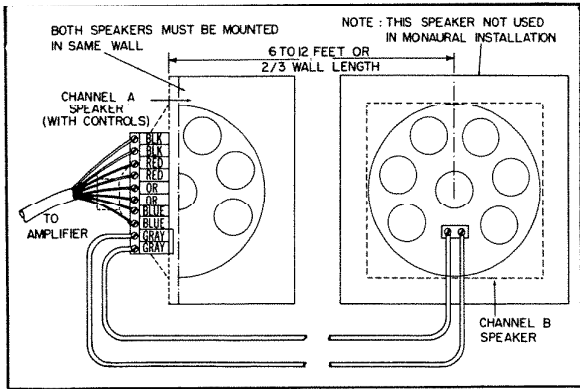

Fig. 14. Cable Connections for Speaker Assembly.

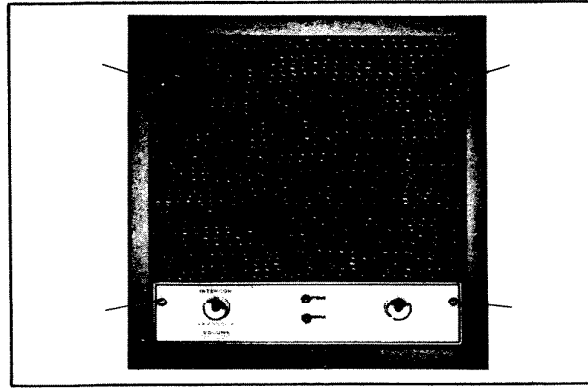

Fig. 15. Finished Cover and Panel Assembly.

INSIDE SPEAKER (WITHOUT CONTROLS)

Hook speaker guard plate to mounting frame and connect two wires from speaker with controls to the mounting strip. Mount speaker with screws provided. (Fig. 16.)

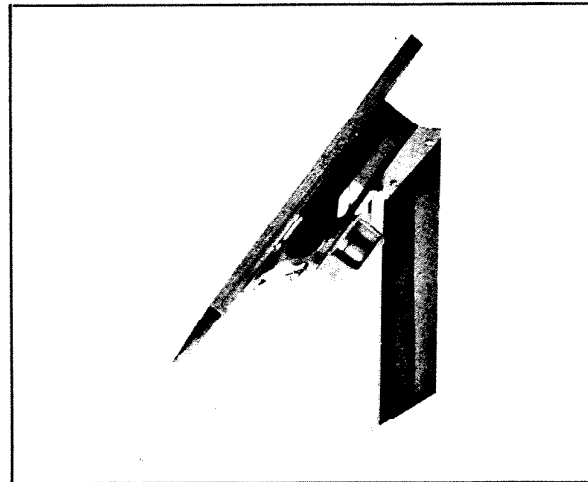

Fig. 16. Mounting Speaker (Without Controls).

DOOR SPEAKER

Connect two wires to the two screws on terminal strip of speaker. Fasten speaker into box with screws provided (Fig. 17.)

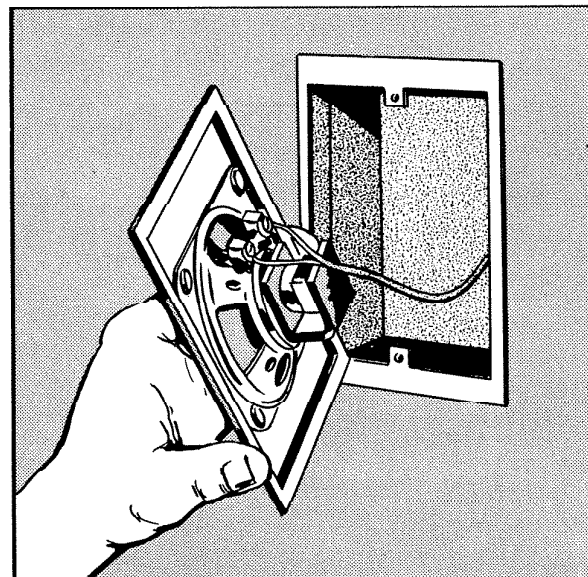

Fig. 17. Door Speaker Mounting.

INSTALLATION INSTRUCTIONS (Cont'd)
PATIO SPEAKER

Connect two wires from remote control unit to the two screws on speaker terminal strip.

Mount speaker and plate assembly to the rough-in frame with the 12 screws provided. All screws must be used to prevent speaker rattle. (Fig. 18.)

Align the mounting holes of the finished frame with the holes in the rough-in frame and fasten in place with screws provided. (Fig. 19.)

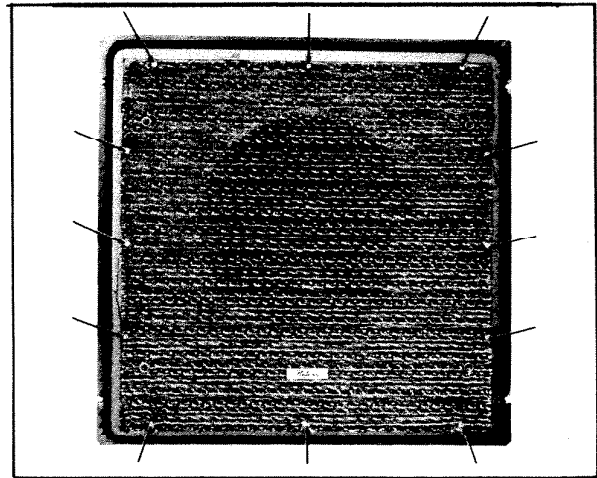

Fig. 18. Plate Assembly of Patio Speaker.

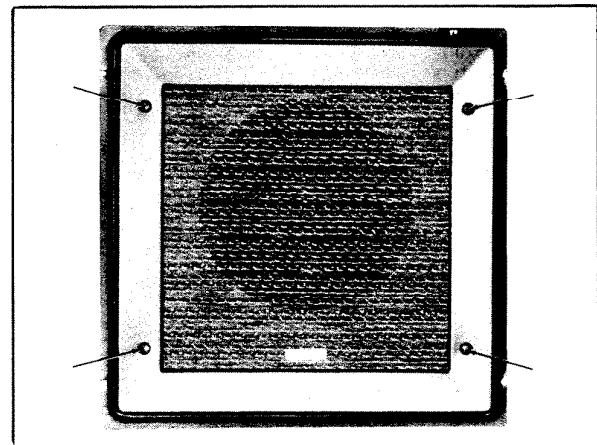
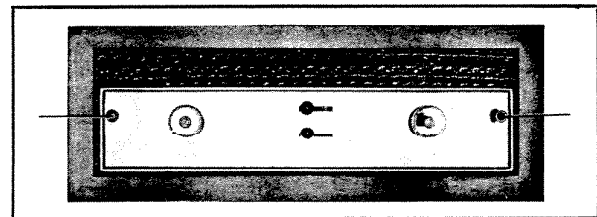

Fig. 19. Finished Frame Assembly of Patio Speaker.

REMOTE CONTROL

The remote control inside and outside units are mounted in the same manner. Connect the 8-conductor cable to the terminal strip according to the color code (red to red, black to black, etc.). The two grey terminals on each side of the strip are for the wiring to the speakers. Connect the grey two-conductor cable to these terminals.

Align the mounting holes of the unit with the holes in the rough-in box and fasten in place with screws provided. (Fig. 20.)



(A) Inside Remote

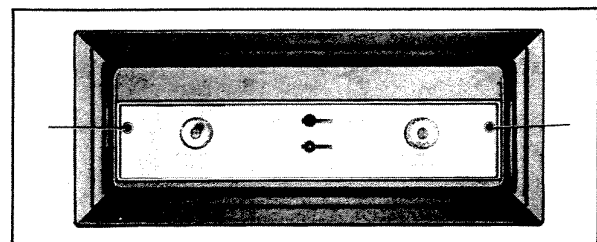

(B) Outside Remote

Fig. 20. Finished Assembly of Remote Control Panels.

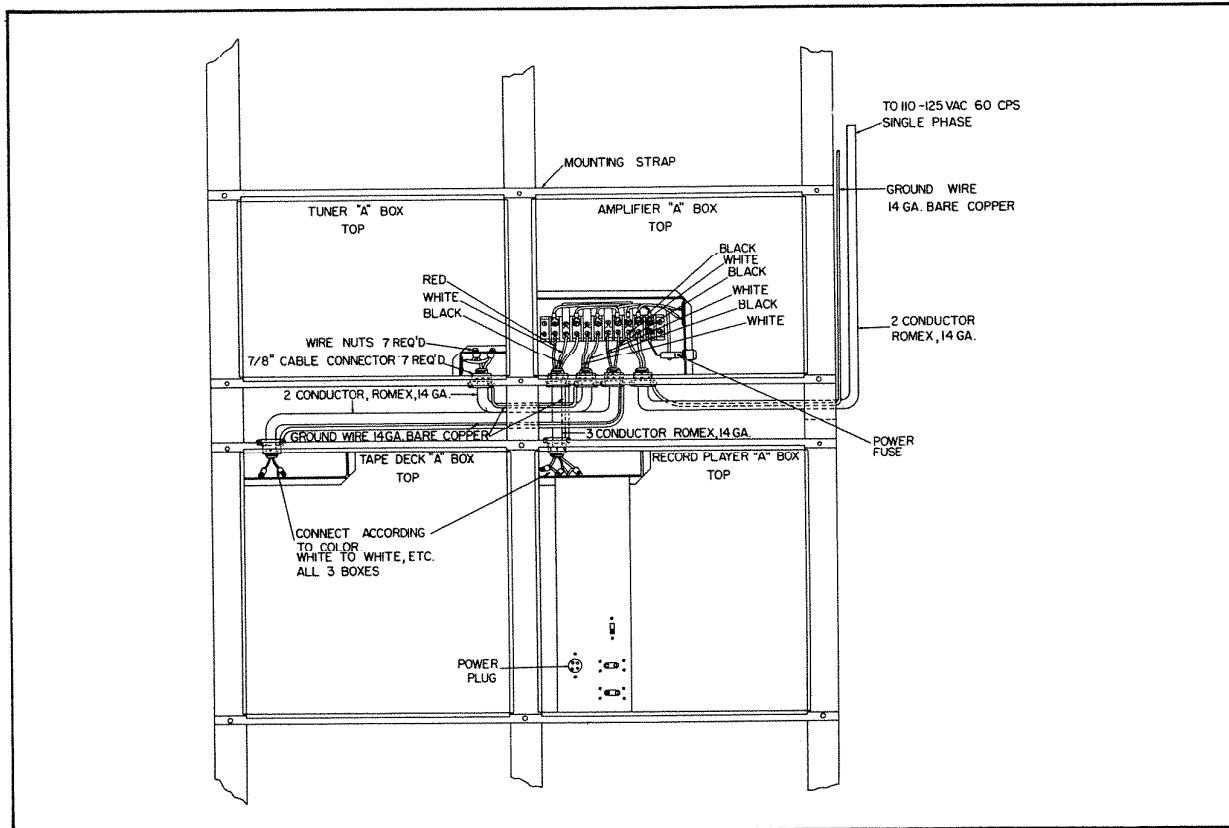

Fig. 21. Power Connections to Rough-In Boxes.

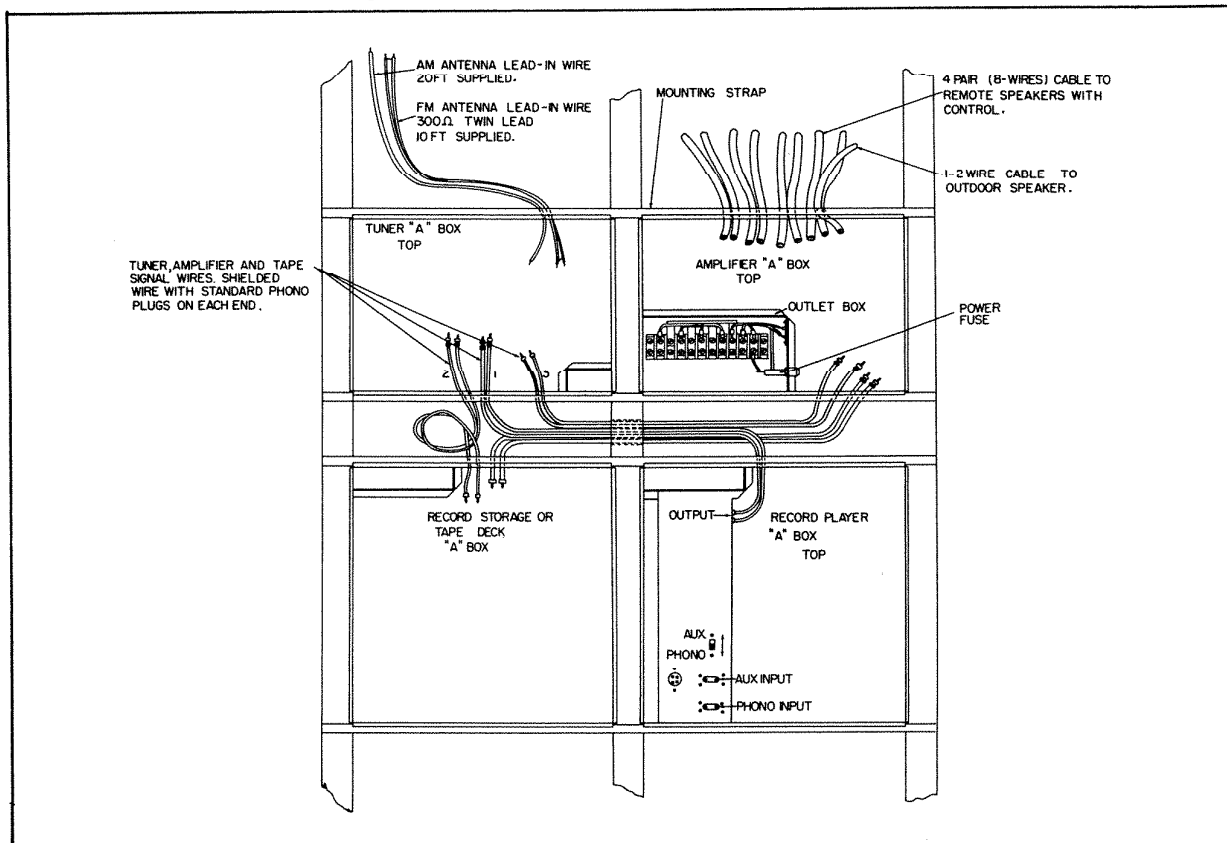

Fig. 22. Signal Lead Connections to Rough-in Boxes.

ALIGNMENT INSTRUCTIONS

Pre-Alignment Instructions

Output of signal generator should be no higher than necessary to obtain an output reading.
Both the AM and FM dial pointers should be at the zero mark on the left end of the log scale when the tuning gangs are fully closed.
Alignment Tools: Standard for hex and slotted type adjustments.

10KC Whistle Filter Alignment							
DUMMY ANTENNA	SIGNAL GENERATOR COUPLING	SIGNAL GENERATOR FREQUENCY	BAND SWITCH POS.	RADIO DIAL SETTING	CONNECT VTVM	ADJUST	REMARKS
1.	High side to pin 1 (grid) of V9. Low side to chassis.	10KC (Unmod)	AM	Tuning gang fully open	AC probe to channel "A" output jack.	A9	Adjust for MINIMUM output.
AM IF and RF Alignment							
DUMMY ANTENNA	SIGNAL GENERATOR COUPLING	SIGNAL GENERATOR FREQUENCY	BAND SWITCH POS.	RADIO DIAL SETTING	CONNECT VTVM	ADJUST	REMARKS
2.	50mmf High side to pin 1 (grid) of V8. Low side to chassis.	455KC (400% Mod)	AM	Tuning gang fully open	AC probe to channel "A" output jack.	A1, A2	Adjust for maximum output.
3.	" High side to pin 1 (Mixer Grid) of V7. Low side to chassis.	"	"	"	"	A3, A4	"
4.	" Antenna	1400KC (400% Mod)	"	14	"	A6	Adjust for maximum output while rocking tuning gang.
5.	"	"	"	14	"	A8	Adjust for maximum output.
6.	"	600KC (400% Mod)	"	6	"	A5	"
7.	"	"	"	6	"	A7	Adjust for maximum output. Repeat steps 4, 5, 6 and 7 until correct dial calibration and circuit tracking are accomplished.
FM IF Alignment Using AM Signal Generator and VTVM							
DUMMY ANTENNA	SIGNAL GENERATOR COUPLING	SIGNAL GENERATOR FREQUENCY	BAND SWITCH POS.	RADIO DIAL SETTING	CONNECT VTVM	ADJUST	REMARKS
1.	50mmf High side to pin 1 (grid) of V4. Low side to chassis.	10.7MC (Unmod)	FM	Tuning gang fully open	DC probe to point . Common to chassis.	A10	Adjust for maximum deflection.
2.	" High side to pin 1 (grid) of V3. Low side to chassis.	"	"	"	"	A12, A13	"
3.	" High side to pin 6 (grid) of V2. Low side to chassis.	"	"	"	"	A14, A15	"
4.	" High side to pin 1 (grid) of V4. Low side to chassis.	"	"	"	DC probe to point . Common to chassis.	All	Adjust for zero reading. A positive and negative reading will be obtained on either side of the correct setting.
FM IF Alignment Using FM Signal Generator and Oscilloscope							
Use frequency modulated signal with 60% modulation and 450KC sweep. Use 60% sawtooth voltage in scope for horizontal deflection.							
DUMMY ANTENNA	SIGNAL GENERATOR COUPLING	SIGNAL GENERATOR FREQUENCY	BAND SWITCH POS.	RADIO DIAL SETTING	CONNECT SCOPE	ADJUST	REMARKS
5.	50mmf High side to pin 6 (grid) of V2. Low side to chassis.	10.7MC (450KC Swp)	FM	Tuning gang fully open	Vert. Amp. thru 100K to negative side of C3.	A10, A12 A13, A14 A15	Disconnect lead 7 of K1. Adjust for curve of maximum amplitude and symmetry similar to Fig. 1.
6.	"	"	"	"	Vert. Amp. thru 100K to multiplex output jack.	All	Reconnect lead 7 of K1. Adjust so that 10.7 MC occurs at center of S-curve similar to Fig. 2. SLIGHTLY retouch A10 for maximum amplitude and S-curve symmetry.
FM RF Alignment							
DUMMY ANTENNA	SIGNAL GENERATOR COUPLING	SIGNAL GENERATOR FREQUENCY	BAND SWITCH POS.	RADIO DIAL SETTING	CONNECT VTVM	ADJUST	REMARKS
7.	Two 120Ω Carbon Resistors Across FM antenna terminals with 120Ω in each lead.	106MC	FM	106MC	AC probe to channel "A" output jack.	A16, A17	Adjust for maximum output.
8.	"	90MC	"	90MC	"	A18, A19	Adjust for maximum output. Repeat steps 7 and 8 until proper dial calibration and circuit tracking are accomplished.

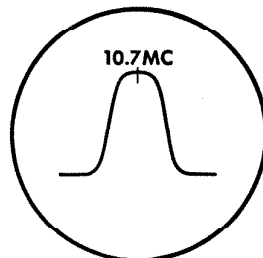

FIG. 1

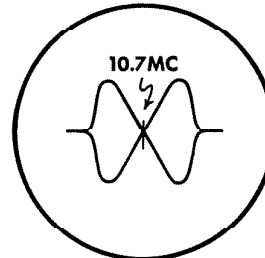

FIG. 2

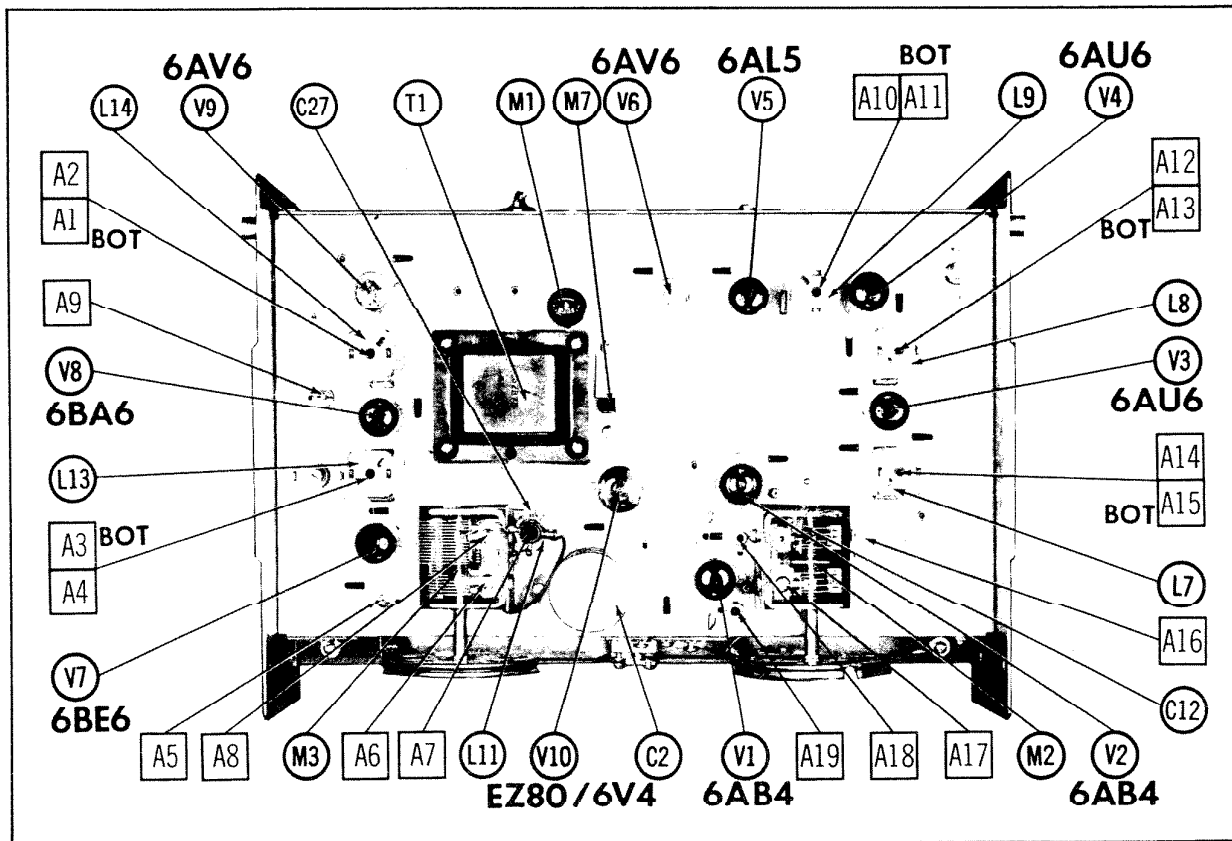

Fig. 23. AM-FM Tuner - Top View.

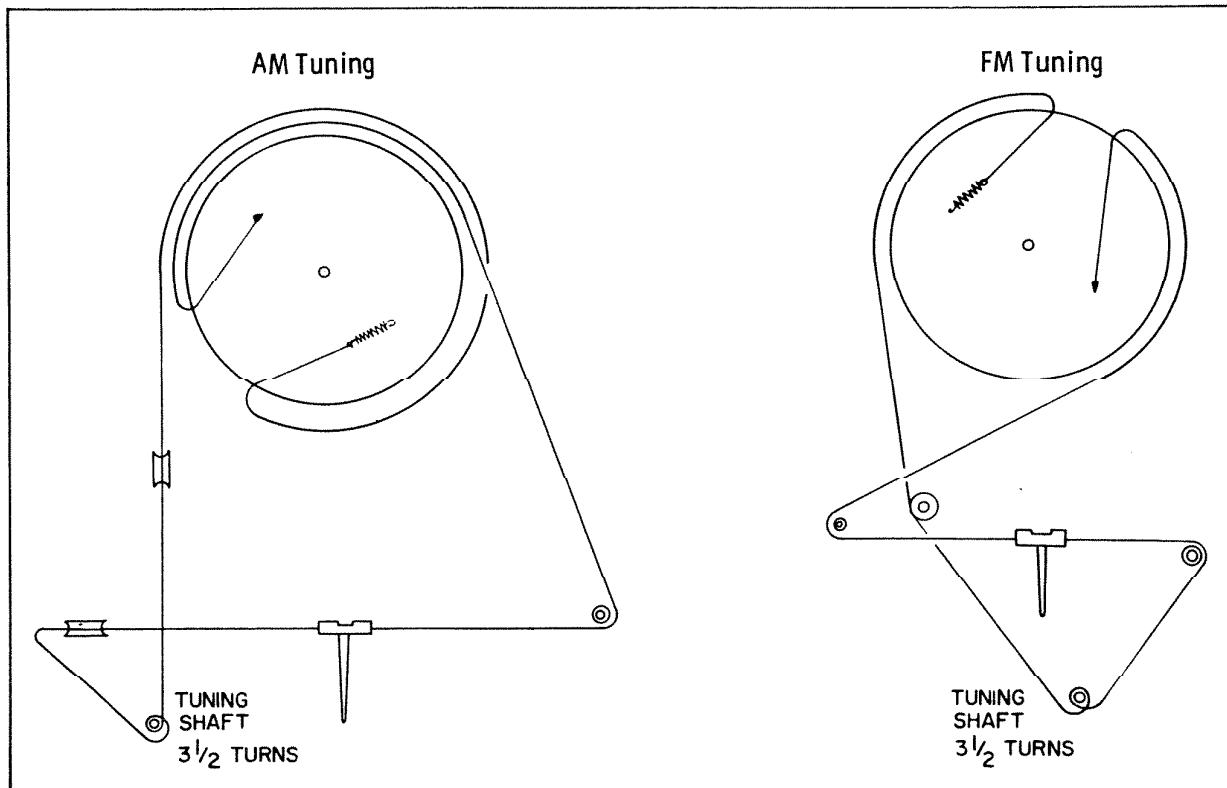

Fig. 24. Dial Cord String Guides.

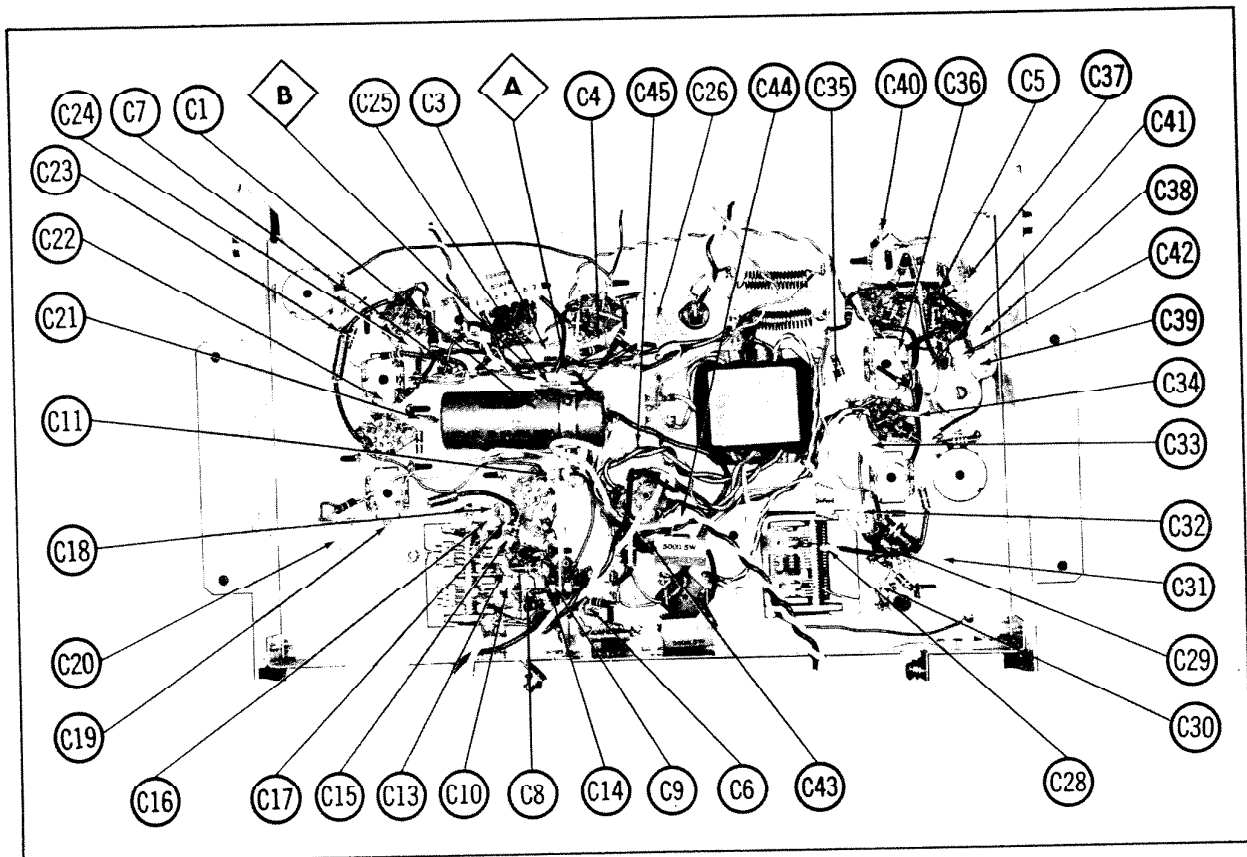

Fig. 25. AM-FM Tuner - Bottom View, Capacitor Identification.

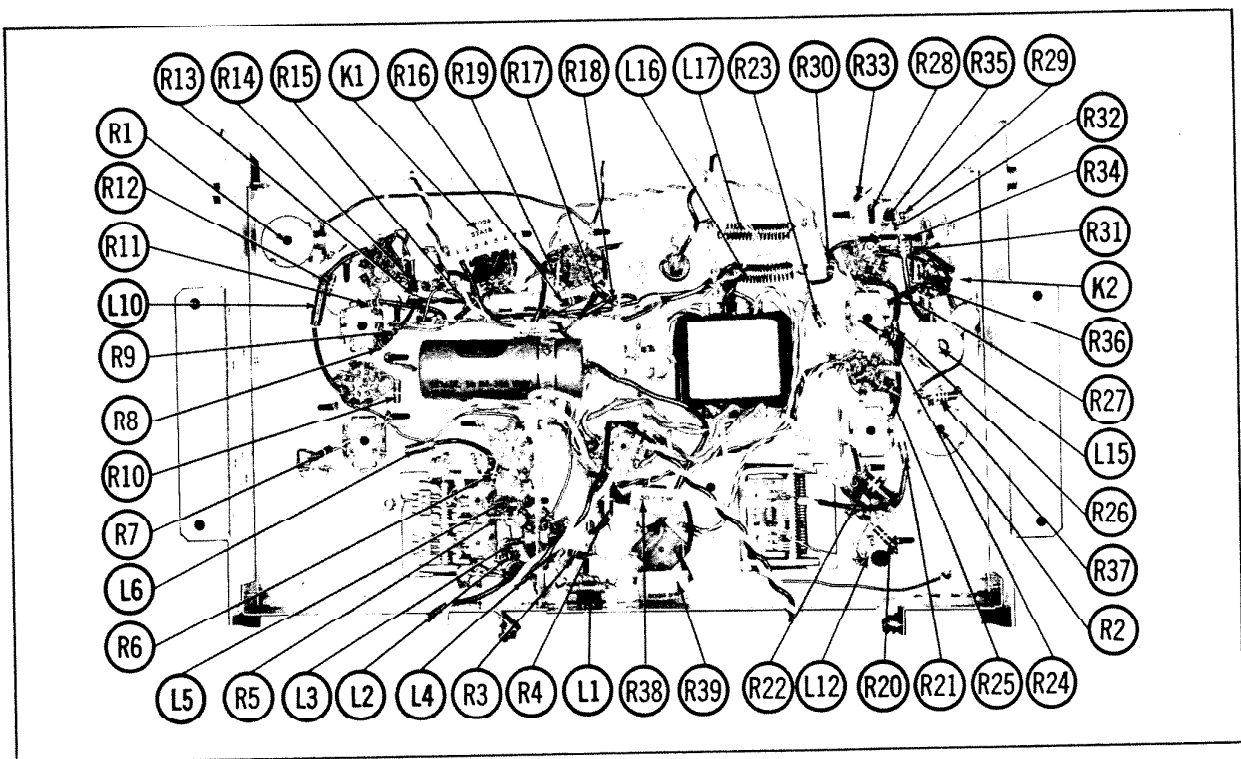

Fig. 26. AM-FM Tuner - Bottom View, Resistor Identification.

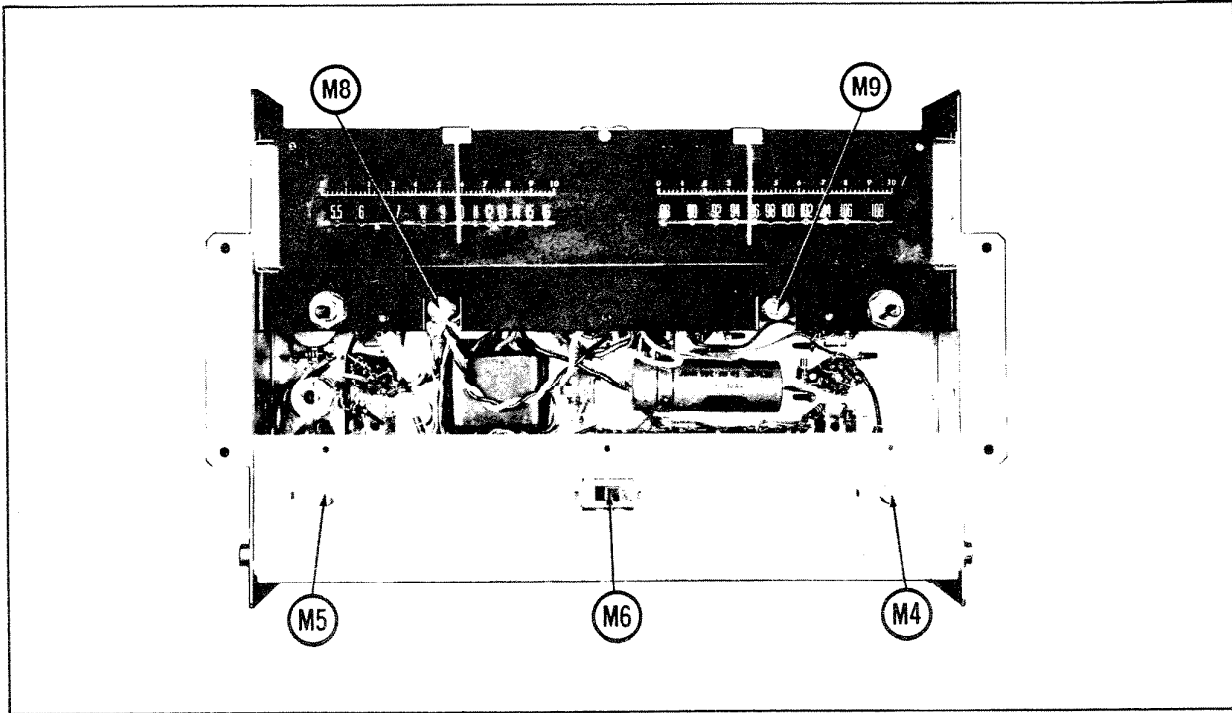

Fig. 27. AM-FM Tuner - Front View.

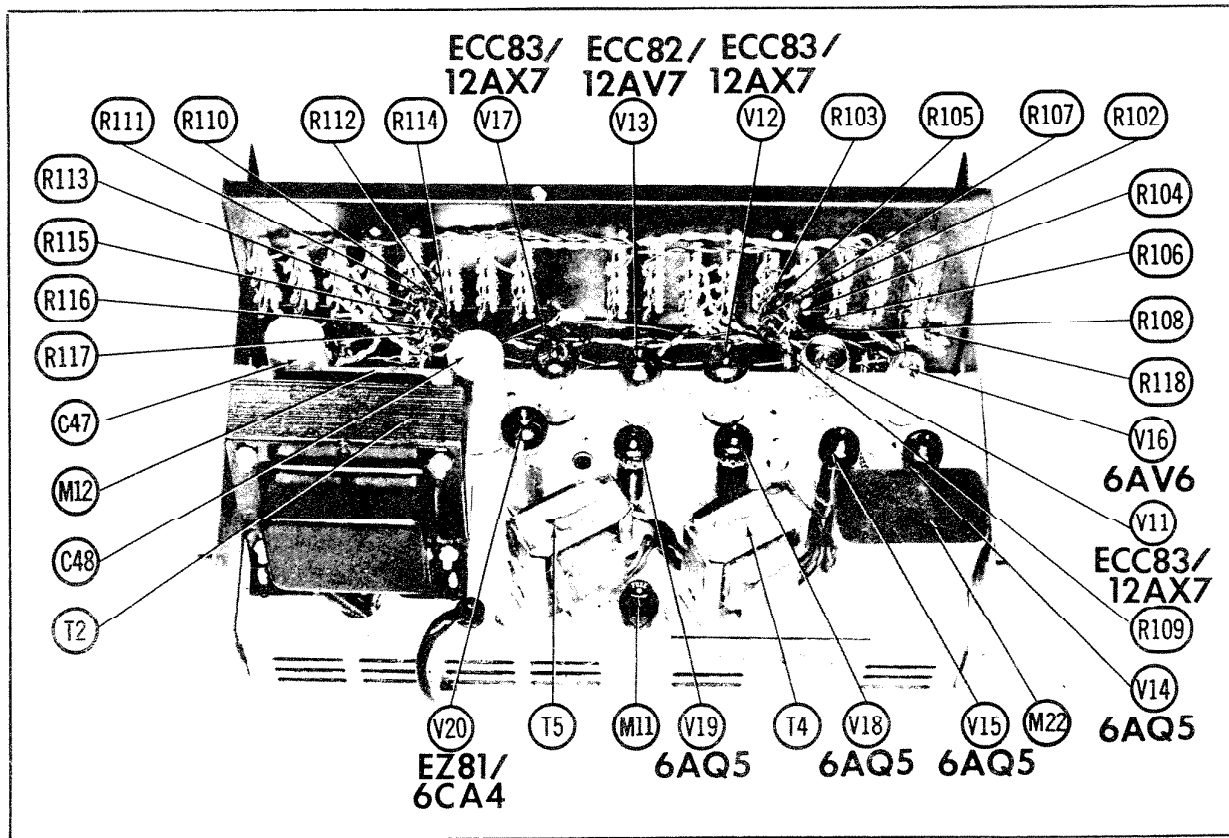

Fig. 28. Amplifier Chassis - Top View.

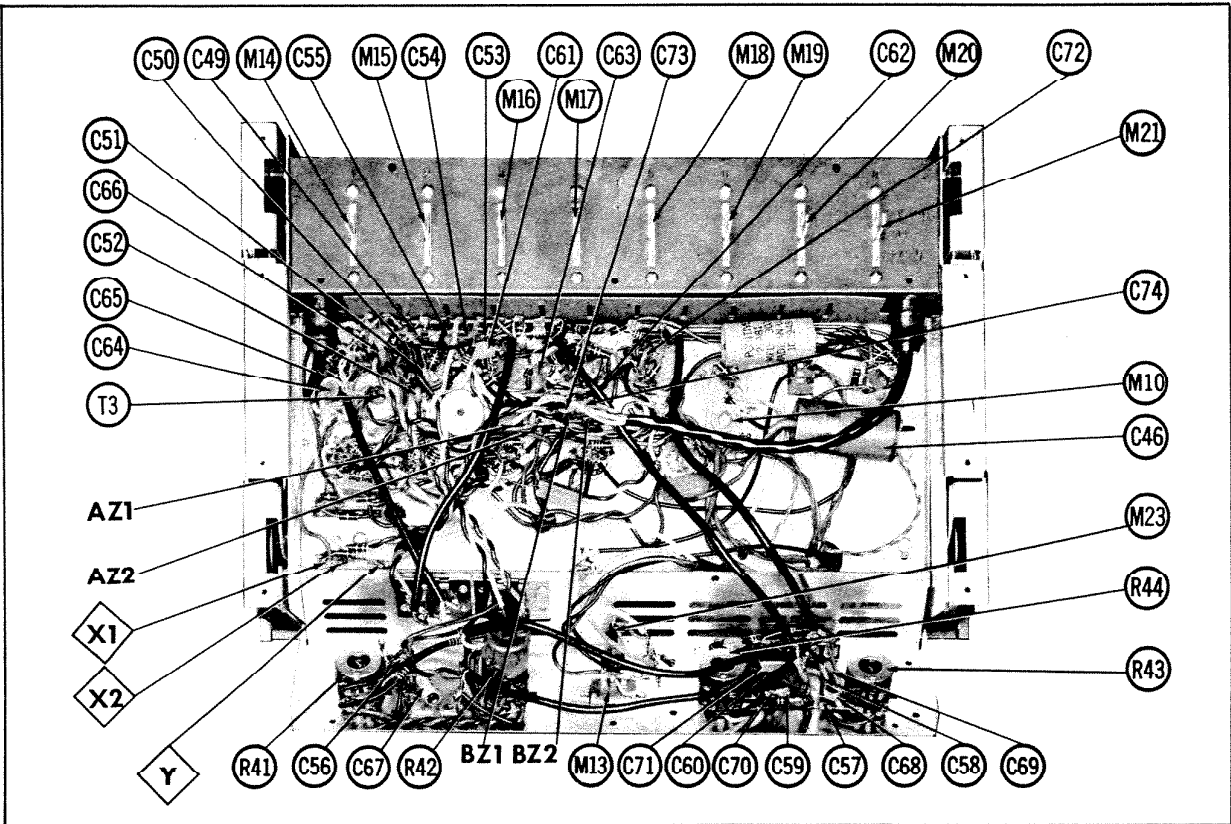

Fig. 29. Amplifier Chassis - Bottom View, Capacitor Identification.

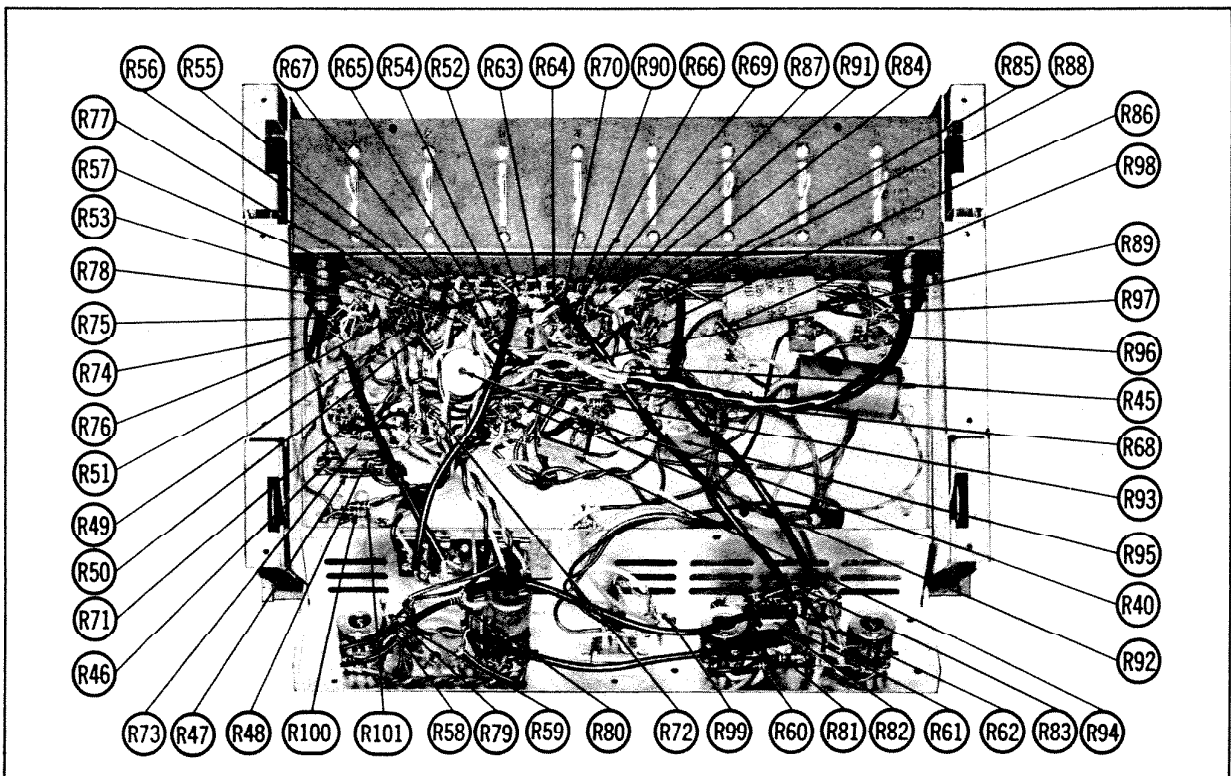

Fig. 30. Amplifier Chassis - Bottom View, Resistor Identification.

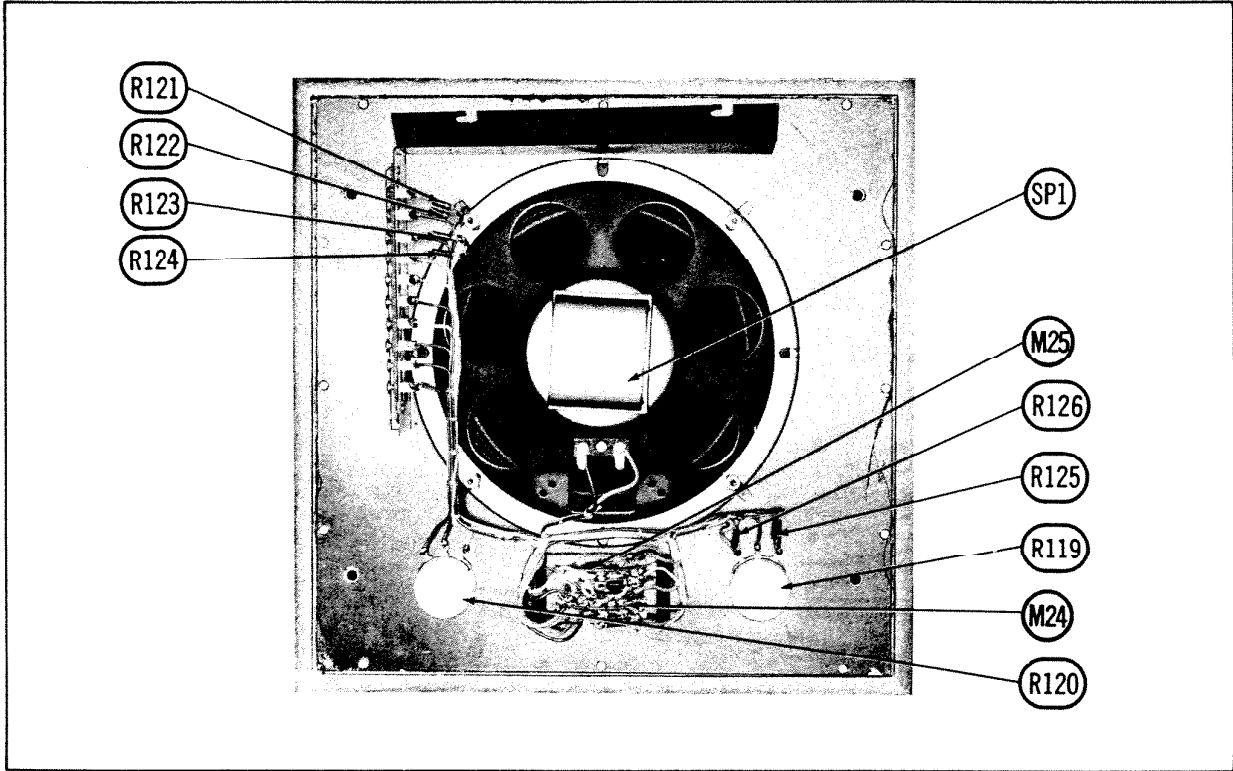

Fig. 31. Speaker With Controls - Component Identification.

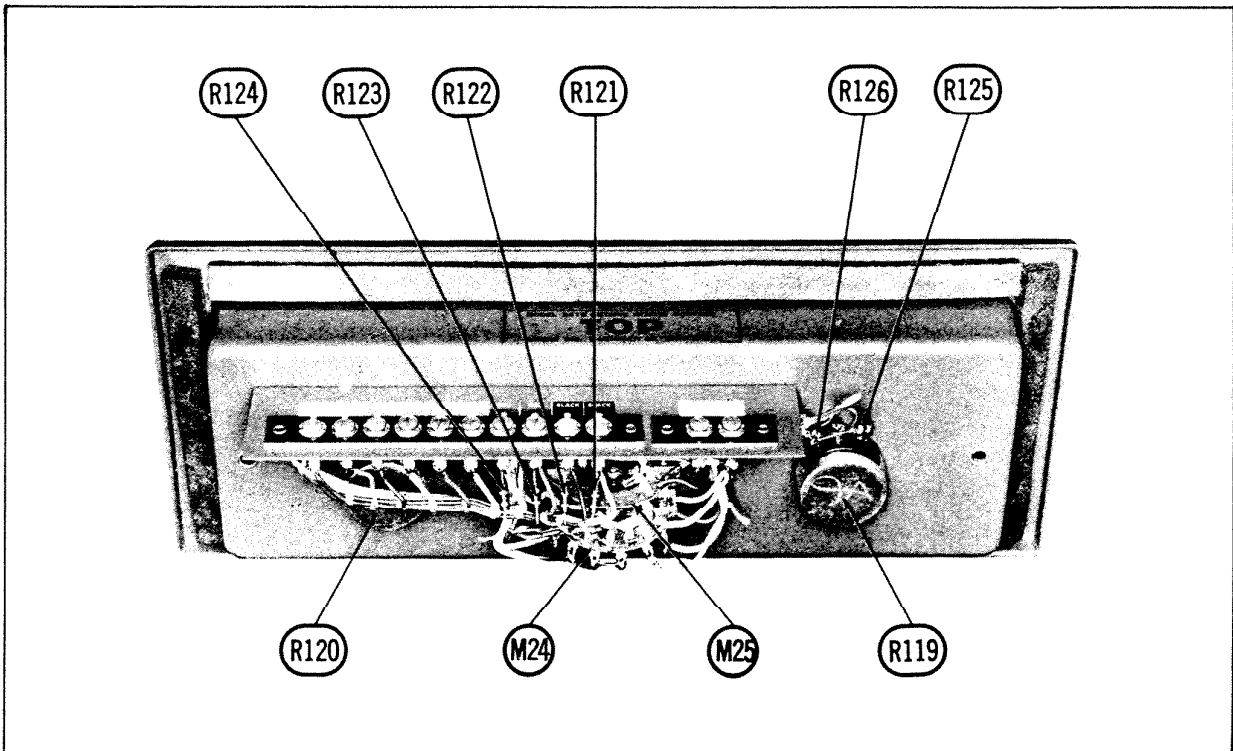
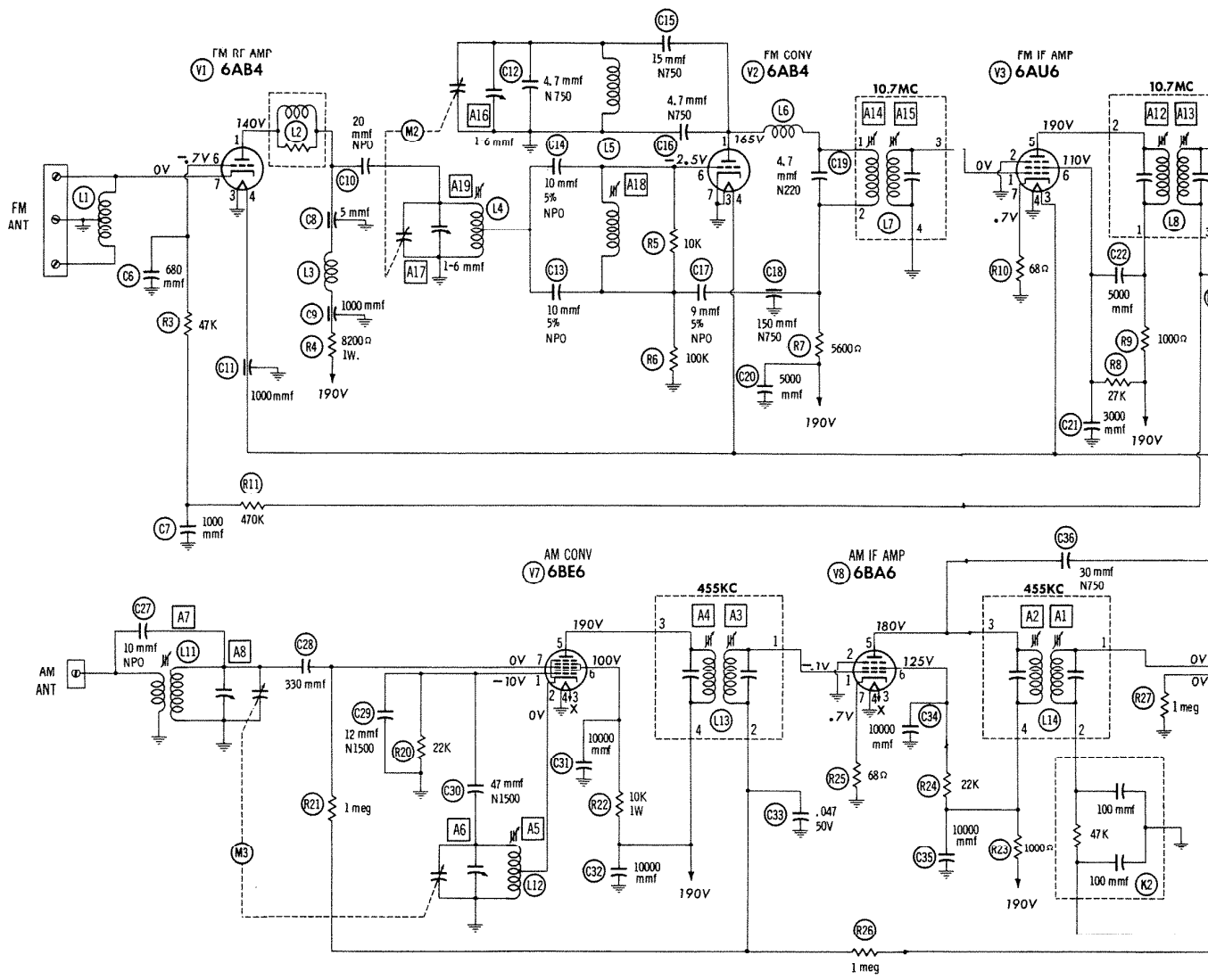

Fig. 32. Remote Control Panel - Component Identification.



1. DC voltage measurements taken with vacuum tube voltmeter; AC voltages measured at 1000 ohms per volt.
2. Socket connections are shown as bottom views.
3. Measured values are from socket pin in common negative.
4. Line voltage maintained at 117 volts for voltage readings.
5. Nominal tolerance on component values makes possible a variation of +15% in voltage and resistance readings.

RESISTANCE READINGS

ITEM	TUBE	Pin 1	Pin 2	Pin 3	Pin 4	Pin 5	Pin 6	Pin 7	Pin 8	Pin 9
V1	6AB4	9200Ω	0Ω	0Ω	0Ω	0Ω	900K	0Ω		
V2	6AB4	*6600Ω	0Ω	0Ω	0Ω	0Ω	110K	0Ω		
V3	6AU6	0Ω	0Ω	0Ω	0Ω	*2K	*28K	68Ω		
V4	6AU6	100K	0Ω	0Ω	0Ω	*30K	*30K	0Ω		
V5	6AL5	8300Ω	7800Ω	0Ω	0Ω	INF	0Ω	INF		
V6	6AV6	1.7meg	1800Ω	0Ω	0Ω	0Ω	0Ω	*100K		
V7	6BE6	22K	0Ω	0Ω	0Ω	*100Ω	*11K	3meg		
V8	6BA6	2meg	0Ω	0Ω	0Ω	*2000Ω	*23K	68Ω		
V9	6AV6	1.5meg	3300Ω	0Ω	0Ω	1meg	300K	*100K		
V10	EZ80 6V4	125Ω	NC	3meg	0Ω	0Ω	0Ω	125Ω		

* MEASURED FROM PIN 3 OF V10.

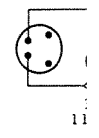
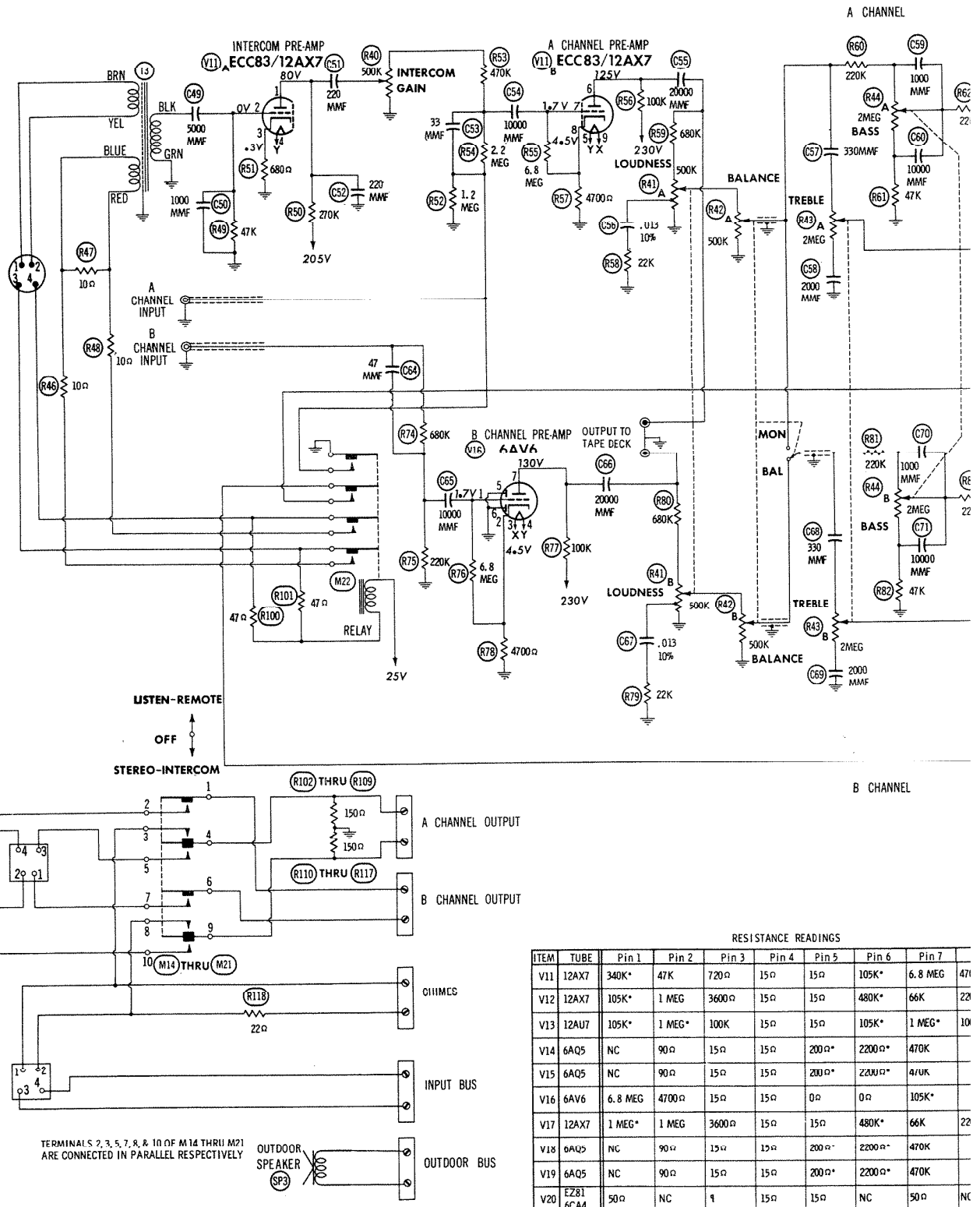

Fig. 33. AM-FM Tuner Sc



RESISTANCE READINGS

ITEM	TUBE	Pin 1	Pin 2	Pin 3	Pin 4	Pin 5	Pin 6	Pin 7
V11	12AX7	340K*	47K	720Ω	15Ω	15Ω	105K*	6.8 MEG
V12	12AX7	105K*	1 MEG	3600Ω	15Ω	15Ω	480K*	66K
V13	12AU7	105K*	1 MEG*	100K	15Ω	15Ω	105K*	1 MEG*
V14	6AQ5	NC	90Ω	15Ω	15Ω	200Ω*	2200Ω*	470K
V15	6AQ5	NC	90Ω	15Ω	15Ω	200Ω*	2200Ω*	470K
V16	6AV6	6.8 MEG	4700Ω	15Ω	15Ω	0Ω	0Ω	105K*
V17	12AX7	1 MEG*	1 MEG	3600Ω	15Ω	15Ω	480K*	66K
V18	6AQ5	NC	90Ω	15Ω	15Ω	200Ω*	2200Ω*	470K
V19	6AQ5	NC	90Ω	15Ω	15Ω	200Ω*	2200Ω*	470K
V20	EZ81 6CA4	50Ω	NC	9	15Ω	15Ω	NC	50Ω

*Measured from Pin #3 of V20
†This reading will vary depending on condition of associated electrolytic.

Fig. 34. Amplifier Schemat

A CHANNEL

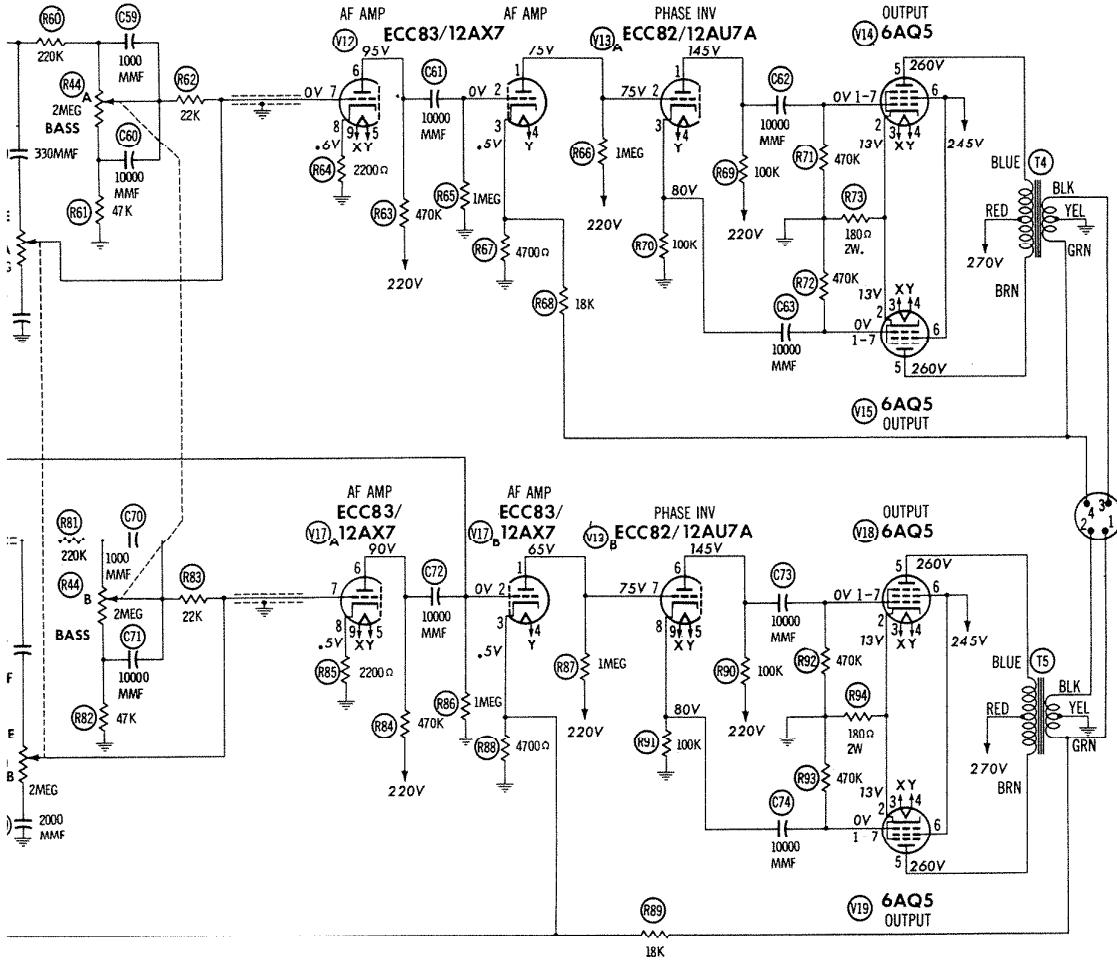

B CHANNEL

NGS

n 5	Pin 6	Pin 7	Pin 8	Pin 9
1	105K*	6.8 MEG	4700Ω	15Ω
1	480K*	66K	2200Ω	15Ω
1	105K*	1 MEG*	100K	15Ω
Ω*	2200Ω*	470K		
Ω*	2200Ω*	470K		
	0Ω	105K*		
1	480K*	66K	2200Ω	15Ω
Ω*	2200Ω*	470K		
Ω*	2200Ω*	470K		
	NC	50Ω	NC	TP

d electrolytic.

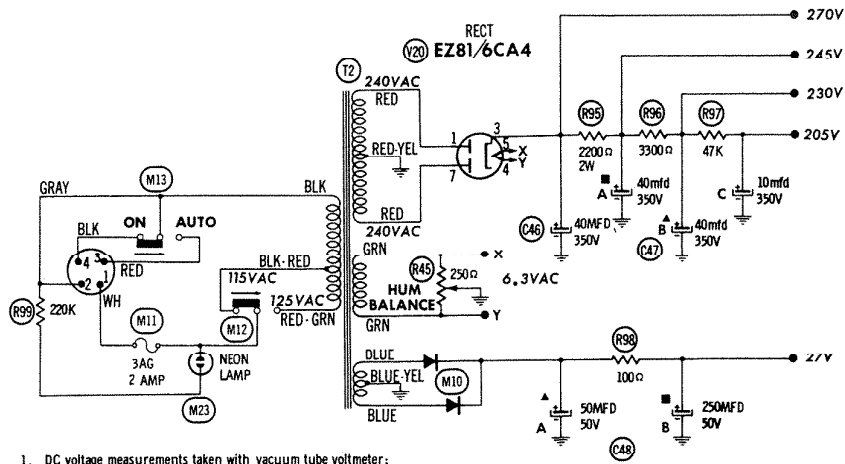

1. DC voltage measurements taken with vacuum tube voltmeter; AC voltages measured at 1000 ohms per volt.
2. Socket connections are shown as bottom views.
3. Measured values are from socket pin to common negative.
4. Line voltage maintained at 117 volts for voltage readings.
5. Nominal tolerance of component values makes possible a variation of ± 1% in voltage and resistance readings.
6. All controls at minimum, proper output load connected.

mplifier Schematic.

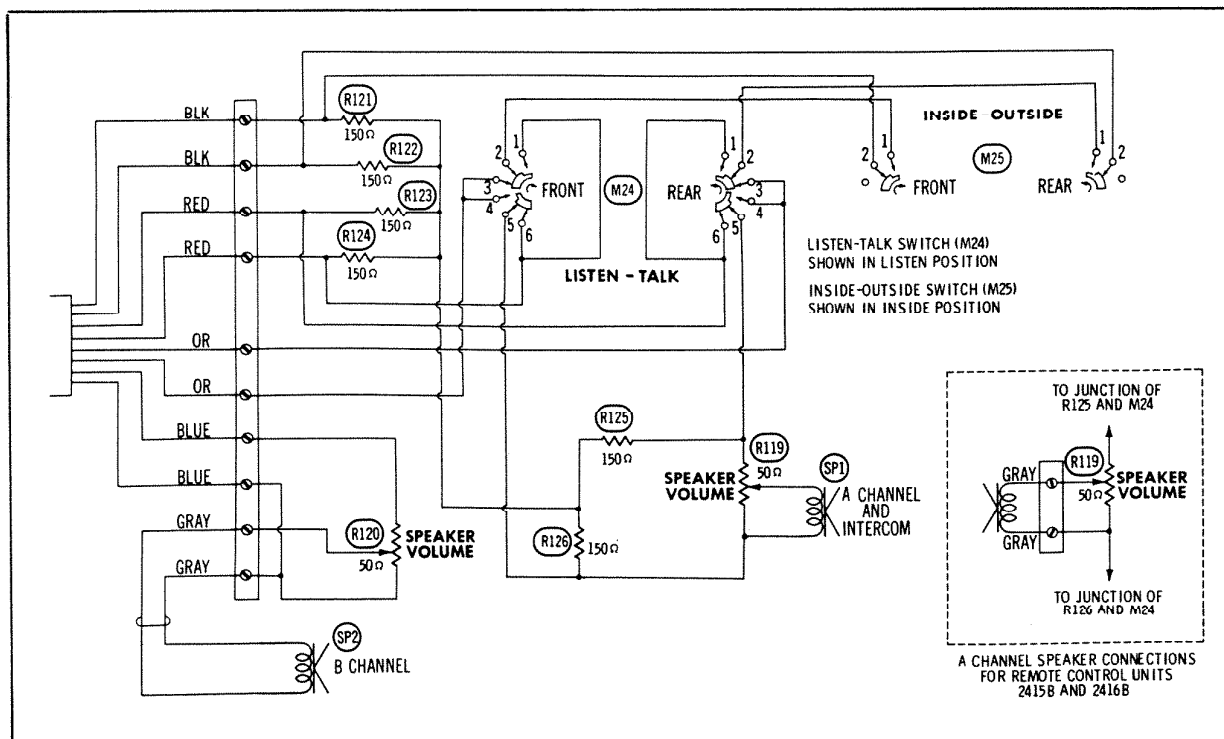

Fig. 35. Speaker Assembly With Controls and Remote Control Panel Schematic.

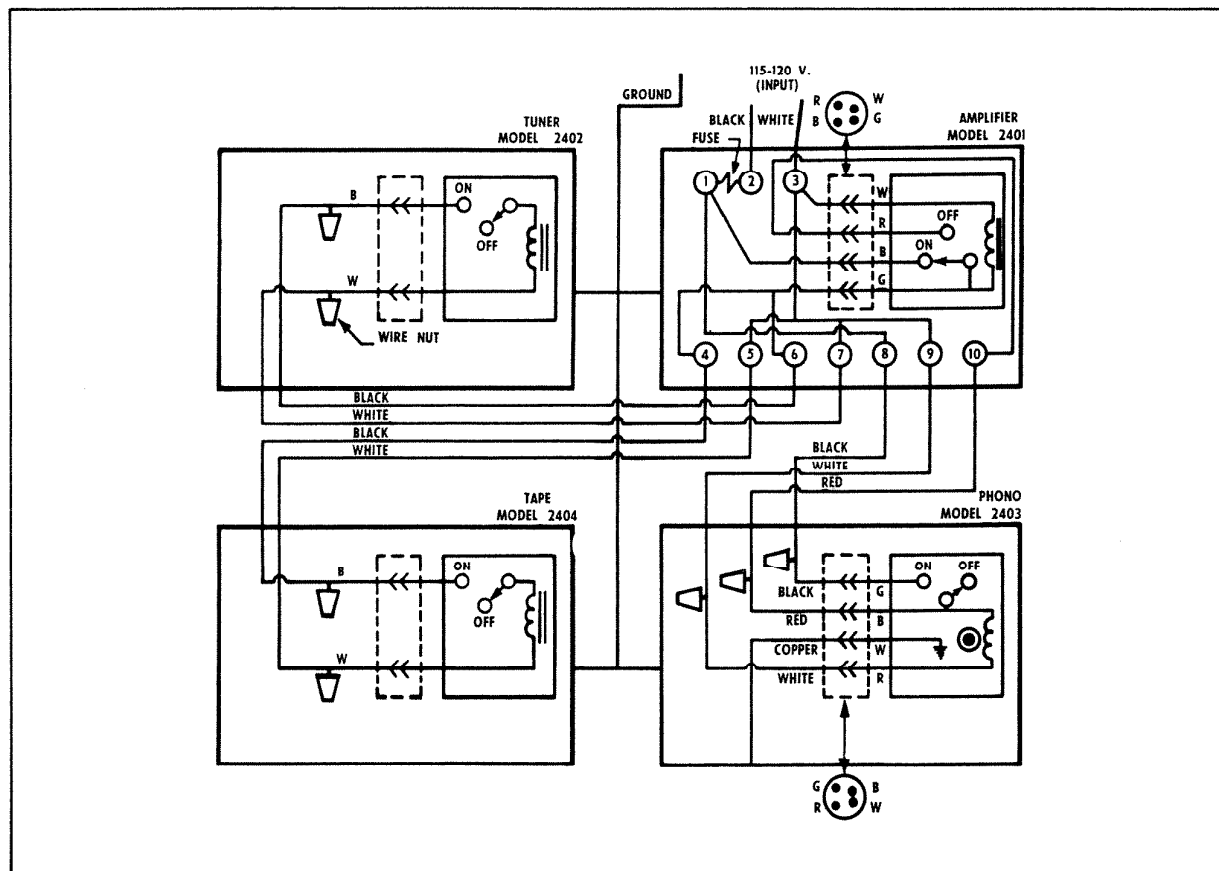

Fig. 36. Power Wiring for Models 2401, 2402, 2403, & 2404.

TUNER PARTS LIST

Ref. No.	Part No.	Description
----------	----------	-------------

TUBES

V1	6AB4	FM RF Amplifier
V2	6AB4	FM Converter
V3	6AU6	FM IF Amplifier
V4	6AU6	Limiter
V5	6AL5	Ratio Detector
V6	6AV6	AF Amplifier
V7	6BE6	AM Converter
V8	6BA6	AM IF Amplifier
V9	6AV6	Det-AVC-AF Amp
V10	EZ80/6V4	Rectifier

CAPACITORS

C1	B35010	50 mfd @ 300V, Elect.
C2A	B35009	40 mfd @ 300V, Elect.
C2B		40 mfd @ 300V, Elect.
C3	A35011	10 mfd @ 50V, Elect.
C4	B35012	20 mfd @ 6V, Elect.
C5	B35012	20 mfd @ 6V, Elect.
C6		680 mmf, ± 10%, Ceramic Disc.
C7		1000 mmf, ± 20%, Ceramic Disc.
C8		5 mmf, ± 20%, Feed Thru
C9		1000 mmf, Feed Thru
C10		20 mmf, ± 10% NPO, Ceramic Disc.
C11		1000 mmf, Feed Thru
C12		4.7 mmf, ± 10% N750, Ceramic Disc.
C13		10 mmf, ± 5% NPO, Ceramic Disc.
C14		10 mmf, ± 5% NPO, Ceramic Disc.
C15		15 mmf, ± 10% N750, Ceramic Disc.
C16		4.7 mmf, ± 10% N750, Ceramic Disc.
C17		9 mmf, ± 5% NPO, Ceramic Disc.
C18		150 mmf, ± 10% N750, Ceramic Disc.
C19		4.7 mmf, ± 10% N220, Ceramic Disc.
C20		5000 mmf, +80% -20%, Ceramic Disc.
C21		3000 mmf @ 1000V, ± 10% Ceramic Disc.
C22		5000 mmf, +80% -20%, Ceramic Disc.
C23		47 mmf, ± 10%, N1500 Ceramic Disc.
C24		5000 mmf, +80% -20%, Ceramic Disc.
C25		20000 mmf, +80% -20%, Ceramic Disc.
C27		.05 mfd @ 400V, ± 20%, Tubular
C28		10 mmf, ± 10% NPO, Ceramic Disc.
C29		330 mmf, ± 10%, Ceramic Disc.
C30		12 mmf, ± 10%, N1500, Ceramic Disc.
C31		47 mmf, ± 10%, N1500, Ceramic Disc.
C32		10000 mmf, +80% -20%, Ceramic Disc.
C33		10000 mmf, +80% -20%, Ceramic Disc.
C34		.047 mfd @ 50V, ± 20%, Tubular
C35		10000 mmf, +80% -20%, Ceramic Disc.
C36		1000 mmf, +80% -20%, Ceramic Disc.
C37		30 mmf, ± 10%, N750, Ceramic Disc.
C38		20000 mmf, +80% -20%, Ceramic Disc.
C39		.05 mfd @ 400V, ± 20%, Tubular
C40		10000 mmf, +80% -20%, Ceramic Disc.
C41		680 mmf, ± 10%, Ceramic Disc.
C42		.0047 mfd @ 200V, ± 5%, Tubular
C43		.0047 mfd @ 200V, ± 5%, Tubular
C44		1000 mmf @ 1000V, Ceramic Disc.
C45		1000 mmf @ 1000V, Ceramic Disc.

Ref. No.	Part No.	Description
----------	----------	-------------

RESISTORS

R1	B34009	250K, 1/2 Watt, FM Level Pot.
R2	B34009	250K, 1/2 Watt, AM Level Pot.
R3		47K, 1/2 Watt, Carbon
R4		8200Ω, 1 Watt, Carbon
R5		10K, 1/2 Watt, Carbon
R6		100K, 1/2 Watt, Carbon
R7		5600Ω, 1/2 Watt, Carbon
R8		27K, 1/2 Watt, Carbon
R9		1000Ω, 1/2 Watt, Carbon
R10		68Ω, 1/2 Watt, Carbon
R11		470K, 1/2 Watt, Carbon
R12		100K, 1/2 Watt, Carbon
R13		100K, 1/2 Watt, Carbon
R14		47K, 1/2 Watt, Carbon
R15		100K, 1/2 Watt, Carbon
R16		220K, 1/2 Watt, Carbon
R17		100K, 1/2 Watt, Carbon
R18		1.5 meg, 1/2 Watt, Carbon
R19		1800Ω, 1/2 Watt, Carbon
R20		22K, 1/2 Watt, Carbon
R21		1 meg, 1/2 Watt, Carbon
R22		10K, 1 Watt, Carbon
R23		1000Ω, 1/2 Watt, Carbon
R24		22K, 1/2 Watt, Carbon
R25		68Ω, 1/2 Watt, Carbon
R26		1 meg, 1/2 Watt, Carbon
R27		1 meg, 1/2 Watt, Carbon
R28		1 meg, 1/2 Watt, Carbon
R29		470K, 1/2 Watt, Carbon
R30		100K, 1/2 Watt, Carbon
R31		270K, 1/2 Watt, Carbon
R32		1800Ω, 1/2 Watt, Carbon
R33		1500Ω, 1/2 Watt, Carbon
R34		560K, 1/2 Watt, Carbon
R35		160K, 1/2 Watt, ± 5%, Carbon
R36		39K, 1/2 Watt, ± 5%, Carbon
R37		33K, 1/2 Watt, Carbon
R38		500Ω, 5 Watt, Wirewound
R39		500Ω, 5 Watt, Wirewound

COILS

L1	A30022	FM Antenna
L2	B30021	RF Choke
L3	A30020	RF Choke
L4	B30016	FM RF
L5	B30017	FM Osc.
L6	A30019	RF Choke
L7	C30506	1st FM IF
L8	C30507	2nd FM IF
L9	C30508	FM Ratio Det.
L10	B30010	Flt. Choke
L11	A30509	AM Antenna
L12	B30012	AM Osc.
L13	C30505	1st AM IF
L14	C30505	2nd AM IF
L15	B30018	Whistle Filter
L16	B30011	Choke
L17	B30011	Choke

TRANSFORMER

T1	B30510	Power
----	--------	-------

COMPONENT COMBINATIONS

K1	A37007	Printed Circuit
K2	A37000	Printed Circuit

MISCELLANEOUS

M1	A31060	3AG, 1 1/2 Amp Fuse
M2	C35015	FM Tuning Cap.
M3	C35014	AM Tuning Cap.
M4	A34510	B Channel Function Switch
M5	A34510	A Channel Function Switch
M6	A34509	Off-On Slide Switch SPDT
M7	A34509	115 VAC to 125 VAC Slide Switch SPDT
M8	31077	Pilot Light, GE #12
M9	31077	Pilot Light, GE #12
	A31081,	Dial Glass Panel
	A8352	Knob, Small
	A8246	Knob, Large

AMPLIFIER PARTS LIST

Ref. No.	Part No.	Description
----------	----------	-------------

TUBES

V11A	ECC83/ 12AX7	Intercom Preamp
V11B		A Channel Preamp
V12	ECC83/ 12AX7	AF Amplifier
V13A	ECC82/ 12AU7	A Channel Phase Inverter
V13B		B Channel Phase Inverter
V14	6AQ5A	A Channel Output
V15	6AQ5A	A Channel Output
V16	6AV6	B Channel Preamp
V17	ECC83/ 12AX7	AF Amplifier
V18	6AQ5A	B Channel Output
V19	6AQ5A	B Channel Output
V20	EZ80/ 6CA4	Rectifier

CAPACITORS

C46	B35006	40 mfd @ 350V, Electrolytic
C47A	B35007	40 mfd @ 350V, Electrolytic
C47B		40 mfd @ 350V, Electrolytic
C47C		10 mfd @ 350V, Electrolytic
C48A	B35008	50 mfd @ 50V, Electrolytic
C48B		250 mfd @ 50V, Electrolytic
C49		5000 mmf @ 500V, ± 20%, Ceramic Disc.
C50		1000 mmf @ 500V GMV, Ceramic Disc.
C51		220 mmf @ 1000V GMV, Ceramic Disc.
C52		220 mmf @ 1000V GMV, Ceramic Disc.
C53		33 mmf, ± 10%, N750, Ceramic Disc
C54		10000 mmf, +80% -20% Ceramic Disc.
C55		20000 mmf, +80% -20% Ceramic Disc.
C56		.013 mfd @ 200V, ± 10%, Tubular
C57		330 mmf @ 1000V, ± 10%, Ceramic Disc.
C58		2000 mmf @ 1000V, ± 10%, Ceramic Disc.
C59		1000 mmf @ 1000V, ± 10%, Ceramic Disc.
C60		10000 mmf, +80% -20% Ceramic Disc.
C61		10000 mmf +80% -20%, Ceramic Disc.
C62		10000 mmf +80% -20%, Ceramic Disc.
C63		10000 mmf +80% -20%, Ceramic Disc.
C64		47 mmf @ 1000V, ± 10% Ceramic Disc.
C65		10000 mmf, +80% -20%, Ceramic Disc.
C66		20000 mmf, +80% -20%, Ceramic Disc.
C67		.013 mmf @ 200V, ± 10%, Tubular
C68		330 mmf @ 1000V, ± 10%, Ceramic Disc.

Ref. No.	Part No.	Description
----------	----------	-------------

CAPACITORS (Cont'd)

C69		2000 mmf @ 1000V, ± 10%, Ceramic Disc.
C70		1000 mmf @ 1000V, ± 10%, Ceramic Disc.
C71		10000 mmf +80% -20%, Ceramic Disc.
C72		10000 mmf +80% -20%, Ceramic Disc.
C73		10000 mmf +80% -20%, Ceramic Disc.
C74		10000 mmf +80% -20%, Ceramic Disc.

CONTROLS

R40	B34008	500K, Potentiometer, Intercom Gain
R41A	B34006	500K, Potentiometer, Loudness, Dual
R41B		500K
R42A	B34005	500K, Potentiometer, Balance W/Switch, Dual
R42B		500K
R43A	B34004	2 meg, Potentiometer, Treble, Dual
R43B		2 meg
R44A	B34004	2 meg, Potentiometer, Bass, Dual
R44B		2 meg
R45	B34007	250Ω, Potentiometer, Hum Balance

RESISTORS

R46		10Ω, 1/2 Watt, Carbon
R47		10Ω, 1/2 Watt, Carbon
R48		10Ω, 1/2 Watt, Carbon
R49		47K, 1/2 Watt, Carbon
R50		270K, 1/2 Watt, Carbon
R51		680Ω, 1/2 Watt, Carbon
R52		1.2 meg, 1/2 Watt, Carbon
R53		470K, 1/2 Watt, Carbon
R54		2.2 meg, 1/2 Watt, Carbon
R55		6.8 meg, 1/2 Watt, Carbon
R56		100K, 1/2 Watt, Carbon
R57		4700Ω, 1/2 Watt, Carbon
R58		22K, 1/2 Watt, Carbon
R59		680K, 1/2 Watt, Carbon
R60		220K, 1/2 Watt, Carbon
R61		47K, 1/2 Watt, Carbon
R62		22K, 1/2 Watt, Carbon
R63		470K, 1/2 Watt, Carbon
R64		2200Ω, 1/2 Watt, Carbon
R65		1 meg, 1/2 Watt, Carbon
R66		1 meg, 1/2 Watt, Carbon
R67		4700Ω, 1/2 Watt, Carbon
R68		18K, 1/2 Watt, Carbon
R69		100K, 1/2 Watt, Carbon
R70		100K, 1/2 Watt, Carbon
R71		470K, 1/2 Watt, Carbon
R72		470K, 1/2 Watt, Carbon
R73		180Ω, 2 Watt, Wirewound
R74		680K, 1/2 Watt, Carbon
R75		220K, 1/2 Watt, Carbon
R76		6.8 meg, 1/2 Watt, Carbon
R77		100K, 1/2 Watt, Carbon

AMPLIFIER PARTS LIST (Cont'd)

Ref. No.	Part No.	Description
----------	----------	-------------

RESISTORS (Cont'd)

R78		4700Ω, 1/2 Watt, Carbon
R79		22K, 1/2 Watt, Carbon
R80		680K, 1/2 Watt, Carbon
R81		220K, 1/2 Watt, Carbon
R82		47K, 1/2 Watt, Carbon
R83		22K, 1/2 Watt, Carbon
R84		470K, 1/2 Watt, Carbon
R85		2200, 1/2 Watt, Carbon
R86		1 meg, 1/2 Watt, Carbon
R87		1 meg, 1/2 Watt, Carbon
R88		4700Ω, 1/2 Watt, Carbon
R89		18K, 1/2 Watt, Carbon
R90		100K, 1/2 Watt, Carbon
R91		100K, 1/2 Watt, Carbon
R92		470K, 1/2 Watt, Carbon
R93		470K, 1/2 Watt, Carbon
R94		1800Ω, 2 watt, wirewound
R95		2200Ω, 2 Watt, Wirewound
R96		3300Ω, 1/2 Watt, Carbon
R97		47K, 1/2 Watt, Carbon
R98		100Ω, 1/2 Watt, Carbon
R99		220K, 1/2 Watt, Carbon
R100		47Ω, 1/2 Watt, Carbon
R101		47Ω, 1/2 Watt, Carbon
R102		150Ω, 1/2 Watt, Carbon
R103		150Ω, 1/2 Watt, Carbon
R104		150Ω, 1/2 Watt, Carbon
R105		150Ω, 1/2 Watt, Carbon
R106		150Ω, 1/2 Watt, Carbon
R107		150Ω, 1/2 Watt, Carbon
R108		150Ω, 1/2 Watt, Carbon
R109		150Ω, 1/2 Watt, Carbon
R110		150Ω, 1/2 Watt, Carbon
R111		150Ω, 1/2 Watt, Carbon
R112		150Ω, 1/2 Watt, Carbon
R113		150Ω, 1/2 Watt, Carbon
R114		150Ω, 1/2 Watt; Carbon
R115		150Ω, 1/2 Watt, Carbon

Ref. No.	Part No.	Description
----------	----------	-------------

RESISTORS (Cont'd)

R116		150Ω, 1/2 Watt, Carbon
R117		150Ω, 1/2 Watt, Carbon
R118		47Ω, 1/2 Watt, Carbon

TRANSFORMERS

T2	B30502	Power
T3	B30504	Input
T4	B30503	A Channel Output
T5	B30503	B Channel Output

SPEAKER

SP3	B36005	Speaker, 3 1/2", Door Remote
-----	--------	------------------------------

MISCELLANEOUS

M10	A36501	Selenium Rectifier
M11	A31032	3AG 2 Amp Fuse
M12	A34509	115 VAC to 125 VAC Slide Switch SPDT
M13	A34507	ON - Auto Slide Switch SPDT
M14	B34508	4 Pole 3 Position Switch
M15	B34508	4 Pole 3 Position Switch
M16	B34508	4 Pole 3 Position Switch
M17	B34508	4 Pole 3 Position Switch
M18	B34508	4 Pole 3 Position Switch
M19	B34508	4 Pole 3 Position Switch
M20	B34508	4 Pole 3 Position Switch
M21	B34508	4 Pole 3 Position Switch
M22	B31030	4 Pole 1 Position Relay
M23	31015	Neon Lamp
	A31049	4 Screw Terminal Strip
	A31050	16 Screw Terminal Board
	A31055	Color Wire Coding Label
	A8245	Knob, Lever Switch
	A8246	Knob, Large

REMOTE CONTROL PARTS LIST

Ref. No.	Part No.	Description
----------	----------	-------------

RESISTORS

R119	A34003	50Ω, Potentiometer, A Channel Gain
R120	A34003	50Ω, Potentiometer, B Channel Gain
R121		150Ω, 1/2 Watt, Carbon
R122		150Ω, 1/2 Watt, Carbon
R123		150Ω, 1/2 Watt, Carbon
R124		150Ω, 1/2 Watt, Carbon
R125		150Ω, 1/2 Watt, Carbon
R126		150Ω, 1/2 Watt, Carbon

Ref. No.	Part No.	Description
----------	----------	-------------

SPEAKERS

SP1	C36004	Speaker, 8", A Channel
SP2	C36004	Speaker, 8", B Channel
	C36007	Speaker, 8", Patio Outside

MISCELLANEOUS

M24	A34505	1 Pole, Single throw, spring return switch
M25	A34506	2 Pole, Single throw, spring return switch
	A31025	Terminal strip
	A8267	Label, color code strip
	A8245	Knob, Lever switch
	A8265	Knob, small

MODEL 2403-B RECORD CHANGER

SERVICING INSTRUCTIONS

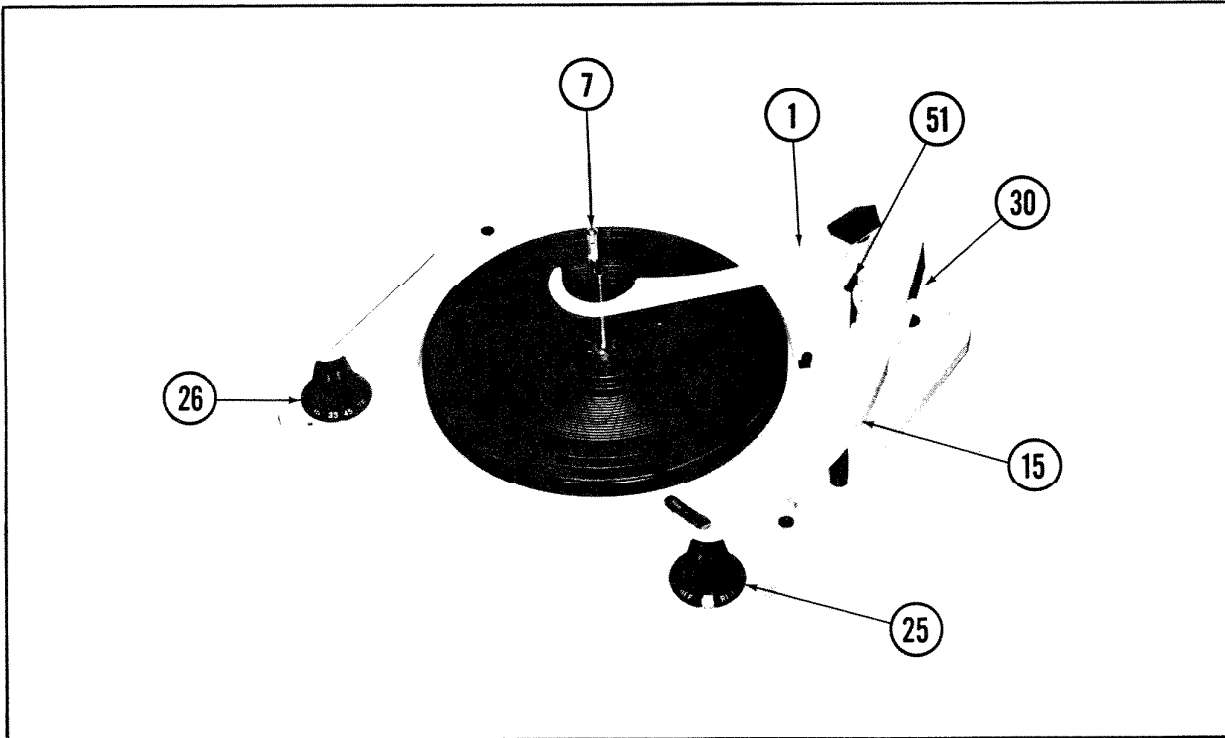

GENERAL INFORMATION

The Model 2403-B record changer plays a stack of records in automatic sequence and shuts off after playing the last record.

As many as ten 12-inch, twelve 10-inch, or ten 12-inch and 10-inch records intermixed (all 33 or all 78 rpm) may be loaded on the spindle.

A stack of fourteen 7-inch 45-rpm records (with a 45 adaptor spindle) will also play on this changer.

The 16 2/3 rpm records with 1 1/2-inch center holes can be played automatically; however, it is not advisable to allow the changer to shut off automatically after the last record has played.

The tone arm is equipped with a stereo cartridge.

Records are separated by movement of a finger in the center spindle. This finger directly separates records having a 1/4-inch center hole and actuates the knives and shelves of the spindle used for playing 45-rpm records.

The tripping method is the velocity type, requiring rapid tone arm acceleration to actuate the trip mechanism.

Connect the record changer to an outlet supplying 117 volts, 60 cycles AC only.

OPERATING INSTRUCTIONS

Loading

1. Pull straight up on record support (1) until it clears the spindle. Then swing the record support out over the tone arm.

2. Place records on spindle and lower to offset shelf. Hold records level and replace record support over spindle.

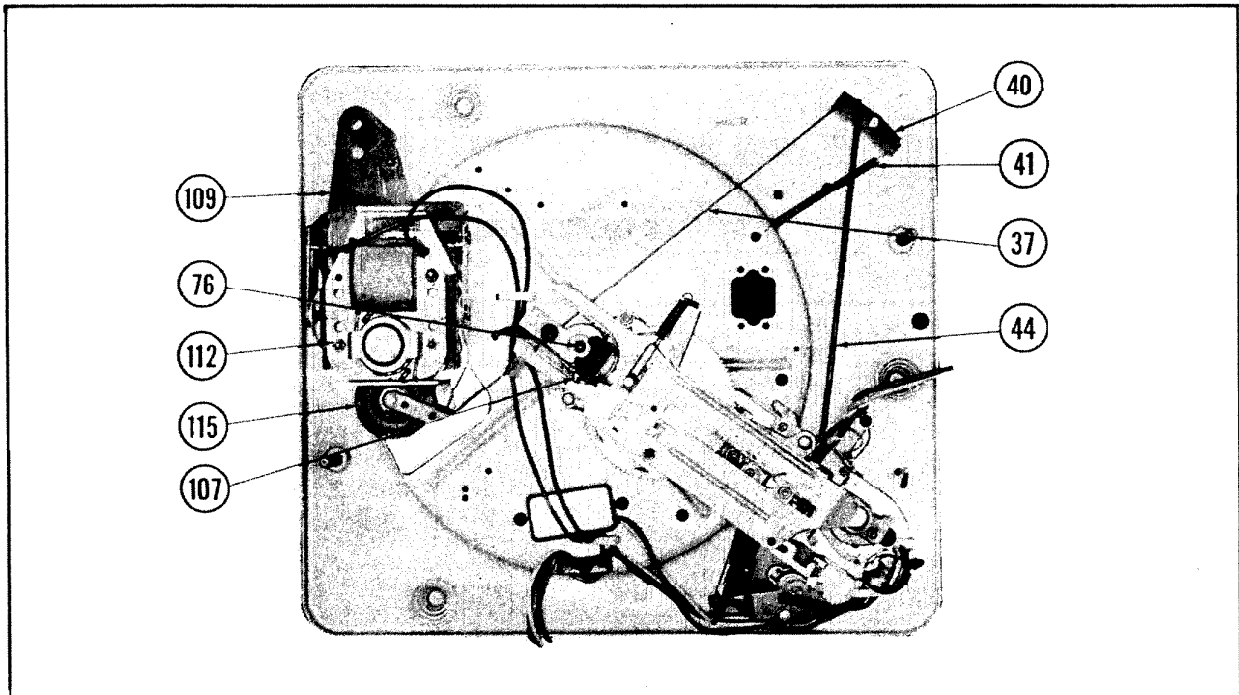

Fig. 2. Bottom View of Changer.

Starting

Make sure the stylus and speed controls are in the position corresponding to the type of records to be played. Then turn Off-On-Rej. knob to Rej. and release. The changer will play and change each record, and shut off automatically after the last record has been played.

Rejecting

To reject a record at any time while changer is operating, turn Off-On-Rej. knob to Rej. and release.

Unloading

Lift record support clear of spindle and swing out over tone arm. Using both hands, and with fingers under the edge of the bottom record, lift records straight up and off of spindle.

Manual Operation

Records without starting and fast-finishing grooves must be played manually. To play records manually, lift the record support arm and swing it to the right until it clears the turntable. Place record on spindle and lower to the turntable. Turn changer control knob to On position only. Gently place needle on record.

CHANGE CYCLE

Observe the change cycle operation while manually rotating the turntable. The following description can then be readily followed, and the function of each part more easily understood.

This changer has a velocity trip mechanism. The change cycle is started by the faster inward motion of the tone arm when the needle enters the trip grooves at the end of a record. Only records having fast-finishing grooves will operate this trip.

The tone arm and trip finger cam and shaft assembly (68) are connected so that they move in unison. As the tone arm nears the end of a record, trip finger cam (68) pushes trip link (95), engaging and pivoting trip lever (94). As trip lever (94) pivots, pawl lever (92) pivots with it and carries the trip pawl toward the turntable hub. While a record is playing, the small motions of the trip pawl are not sufficient to cycle the mechanism because, on each revolution of the turn-

table, the wiping contact by the hub projection moves the trip pawl back.

When the needle enters the record lead-out groove, the trip pawl is moved far enough to definitely engage the projection on the turntable hub. The con-

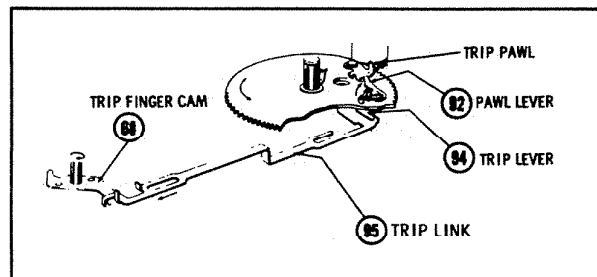

Fig. 3. Trip Mechanism Parts.

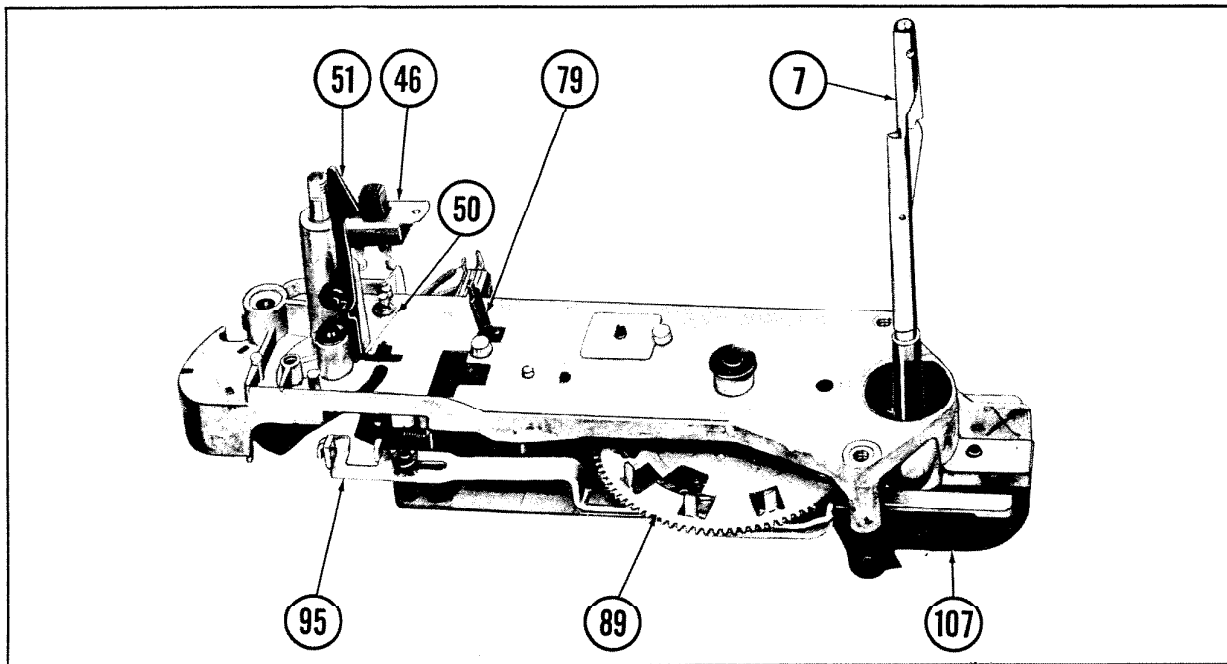

Fig. 4. Top View Of Cycling Mechanism.

tact between the trip pawl and turntable hub projection gives the necessary push for the teeth in main gear (89) to engage the teeth in the turntable hub, causing main gear (89) to rotate. This action starts the lateral travel of slide assembly (97). Slide assembly (97) is moved toward the rear by an eccentric mounted pin on main gear (89). This pin rides in the cross slot in slide assembly (97).

As the slide assembly begins to move, lift pin (23) rides up the incline on the rear of slide assembly (97), raising the tone arm. At the same time, trip finger cam (68) is pushed upward by lift pin spring (71), causing the two formed dimples in the trip finger cam to engage the two holes in tone arm return locator (64). This action controls the movement of the tone arm during the change cycle.

Slide assembly (97) continues to move away from the spindle until the formed end of slide (97) pushes against tone arm return locator (64). This action moves the tone arm out over tone arm rest (28).

A tab on the front of slide assembly (97) now contacts ejector bracket assembly (107). Ejector bracket (107) moves push rod (76) upward to acutate spindle assembly (7), dropping a record to the turntable.

Simultaneously, the trip pawl on top of main gear (89) contacts and rides along the curved finger of retard assembly (86). After leaving the finger of retard assembly (86), the trip lever assembly comes in contact with the trip link guide rivet. This action cams the pawl into the trip position again; however, before the change cycle is completed the trip pawl is reset by the tab located near the cross slot in slide (97).

At this time, the cam surface of the bracket on top of main gear (89) moves reset lever (81) to its midposition (10" setdown), where reset lever (81) is held by 12" record selector (51). Slide assembly (97) continues to the rear and then starts forward.

If 7" records are being changed, rubber bumper (54) and 7" setdown lever (79) are free to move upward. This action raises reset lever (81) to the upper position (7" setdown).

If 10" records are being changed, 7" setdown lever (79) will not rise, because rubber bumper (54) will contact the edge of the 10" record. Consequently, reset lever (81) remains in the midposition (10" setdown) as originally placed by the camming action of the bracket on top of main gear (89).

When a 12" record drops to the turntable, the record strikes 12" record selector (51) and pivots the selector toward the rear of the changer. This action disengages the end of reset lever (81) from the edge of 12" record selector (51) and permits reset lever (81) to drop into the recess at the bottom of 12" record selector (51). Reset lever (81) then engages the bottom step of tone arm return locator (64), positioning the tone arm for 12" setdown.

As slide assembly (97) continues forward, the tab on the rear of the slide moves clear of tone arm return locator (64) and trip finger cam (68), which are still locked together. This action permits tone arm return spring (61) to move the tone arm inward until one of the three setdown steps in tone arm locator (64) strikes reset lever (81), stopping the inward travel of the tone arm directly above the point of landing. The tone arm is then lowered to the lead-in groove of the record as lift pin (23) rides down the incline on the rear of slide assembly (97). As pressure is released from lift pin spring (71), trip finger cam (68) and tone arm return locator (64) separate, permitting the tone arm to track freely across the record.

After the record has played and the mechanism trips, the preceding sequence of cycling and playing of

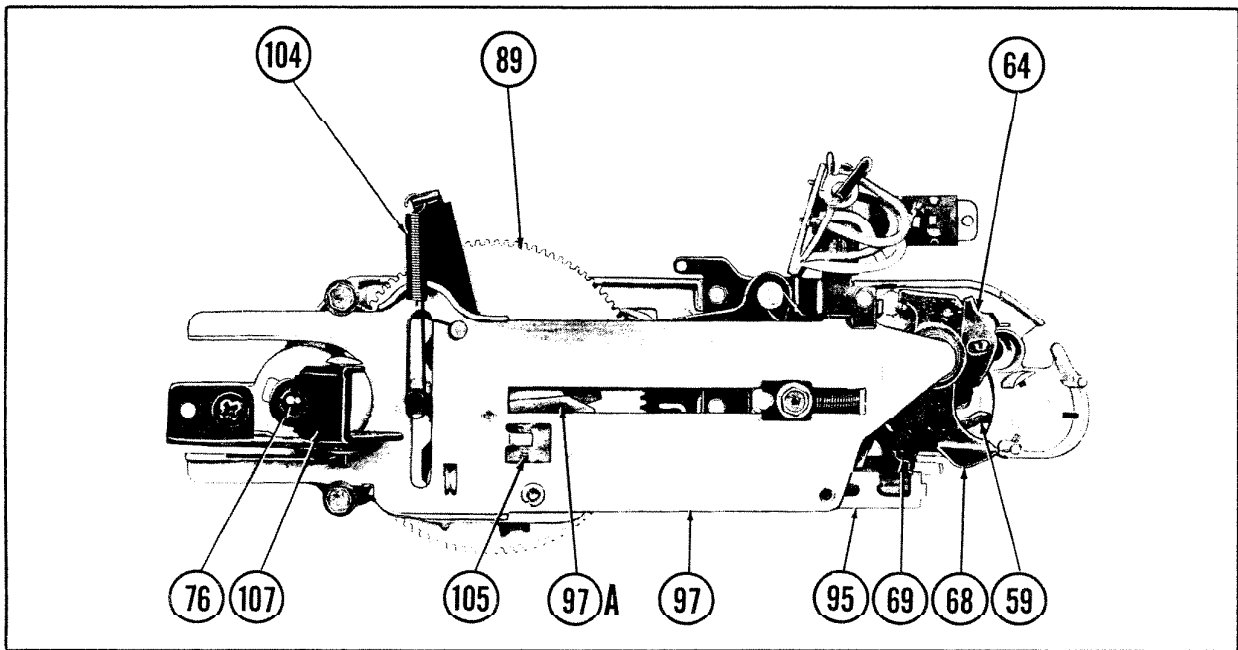

Fig. 5. Bottom Biew Of Cycling Mechanism.

records is again followed until only the last record of the stack remains on the spindle shelf.

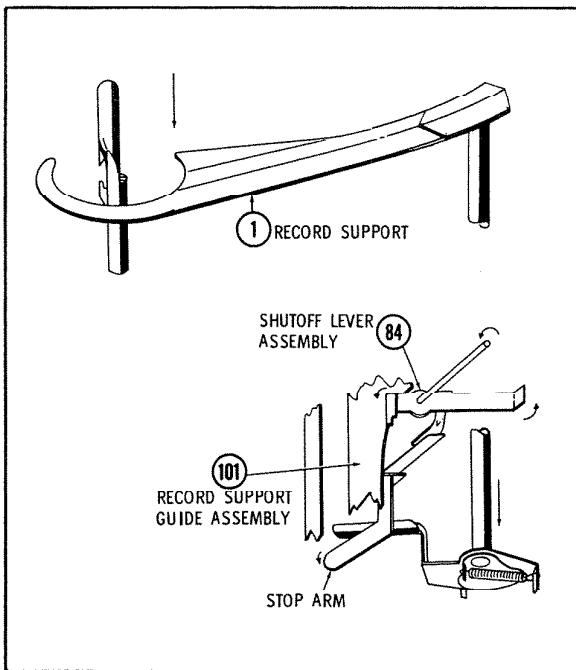

Fig. 6. Shutoff Mechanism Parts.

As the last record of the stack drops to the turntable, record support (1) drops below the shelf on

spindle assembly (7), and the lower end of record support shaft (103) contacts the stop arm on record support guide assembly (101). The stop arm in turn applies force to shutoff lever (84). At this moment, cycling slide (97) is in its outermost position (away from the spindle), and the end of shutoff lever (84) is forced against escape lever (97A), preventing shutoff lever (84) from lowering further.

As cycling slide (97) returns to the out-of-cycle position, the end of shutoff lever (84) slides off escape lever (97A), permitting the end to extend down through the slot in the cycling slide. By this time, tone arm locator (64) has rotated too far to be blocked by shutoff lever (84), and the tone arm is permitted to land on the record.

After the last record has played, the mechanism again goes into cycle. When cycling slide (97) has reached its outermost position, the force applied to shutoff lever (84) from record support shaft (103) causes the end of shutoff lever (84) to extend through the slot in cycling slide (97). The other end of shutoff lever (84) rises and prevents tone arm locator (64) from rotating. This action positions the tone arm directly over tone arm rest post (28).

As cycling slide (97) moves back toward the spindle, trip link (95) pushes control lever (59), actuating power switch (60). Thus, power is removed from the motor, stopping the mechanism.

As slide assembly (97) returns to the out-of-cycle position, lift pin (23) rides down the slide incline and lowers the tone arm onto rest post (28).

LUBRICATION

Additional lubrication should not be required for the life of the changer. However, if the changer has

had extreme usage, or if parts are replaced, lubricate as follows:

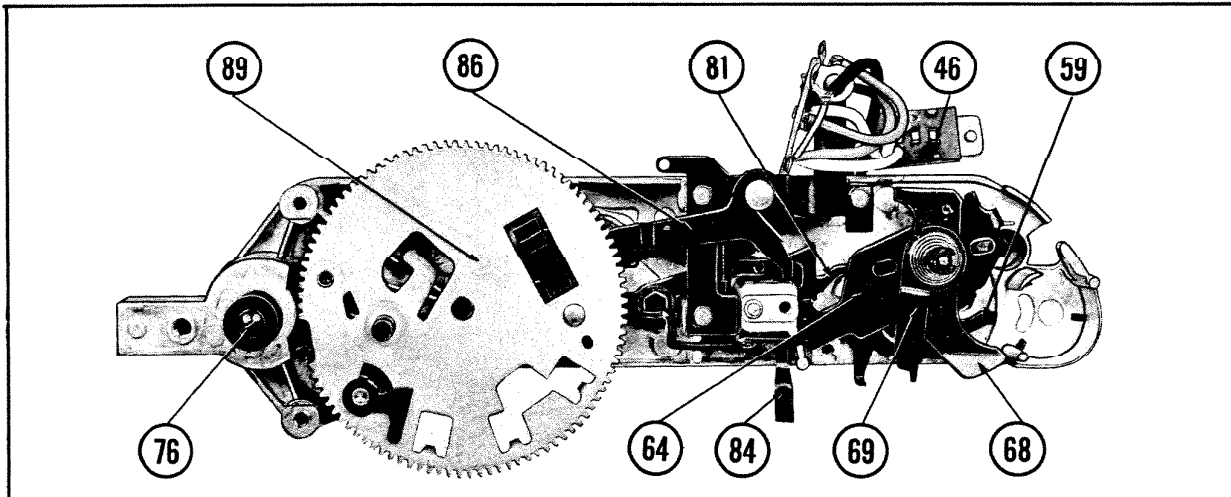

Fig. 7. Bottom View Of Cycling Mechanism With Slide Removed.

Apply Andok 'B' or Texaco Sta-Put to:

1. Edges of all slots in slide assembly (97).
2. Outer edges of tines on forked end of slide assembly (97).
3. Lift pin cam surface on slide assembly (97).
4. Lower surface of tone arm return locator (64).

5. Inner surface of tab on rear of slide assembly (97).

Apply one drop of light mineral oil to:

1. Trip finger cam shaft (68).
2. Push rod (76).
3. Top and bottom motor bearings.

ADJUSTMENTS

Needle Setdown (Refer to Fig. 8.)

The setdown position of the needle is adjusted by setdown adjustment screw (24A). Turn this screw until setdown is correct for a 10-inch record. When 10-inch setdown is correct, the 12-inch and 7-inch setdown will also be correct.

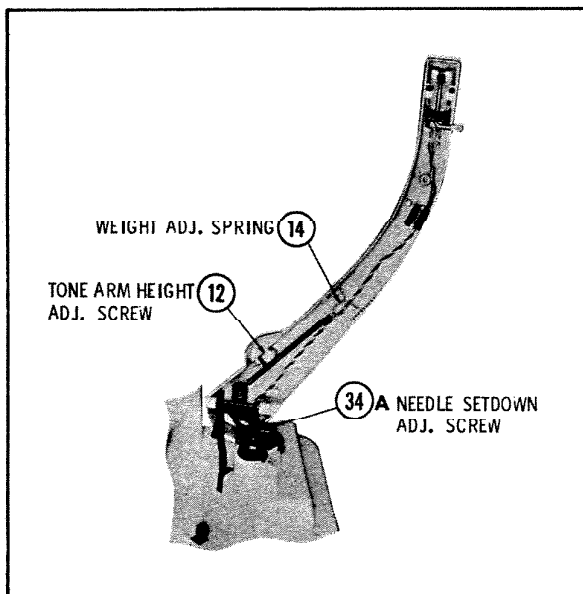

Fig. 8. Tone Arm Adjustment Points.

Tone Arm Height (Refer to Fig. 8.)

The tone arm height is adjusted by lift screw (12). To raise tone arm, turn this screw counterclockwise. To lower tone arm, turn screw clockwise. The tone arm height should be adjusted so that, with a 1 1/8" stack of records on the turntable, the tone arm lifts 1/4" straight up as the change cycle starts.

Needle Pressure (Refer to Fig. 8.)

Needle pressure should be between 6 and 8 grams. To adjust, place weight adjustment spring (14) in the proper slot in the tone arm.

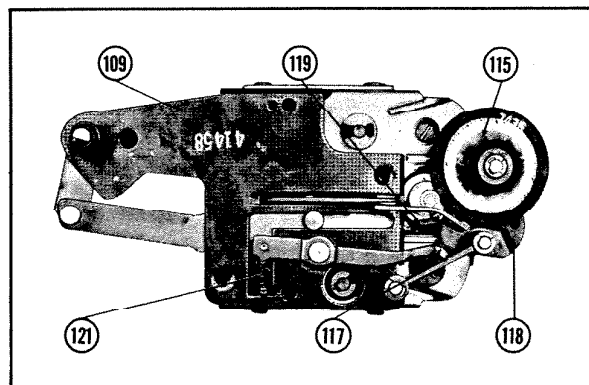

Fig. 9. Top View Of Motor.

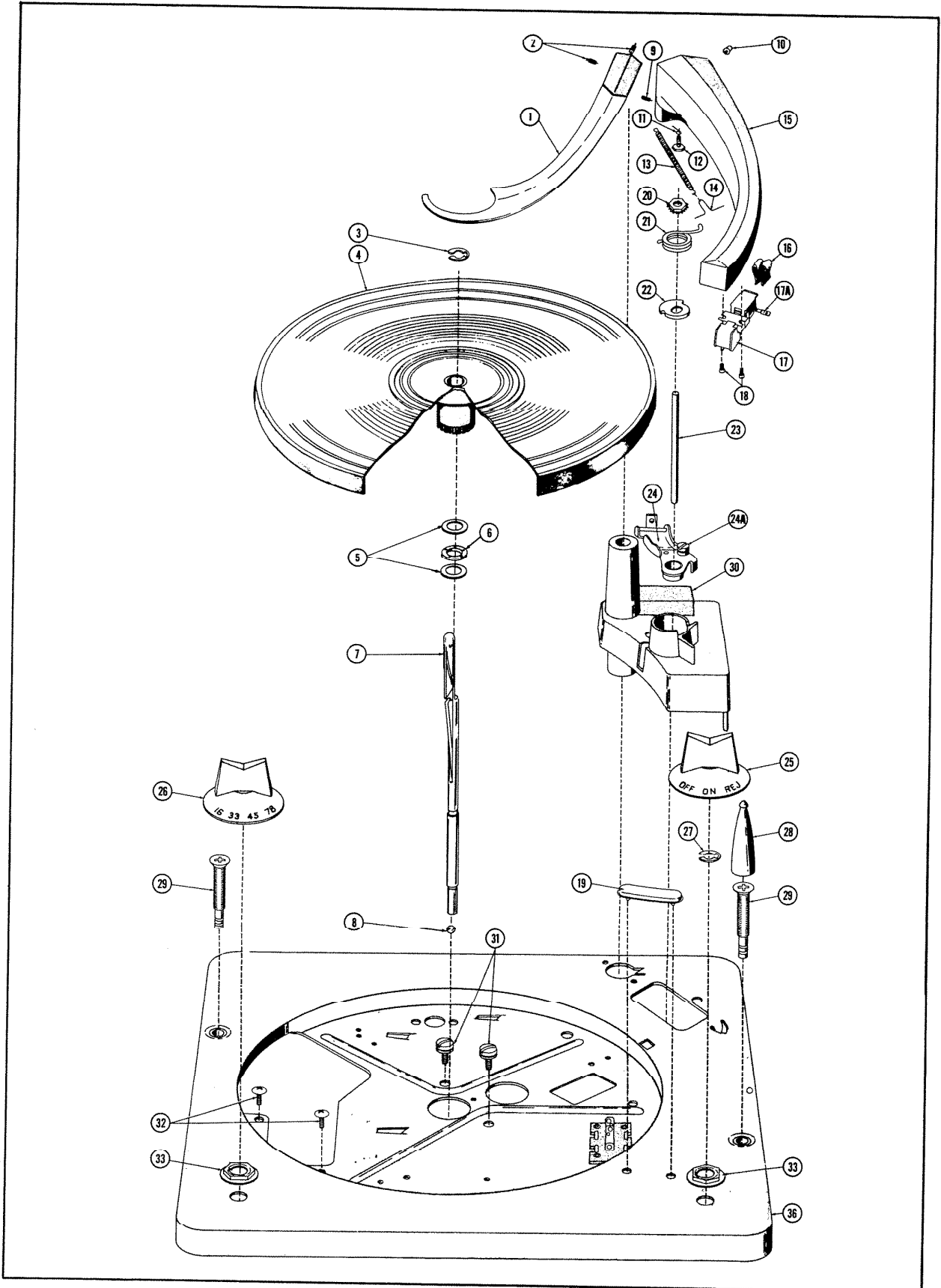

Fig. 10A. Exploded View of Parts Above Baseplate.

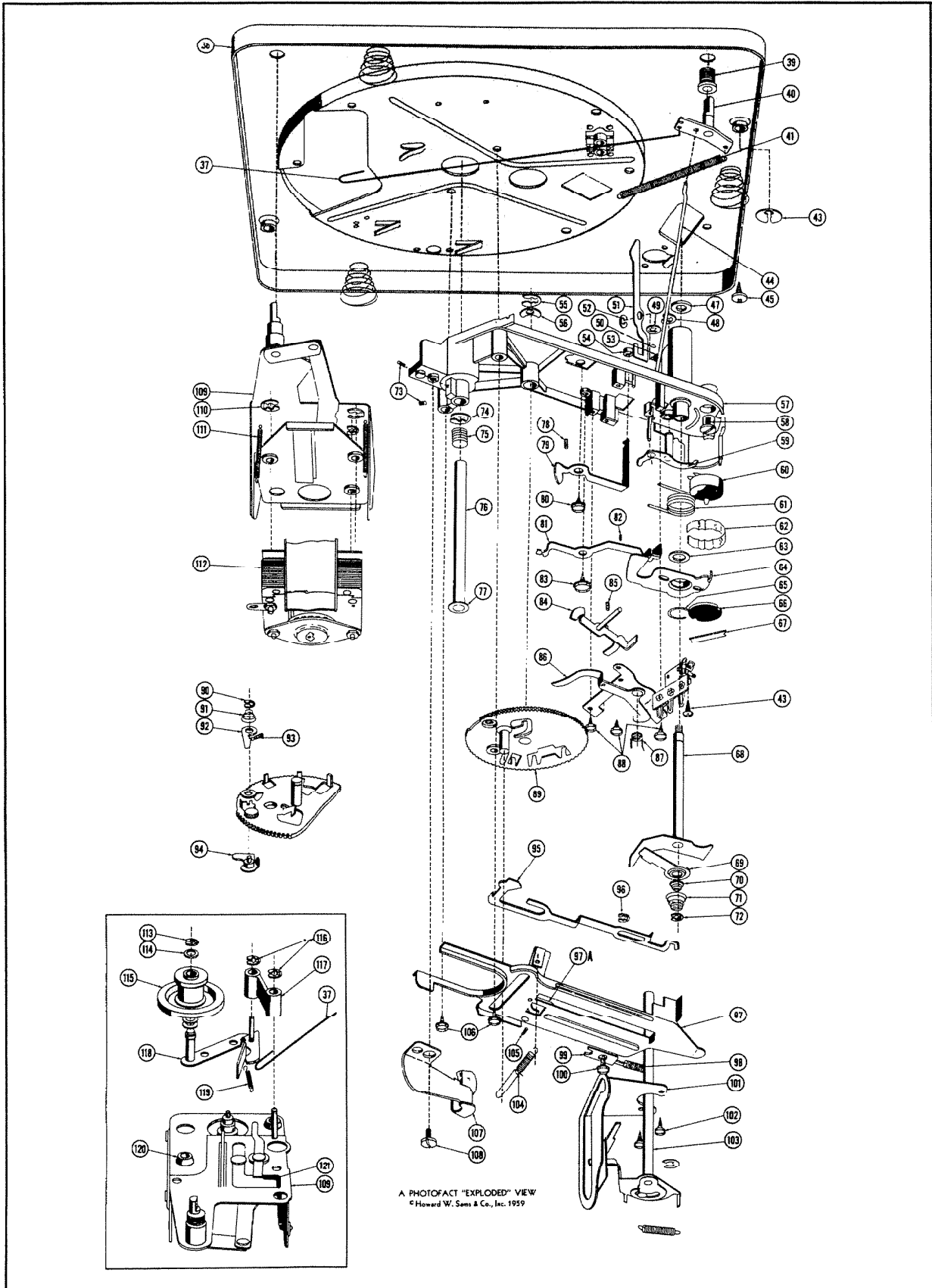

Fig. 10B. Exploded View of Parts Below Baseplate.

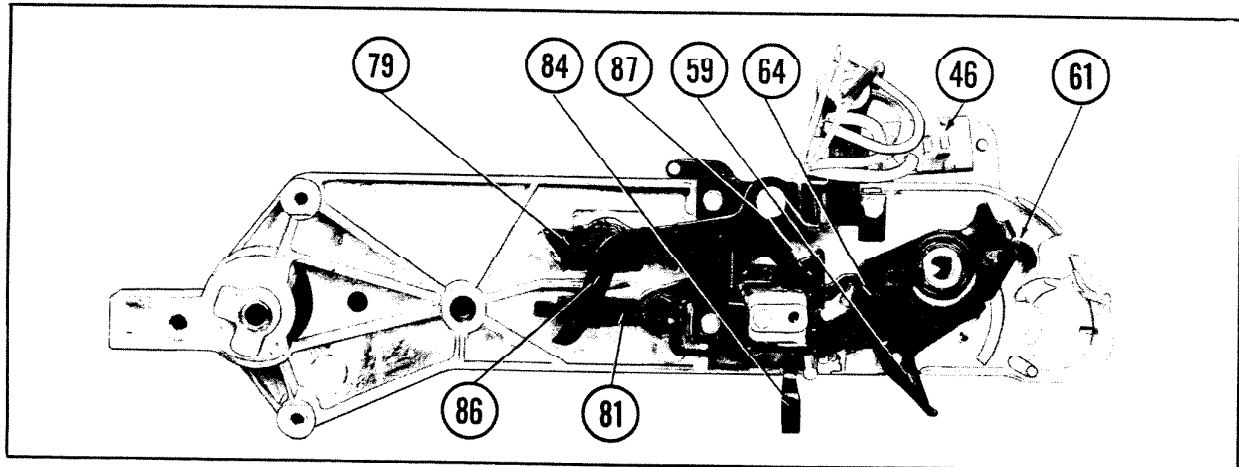

Fig. 11. Bottom View of Cycling Mechanism With Slide and Cam Gear Removed.

TROUBLE CHART

SYMPTOM	CAUSE	REMEDY
Turntable does not revolve when control is turned to "On" position.	1. No current at motor.	(a) Check that current is reaching AC leads of changer. (b) Check that switch is closing. (c) Check wiring and soldered terminals in the changer.
	2. Motor defective.	(a) Remove turntable to allow motor to operate without load. If current is reaching motor and drive spindle does not rotate, the motor is defective. Repair or replace.
	3. Motor idler wheel not engaging turntable wheel.	If drive spindle is turning but turntable is not: (a) Check motor idler assembly to determine if it is free to contact the drive spindle and turntable rim. (b) Wipe off inside rim of turntable (4) to remove dust, or if oily, clean the turntable rim and rubber tire of the idler wheel with naphtha or alcohol.
Changer does not cycle when the control knob is turned to the "Rej." position.	1. The manual reject not actuating the trip.	(a) Turn control knob (25) to the reject position; hold and see that control shaft assembly (59) has moved trip link (95) to the rear. This should actuate the trip pawl on main gear (89) which will bring the spur on the trip pawl in contact with the gear on the turntable hub. (b) Check for binding of pawl lever (92), trip lever assembly (94) and the trip pawl. If binding occurs, clean out all foreign matter and check for freedom.
Control knob cannot be turned to "On" position.	1. Machine shut off during cycle.	Turn the turntable clockwise, by hand, until control knob (25) is free.
Tone arm strikes records on spindle when it raises, or tone arm rest when it moves out.	1. Tone arm height not adjusted properly.	(See instructions for adjusting tone arm height under "Adjustments".)

TROUBLE CHART (Con't.)

SYMPTOM	CAUSE	REMEDY
Turntable speed too slow (refer to exploded view).	1. Binding in turntable bearing.	Check the turntable bearing for freedom. Hold the motor idler wheel out of engagement with the turntable and spin the turntable, by hand, to see if it turns readily and coasts for a long time. If binding occurs, remove turntable, clean off foreign matter, and lubricate with light mineral oil.
	2. Line voltage too low.	The line voltage should not be less than 105 volts or the turntable may be too slow.
Turntable stalls or slows down during cycle; refer to exploded view.	1. Motor idler not engaging turntable.	(See "Turntable Does Not Revolve When Control Knob is Turned to 'On' Position" .)
	2. Binding in drive mechanism.	Hold idler away from turntable, or remove idler wheel. Cycle machine by turning turntable slowly by hand. The main gear should turn freely for the complete revolution without binding at any point. (a) If binding occurs, check for foreign matter in the gear teeth, a bent gear bearing, or bent spindle bushing. Straighten or replace. Clean and lubricate.
	3. Binding between pick-up arm lift pin (23) and lift pin cam surface on slide and cam assembly.	Lift pin should ride freely on cam surface without binding.
	4. Motor weak.	When everything checks all right, but the changer still stalls in cycle, the motor may be weak.
	5. Grease on idler wheel.	Wipe off idler wheel rubber tire, inner rim of turntable and motor pulley with naphtha or alcohol.
	6. Idler wheel tension spring weak.	Replace spring.
Changer continues to cycle.	Reject mechanism binding.	(a) Make certain trip link (95) is not frozen in the reject position.
		(b) Make certain changer control lever (59) is not binding and that it actuates trip link (95) when the changer control knob (25) is turned to reject.
		(c) Check for binding of trip pawl, trip lever (94) and pawl lever (92); these must be free to turn easily.
		(d) Check the changer control linkage, (44) and (59).
Noise during playing of record.	1. Motor rumble.	If a low-pitched rumbling sound comes from the loud speaker while a record is being played, check motor grommets to be sure the motor is freely suspended on them. The motor lead wires should have slack to allow the motor to float. Motor rumble may also come from an unbalanced motor rotor; in this case, replace the motor.
	2. Defective turntable bearings (6).	Defective turntable bearings can cause rumble. Check for foreign matter in the bearing; also check for defective balls, binding between balls and ball retainer, and rough surface on washers. Clean ball bearing, sleeve bearing, and washers; lubricate with light mineral oil.

TROUBLE CHART (Con't.)

SYMPTOM	CAUSE	REMEDY
	3. Defective motor idler	A rapid thumping sound while the motor is running may indicate a flat spot on the motor idler wheel. If this condition does not clear up after ten minutes of running time, remove the turntable and check the rubber tire on the idler. If the surface of the rubber tire is not smooth and even, replace the part. Should the bearing of the idler wheel show signs of excessive wear or be extremely wobbly, the idler wheel should be replaced.
	4. Turntable scrapes.	If a scraping sound occurs as the turntable revolves, check; <ul style="list-style-type: none"> (a) Turntable warped, causing outer rim to rise and fall. (b) Motor idler or mounting plate bent.
	5. Squeaks.	Squeaking sound as changer operates indicates lack of oil. Lubricate points indicated under "Lubrication" .
Changer does not shut off after last record has been played.	1. Record support (1) binding.	The record support must drop below the off-set shoulder of the spindle or the changer will not shut off.
	2. Lever assembly (84) binding.	Clean out dirt and make sure lever operates smoothly.
	3. Shut-off bracket binding.	Check bracket and if bent, straighten.
	4. Shut off lever not engaging locator.	Adjust tab on slide that rotates the locator and trip finger when unit is cycling.
Rough tone arm motion.	1. Horizontal defects.	(a) Check tone arm return locator (64) for tightness.
		(b) Check that tone arm return spring (61) is not weak and is hooked up properly.
	2. Vertical defects.	(a) Lift pin (23) binding; clean out dirt and lubricate.
		(b) Slide and cam (97) binds; check bearing points — clean and lubricate.
		(c) Burrs in main slot in slide and cam (97) — remove with fine file.
	(d) Ejector lever on ejector bracket assembly (107) binding. Straighten, remove burrs, and lubricate.	
	(e) Tone arm shaft and sleeve binding; clean and lubricate.	
Noise during change cycle.	1. Tines on the forked end of the slide and cam assembly (97) bent.	Replace.
	2. Lack of lubrication. Grinding noise.	Lubricate ejector lever (107) where it contacts lower end of push rod (76).
Shuts off when last record drops.	1. Shut-off bracket (101) bent.	Straighten or replace.
	2. Record support bent.	Bend record support (1) until parallel with baseplate.
	3. Loose shut-off lever assembly (84).	Tighten
	4. Escape lever spring 105 missing.	Replace.

TROUBLE CHART (Con't.)

SYMPTOM	CAUSE	REMEDY
Record does not drop when changer cycles.	1. Spindle push rod (76) broken, or bent.	Replace push rod (76).
	2. Record finger in spindle not moving far enough to eject a record.	The record finger should move forward until it has reached a point flush with, or a maximum of, .010 beyond the spindle body (7). To insure that the record finger is all the way forward, push rod (76) should be raised high enough by the ejector lever to slightly compress the pusher spring. (See "Turntable Stalls During Cycle".) If the spring is compressed and the record finger does not move far enough forward to eject a record, the spindle (7) should be replaced. If a record is not pushed completely off the ledge it may hang on the spindle momentarily, then drop on the tone arm when it moves in over the turntable.
	3. Check that ball bearing (8) is not missing.	Replace.
Two records drop at once.	1. Hole in record too large.	Check the diameter of the hole in the record. An oversize hole will cause two records to drop at once.
	2. Spindle guide not fully down.	If the spindle guide is not all the way down, more than one record may drop at a time. (a) Check the guide to be sure it is free and does not bind at any point. Clean out foreign matter or straighten if necessary. Do not oil. (b) When records are placed on the spindle, be sure the guide is all the way down. The guide will normally raise as a record is being dropped, but it should return to place immediately, by gravity.
	3. Slight play in spindle (7).	Tighten spindle set screw (73).
Record hits tone arm.	1. Record finger not moving far enough forward to eject record.	(See "Record Does Not Drop When Changer Cycles".)
	2. Record finger extending beyond outside diameter of spindle.	Cycle changer, by hand, until pusher shaft is at the top of its travel. Using new record as a gauge, pass it over the spindle to see if it binds at any point. File off high points on record finger with a fine file, until record will pass freely over spindle.
	3. Tone arm not adjusted properly.	(See "Adjustments".)
Needle does not set down on 10" record in proper position.	1. Tone arm not adjusted properly.	(See "Adjustments" .) (a) Loose nut (20) on pickup arm shaft and sleeve (68).
	2. Tone arm shaft and sleeve (68) binding.	File off burrs and rough surfaces. Polish and lubricate shaft.
	3. 7" set-down lever (79) and 12" record selector (51) not operating properly.	Insure that the proper operation and reset of the 7" set-down lever (79) and 12" record selector (51) is not being interfered with.

TROUBLE CHART (Con't.)

SYMPTOM	CAUSE	REMEDY
	4. Needle bent.	Replace with new needle.
	5. Wire spring (50) broken.	12" record selector (51) does not cock; check for broken 12" record selector spring (50).
	6. Bent tone arm return locator (64).	Straighten or replace.
	7. Bent trip finger cam (68).	Straighten or replace.
Needle does not set down on 12" record in proper position.	1. Diameter of 12" record undersize.	The set-down position of the needle for 12" records is determined by the edge of the record striking the 12" record selector (51). If a 12" record has a diameter of less than the standard size of 11-7/8" plus or minus 1/32", it may fail to depress the 12" record selector far enough.
	2. Enlarged center hole in record.	An enlarged center hole might fail to set the 12" record selector because it could produce the same effect as a small record.
	3. Tone arm not adjusted properly.	(See "Adjustments".)
	4. Binding of tone arm shaft and sleeve (68).	Clean and polish shaft (68) and lubricate with light oil.
	5. Reset lever spring (82) broken.	Replace spring (82).
	6. 12" record selector spring (50) broken.	Replace spring (50).
	7. 12" record selector (51) binding.	The 12" record selector must be free to operate smoothly. Clean out dirt and straighten if bent, or replace.
	8. Bent tone arm return locator (64).	Straighten or replace.
	9. Bent trip finger cam (68).	Straighten or replace.
Needle does not set down on 7" record properly.	1. 7" set-down lever spring (78) broken or weak.	Replace.
	2. Tone arm not adjusted properly.	(See "Adjustments".)
	3. 7" set down lever screw (80) loose.	Tighten.
	4. 7" set-down lever (79) hitting frame or base-plate where it goes through hole in frame.	Straighten or replace.
	5. Reset lever (81) bent.	Replace.
	6. 7" set-down lever (79) does not fall into opening in main gear.	Replace.
	7. Bent tone arm return locator (64).	Straighten or replace.

TROUBLE CHART (Con't.)

SYMPTOM	CAUSE	REMEDY
	8. Bent trip finger cam (68).	Straighten or replace.
Changer does not cycle when record has been played.	1. No finishing trip groove on record.	Check record for eccentric trip groove in center of record. Some old records and home recordings do not have this eccentric trip groove.
	2. Needle jumps out of grooves in record.	(a) Check trip pressure; the lateral pressure should not exceed 3 grams, (if pressure is excessive, see "Changer Trips Before Needle Reaches End of Record"). (b) The record may be defective; the finishing groove is often too shallow. Check with a record that is known to be good. (c) The needle point may be damaged or affected by an excessive accumulation of dust, lint, etc; check needle pressure as described under "Adjustments". (d) There may be binding in the tone arm shaft and sleeve assembly (68) or between the tone arm return locator (64) and the trip finger cam (68); (See "Needle Does Not Track Properly Across Record).
	3. Trip pawl binding on gear face.	The trip pawl must be free to move forward and engage the boss on the turntable hub when the trip lever releases it. Check for burrs or foreign matter lodged between the trip pawl and main gear (89). Do not oil as this might collect dirt and gum up the pawl.
	4. Trip finger cam (68) bent.	Straighten or replace.
	5. Trip link (95) bent.	Straighten or replace.
Changer trips before needle reaches end of record.	1. Hole in record too large.	If the hole in the record is too large, the groove may turn eccentric with the spindle and cause premature tripping.
	2. Binding of trip link (95).	With the trip link released, check the trip link for freedom of motion. It should be free to move without binding.
Needle does not track across record properly.	1. Needle may be clogged by accumulation of lint, dirt, etc, or worn.	(a) Clean foreign material from around needle. (b) Check needle to see if the tip is bent or broken. Replace if necessary.
	2. Trip finger cam (68) does not disengage from the tone arm return locator (64) when cycle is completed.	There should be a 1/32" gap between the trip finger cam (68) and the tone arm return locator (64) when the machine is not in cycle.
	3. Check the bearing in the tone arm post for binding.	(a) Check tone arm return locator (64) and trip finger cam (68) for binding (See 2 above).
	4. Pickup leads too tight.	Give the pickup leads enough slack to allow the tone arm to move freely across a record.

RECORD CHANGER PARTS LIST

Ref. No.	Part No.	Description
1	N-23534D	Record Support
2	N-14603	Set Screw
3	N-1650	"C" Washer, Turntable Retainer
4	*N-9455	Turntable Assembly
5	N-6877	Bearing Washer
6	N-6876	Bearing Retainer
7	N-6049	Spindle Assembly
8	N-6884	Spindle Ball Tone Arm & Hinge Ass'y.
9	N-4923	Pivot Screw
10	N-4922	Hinge Button
11	N-7634	Lock Spring
12	N-7635	Lift Screw
13	N-14431	Hinge Spring
14	N-15293	Weight Adjusting Spring
15	*N-19111	Tone Arm
16	N-6963	Tone Arm Clip
17	N-36021	Cartridge
17A	N-36020	Needle Unit
18	N-18427	Cartridge Mounting Screw
19	N-9375	Needle Protector
20	N-14498	Keps Nut
21	N-4937	Safety Spring
22	N-4339	Safety Plate
23	N-4327	Lift Pin
24	N-4072	Hinge Arm Assembly
24A		Set Down Adj. Screw (Part of Item 24)
25	N-16704A46	Knob, On-Off Rej.
26	N-16793A46	Knob, Speed Control
27	N-1719	"C" Washer
28	*N-5573	Rest Post
29	N-15044	Mounting Bolt
30	N-8404	Rubber Pad, Tone Arm
31	N-9823	Screw, Works Assembly Mounting
32	N-6929	Screw, Motor Assembly Mounting
33	N-8398	Pal Nut
36	*N-19001	Baseplate Assembly
37	N-16810	Retraction Rod
39	N-6916	Control Bushing
40	N-7114	Control Lever Assembly
41	N-7113	Reject Spring
43	N-1736	"C" Washer (Mounting Bolts)
44	N-6919	Reject Rod
45	N-2916	Screw, Rest Post Mounting
47	N-2952	Fiber Washer
48	N-1652	"C" Washer
49	N-1720	Speed Nut
50	N-2563	Spring, 12" Record Selector
51	N-2957	12" Record Selector
52	N-1588	"C" Washer
53	N-4172	Spring, 12" Selector
54	N-2580	Rubber Bumper
55	N-1719	"C" Washer, Gear Mounting
56	N-9762	Spring Washer, Gear Mounting
57	N-15451	Frame Assembly
58	N-9823	Screw
59	N-2284	Control Shaft Assembly
60	N-467	AC Switch
61	N-9533	Return Spring
62	N-2931	Fiber Insulating Strip

Ref. No.	Part No.	Description
63	N-4950	Fiber Washer (Part of Item 64)
64	N-6405	Locator and Bushing Assembly
65	N-5828	Locator Ring
66	N-2573	Switch Cover
67	N-4212	Retainer, Switch Cover
68	N-15450	Finger and Shaft Assembly
69	N-9557	Retard Lever
70	N-9510	Anti-Skate Spring
71	N-9509	Lift Pin Spring
72	N-1588	"C" Washer
73	N-6955	Set Screw
74	N-5022	"C" Washer
75	N-6885	Safety Spring
76	N-6874	Push Rod
77	N-6883	Thrust Washer
78	N-2579	Spring, 7" Lever
79	N-2581	7" Lever
80	N-9849	Screw
81	N-6007	Reset Lever
82	N-2925	Spring, Reset Lever
83	N-9849	Screw
84	N-6966	Shut-Off Lever Assembly
85	N-9663	Spring, Shut-Off Lever
86	N-19154	Retard Assembly
87	N-16817	Spring, Retard Arm
88	N-6713	Screw
89	N-7125	Gear Assembly
90	N-1588	"C" Washer
91	N-4172	Spring
92	N-5339	Pawl Lever
93	N-5338	Spring, Pawl Lever
94	N-2569	Trip Lever Assembly
95	N-4656	Trip Link
96	N-1588	"C" Washer
97	N-7121	Slide Assembly
97A		Escape Lever (Part of Item 97)
98	N-2246	Spring, Slide Bearing
99	N-2211	Slide Bearing
100	N-9849	Screw
101	N-6931	Record Support Guide Assembly
102	N-4857	Screw
103		Record Support Shaft
104	N-7120	Detent Spring and Link Assembly
105	N-2585	Spring, Escape Lever
106	N-9849	Screw
107	N-14420	Ejector Bracket
108	N-9823	Screw
	N-18361	Motor Assembly, Complete, 117V, 60 Cycle
109	N-18398	Motor Plate Assembly
110	N-5022	"C" Washer
111	N-7434	Counter Balance Spring
112	N-9134	Motor
113	N-1652	"C" Washer
114	N-2583	Fiber Washer
115	N-19388	Idler Pulley
116	N-1652	"C" Washer
117	N-7437	Idler Link
118	N-7438	Idler Arm Assembly
119	N-7439	Idler Spring
120	N-6631	Motor Mounting Grommet
121	N-6947	Detent Spring

Nutone

Supplemental Information

MODELS 2401-2402-N2402

Stereo and Intercom High Fidelity Systems

AMPLIFIER CHASSIS—MODEL 2401

The tone control circuit of both channels has been revised in later productions. Refer to the partial schematic of Fig. 1 for the new circuit diagram. The following parts have been changed or added. Please mark the parts list accordingly:

- Change:
 C53 33 mmf, $\pm 10\%$, N750, Ceramic Disc
 To:
 C53 47 mmf, $\pm 10\%$, N750, Ceramic Disc
- Change:
 C64 47 mmf @ 1000V, $\pm 10\%$, Ceramic Disc

- To:
 C64 100 mmf @ 1000V, $\pm 10\%$, Ceramic Disc
- Change:
 R59 680K, $\frac{1}{2}$ Watt, Carbon
- To:
 R59 470K, $\frac{1}{2}$ Watt, Carbon
- Add:
 C75 33 mmf @ 1000V, $\pm 10\%$, Ceramic Disc
 C76 100 mmf @ 1000V, $\pm 10\%$, Ceramic Disc
 C77 100 mmf @ 1000V, $\pm 10\%$, Ceramic Disc

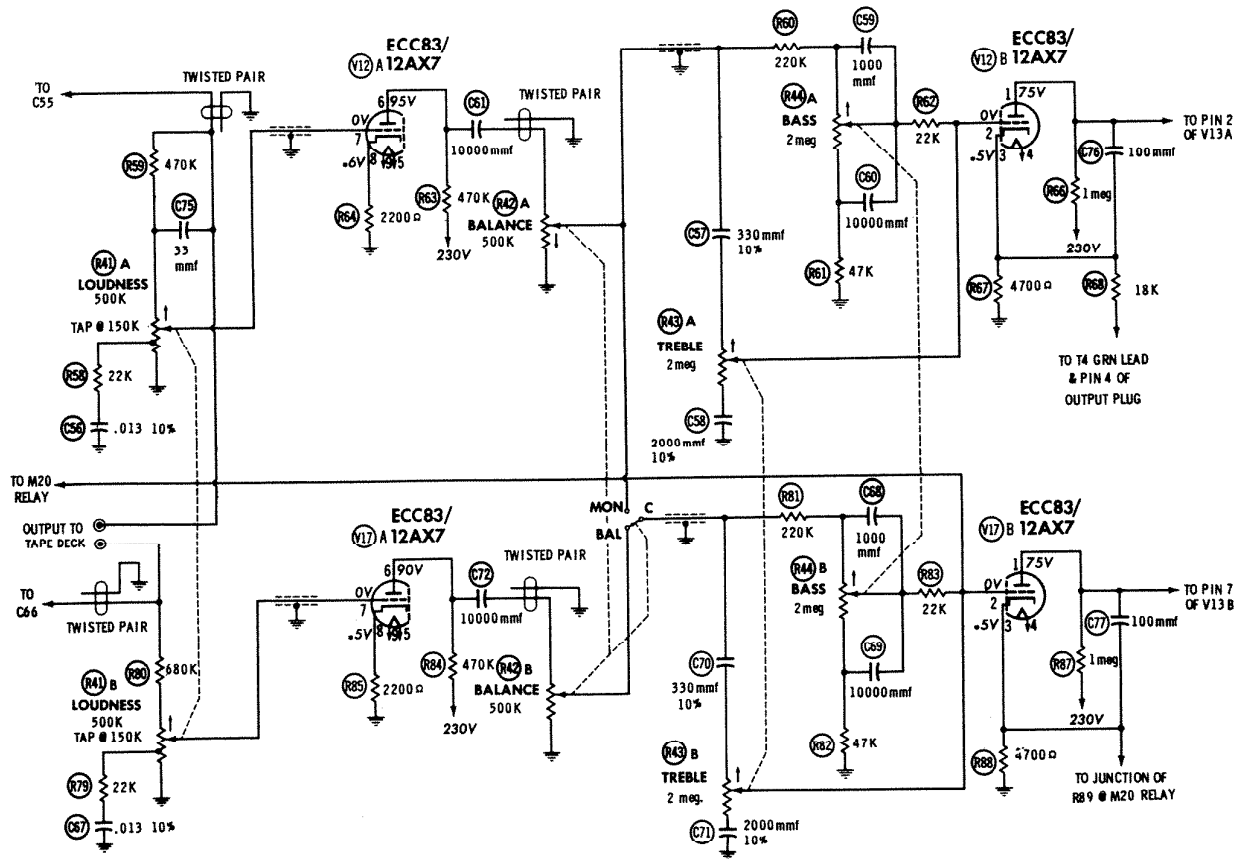

Fig. 1. Partial Schematic of Revised Tone Control Circuit.

AM-FM TUNER CHASSIS—MODEL 2402

Refer to AM-FM tuner schematic on pages 17 and 18 of Service Manual. Capacitor C37 should read 20000 mmf.

Capacitor C35 in the AM-FM tuner parts list on page 22 should read as follows:

C35 10000 mmf, +80%-20%, Ceramic Disc

The color code on the power transformer (T1) secondary windings is shown incorrectly. Refer to Fig. 2 for correct color code.

AM-FM STEREO TUNER—MODEL N-2402

The switching and output circuitry in the Model N-2402 AM-FM Stereo Tuner differs from the Model 2402 AM-FM Tuner as shown in Fig. 2. The following parts have been changed or added:

Ref. No.	Part No.	Description
C15		15 mmf, $\pm 10\%$, NPO, Disc Ceramic
C80		100 mmf, $\pm 10\%$, Mica
R15		68 Ω , 1/2 Watt, Carbon
R130		8200 Ω , 1/2 Watt, Carbon
R131		4700 Ω , 1/2 Watt, Carbon
R132	34022	Level Control, 250K Dual
R133		22K, 1/2 Watt, Carbon
R134		22K, 1/2 Watt, Carbon
R135		22K, 1 Watt, Carbon
R136		10K, 1 Watt, Carbon
R137		10K, 1 Watt, Carbon
L20	30037	Filter
M26	31410	Multiplex Power Socket, 5 Pin
	40216	Dial Glass

Multiplex Adapter Alignment Instructions

A stereo FM signal generator is usually employed for alignment of multiplex circuits. However, as this equipment is not commonly found in most repair shops, the following procedure utilizing standard test equipment is recommended:

TEST EQUIPMENT REQUIREMENTS

VTVM

Oscilloscope

Audio Generator Capable of 67KC generation.
Standard hex and slotted type alignment tools.

ALIGNMENT PROCEDURE:

1. Remove the multiplex chassis from the tuner chassis.
2. Remove the cover from the multiplex chassis in order to gain access to the internal components.
3. Allow the multiplex adapter to warm up for approximately 30 minutes.
4. Ground pin 7 of V21 to disable oscillator L22.
5. Set the audio oscillator to 67KC at about 1.5 to 2.0 volts output, and connect to the multiplex input. Connect the scope to the junction of diodes X1 and X2 and observe the 67KC signal. Adjust trap L21 for minimum 67KC.
6. Connect a carefully tuned 19KC signal from audio generator to horizontal/external sync input of scope and synchronize.
7. Unground pin 7 of V21 and connect vertical input of scope to this point. Switch scope to internal sync and adjust 19KC oscillator L22 until scope is stable. (Scope should indicate same number of cycles observed in Step #6.)

8. Connect the scope to terminal 3 of L23 and adjust L23 for maximum.
9. Coils L24 and L25 are preset and should not be adjusted. The slugs of these coils should be turned all the way in.
10. The 19KC oscillator L22 may have to be slightly readjusted when a stereo program is actually being heard in order for oscillator L22 to be in phase with the 19KC pilot signal from the station.

NOTE: Out of phase setting will be indicated by background whistle—adjust for null. It is preferable to use stereo headphones (high or low impedance) for this adjustment. Connect Hi-Z phones to output of tuner. Connect Lo-Z phones to output of 2401 amplifier. (Red and blue terminals—refer to 2401-2402 service manual.)

Adjustment of Filter L20 (on tuner chassis)

Disconnect filter at junction of R15. Connect 67KC audio generator signal to filter at this point. Connect scope to multiplex output jack and adjust L20 for minimum indication.

Operation and Separation Check

1. Set off-on switch of amplifier and tuner units to "ON" position.
2. Set remote station selector switches to "ON" (down) position. Turn loudness control clockwise to desired listening level. Adjust balance control to balance amplification from Channel A & B speakers. (Check speaker volume controls for proper balance.) Adjust bass and treble controls for desired tone.
3. Set Channel A & B selector switches of tuner to FM Stereo position.
4. Tune in FM stereo broadcast.

NOTE: Check with broadcast station that stereo programming is being transmitted. Do not rely on schedules.

5. The amount of separation in a stereo program will be dependent on the broadcast source material used and local signal conditions. An outside FM antenna is recommended in weak or reflected signal areas. The separation ability of the multiplex unit can best be judged only when a signal is being transmitted on one channel. Many stereo broadcast stations operate in this manner at periodic intervals for test purposes. Separation can also be best observed by use of stereo headphones (See note following Step 10 in Alignment Procedure.)

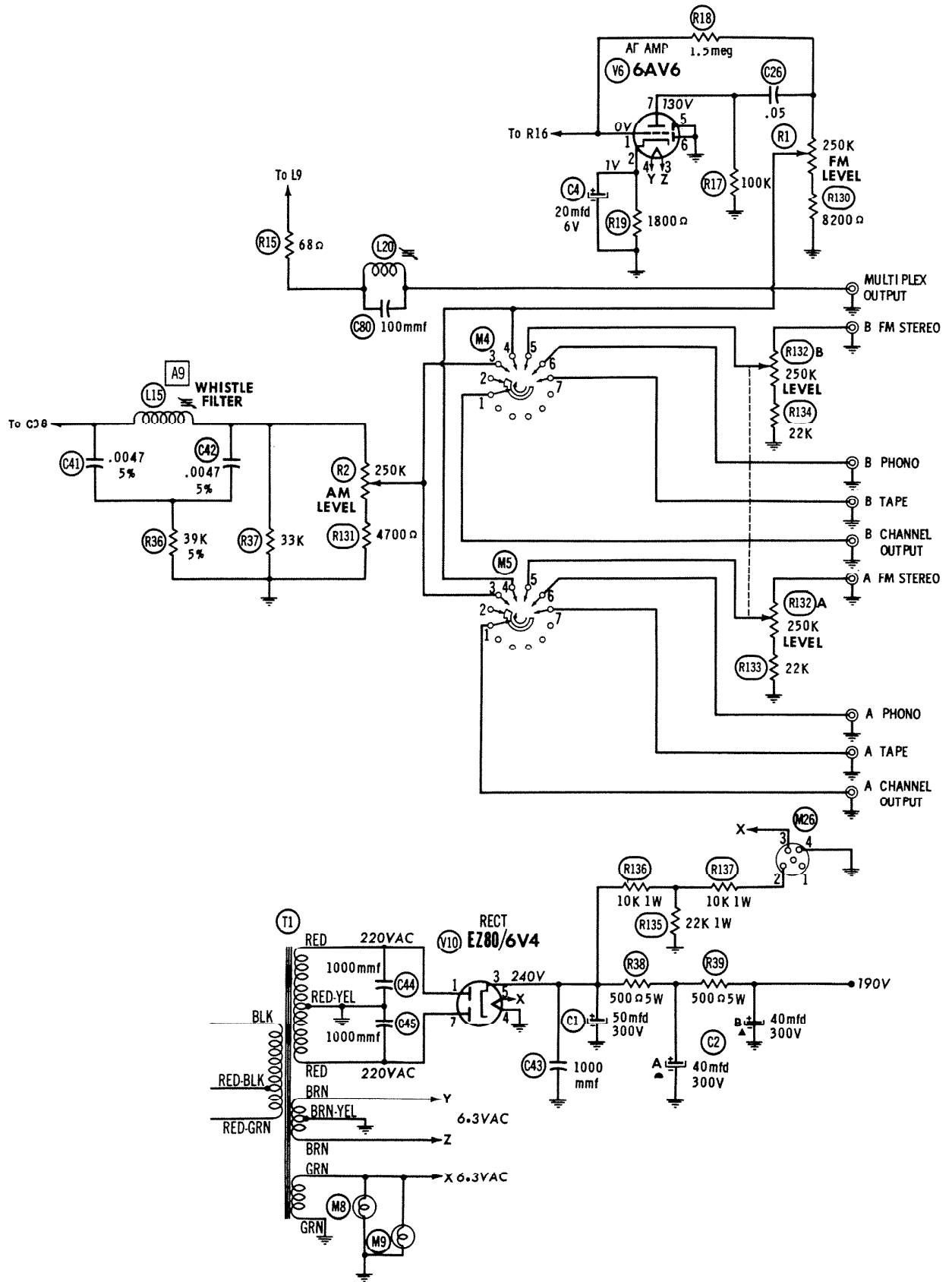
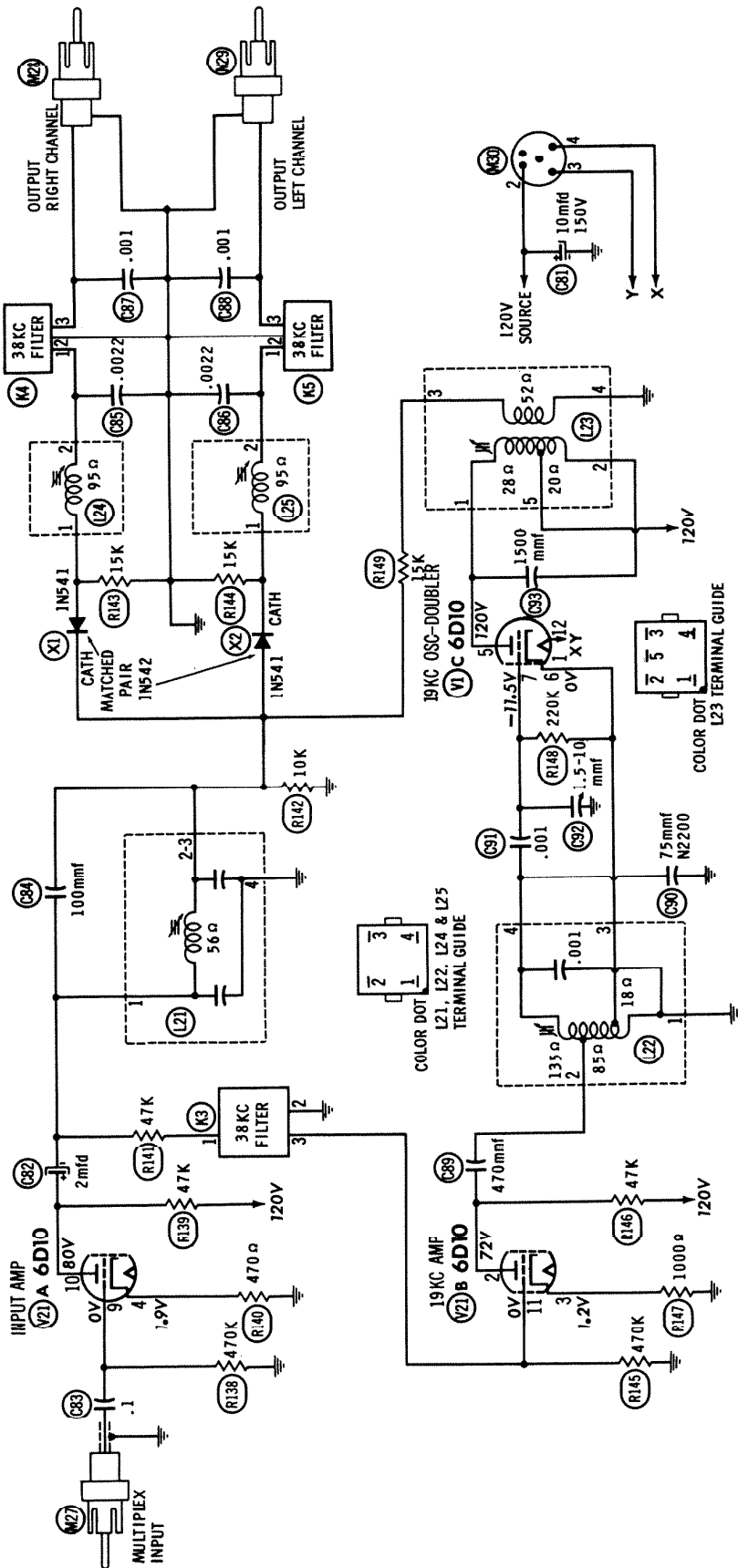

Fig. 2. Partial Schematic of Switching and Output Circuit of Model N2402 AM-FM Stereo Tuner.



RESISTANCE READINGS

ITEM	TUBE	Pin 1	Pin 2	Pin 3	Pin 4	Pin 5	Pin 6	Pin 7	Pin 8	Pin 9	Pin 10	Pin 11	Pin 12
V1	6D10	FIL	*47K	1000Ω	2200Ω	*28Ω	110K	TP	220K	470K	*47K	180K	FIL

- * MEASURED FROM 120V SOURCE. (MXA-1)
 - † MEASURED FROM PIN 3 OF V2. (MXP-2)
 - TP TIE POINT
 - NC NO CONNECTION
 - 1 THIS READING WILL VARY DEPENDING UPON THE CONDITION OF THE ELECTROLYTIC CAPACITORS IN THE CIRCUIT.
1. DC voltage measurements taken with vacuum tube voltmeter;
 2. AC voltages measured with 1000 ohm per volt voltmeter.
 3. Socket connections are shown as bottom views.
 4. Measured values are from socket pin to common ground.
 5. Line voltage maintained at 117 volts for voltage readings.
 6. Nominal tolerance of component values makes possible a variation of ±15% in voltage and resistance readings.

Fig. 3. Schematic of Multiplex Adapter.

Adjustment of Volume Controls for Proper Intercom Gain

Output volume controls for AM (R2), FM (R1), and FM stereo (R132AB) have been relocated on bottom of Tuner Chassis for easy access. (See Fig. 4). Volume controls are pre-set at factory, but variations of signal strength in different areas may require re-adjustment to insure proper intercom gain. Adjust controls as follows:

1. Set amplifier loudness control to #2 position.
2. Set channel selectors on FM STEREO and tune in local FM station—Adjust FM stereo volume control to normal listening level.

NOTE: (This doesn't have to be a stereo program for this adjustment.)

3. Using the same FM station, set channel selectors to FM and adjust blue FM volume control to the same level as FM stereo volume.
4. Set channel selectors to AM and tune in local AM

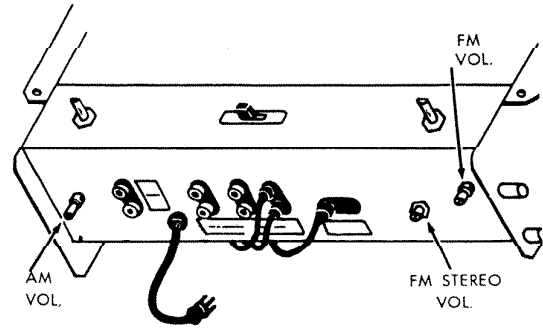

Fig. 4. Location of Volume Controls on Tuner Chassis.

station. Adjust blue AM volume control to FM stereo volume.

MULTIPLEX ADAPTER PARTS LIST

Ref. No.	Part No.	Description	Ref. No.	Part No.	Description
TUBES			RESISTORS (Cont'd)		
V21		6D10, Amp. & Osc.	R147		1000Ω, ½ Watt, Carbon
CAPACITORS			R148		220K, ½ Watt, Carbon
C81	35115	10 mfd @ 150V, Electrolytic	R149		15K, ½ Watt, Carbon
C82	35116	2 mfd @ 150V, Electrolytic	DIODES		
C83		.1 mfd @ 100V, Ceramic Disc	X1	36544	1N542 (Matched Pair of 1N541's)
C84		100 mmf ±10%, Mica	X2		
C85		.0022 mfd ±10%, Ceramic Disc	COILS		
C86		.0022 mfd ±10%, Ceramic Disc	L21	30041	Trap, 67KC
C87		.001 mfd ±10%, Ceramic Disc	L22	30039	Oscillator, 19KC
C88		.001 mfd ±10%, Ceramic Disc	L23	30038	Doubler, 38KC
C89		470 mmf ±10%, Mica	L24	30040	Filter, 76KC
C90		75 mmf, N2200, Ceramic Disc	L25	30040	Filter, 76KC
C91		.001 mfd ±10%, Mica	COMPONENT COMBINATIONS		
C92	35117	1.5-10 mmf, Trimmer	K3	31416	Filter, 38KC
C93		1500 mmf ±10%, Mica	K4	31417	Filter, 38KC
RESISTORS			K5	31417	Filter, 38KC
R138		470K, ½ Watt, Carbon	MISCELLANEOUS		
R139		47K, ½ Watt, Carbon	M27	40212	Phono Plug Ass'y., Multiplex Input
R140		470Ω, ½ Watt, Carbon	M28		Phono Plug, Output
R141		47K, ½ Watt, Carbon	M29		Phono Plug, Output
R142		10K, ½ Watt, Carbon	M30	31414	Power Plug, 5-Pin
R143		15K, ½ Watt, Carbon		31413	Tube Socket, 12-Pin
R144		15K, ½ Watt, Carbon			
R145		470K, ½ Watt, Carbon			
R146		47K, ½ Watt, Carbon			