

SERVICE MANUAL

NUTONE MODEL IM-303

3-WIRE
Built-in Centralized Radio/Intercom System



Product specifications subject to change without notice.

NuTone

Madison and Red Bank Roads, Cincinnati, Ohio 45227
Printed in U.S.A. Rev. 3/89, Part No. 46646-000

CONTENTS	PAGE
INSTALLATION	3
INSTALLATION BLOCK WIRING DIAGRAM	3
OPERATIONAL CHECKOUT	
Master Unit	4
Muting	5
Intercom Operation	5
IS-37 Inside 5 In. Speaker/Clock Timer	6
Background Music	7
THEORY OF OPERATION	
Power Supply	7
Radio Module	8
Audio Controls: Inputs and Outputs	9
AM/FM ALIGNMENT CHART	10/11
Audio Amplifier	12
Control Module & Intercom Switching	12
Terminal Board	14
SERVICING THE IM-303 SYSTEM	
General	15
Removing Master Unit From Its Wall Mounting	16
FIELD REPLACEABLE PC MODULES	Centerfold 17/18
AMPLIFIER/POWER SUPPLY PC BOARD	Centerfold 19
VOLTAGE CHART	Centerfold 20
SCHEMATIC DIAGRAM	Centerfold 21/22
IM-303 SYSTEM INTERCOM SWITCHING & CONTROL	Centerfold 23/24
In The Field Terminal Board Replacement	25
In The Field Control Module Replacement	26
In The Field Tuner Module Replacement	26
Removing Tuner/Amplifier Assembly From Master Unit Housing	26
Replacing Pilot Lights	28
Replacement of I/P And Door Talk Listen Switches	28
Bench Checking The Master Unit	28
SYSTEM TROUBLESHOOTING CHART	28
ADDENDUM	
Muting Circuit Modification	30
DC Power Supply Modifications	30
New PC Boards (Amplifier/Power Supply)	32
R. F. Interference	32
Setting of F.M. Squelch Control R315	34
REPLACEMENT PARTS LIST	35

INSTALLATION

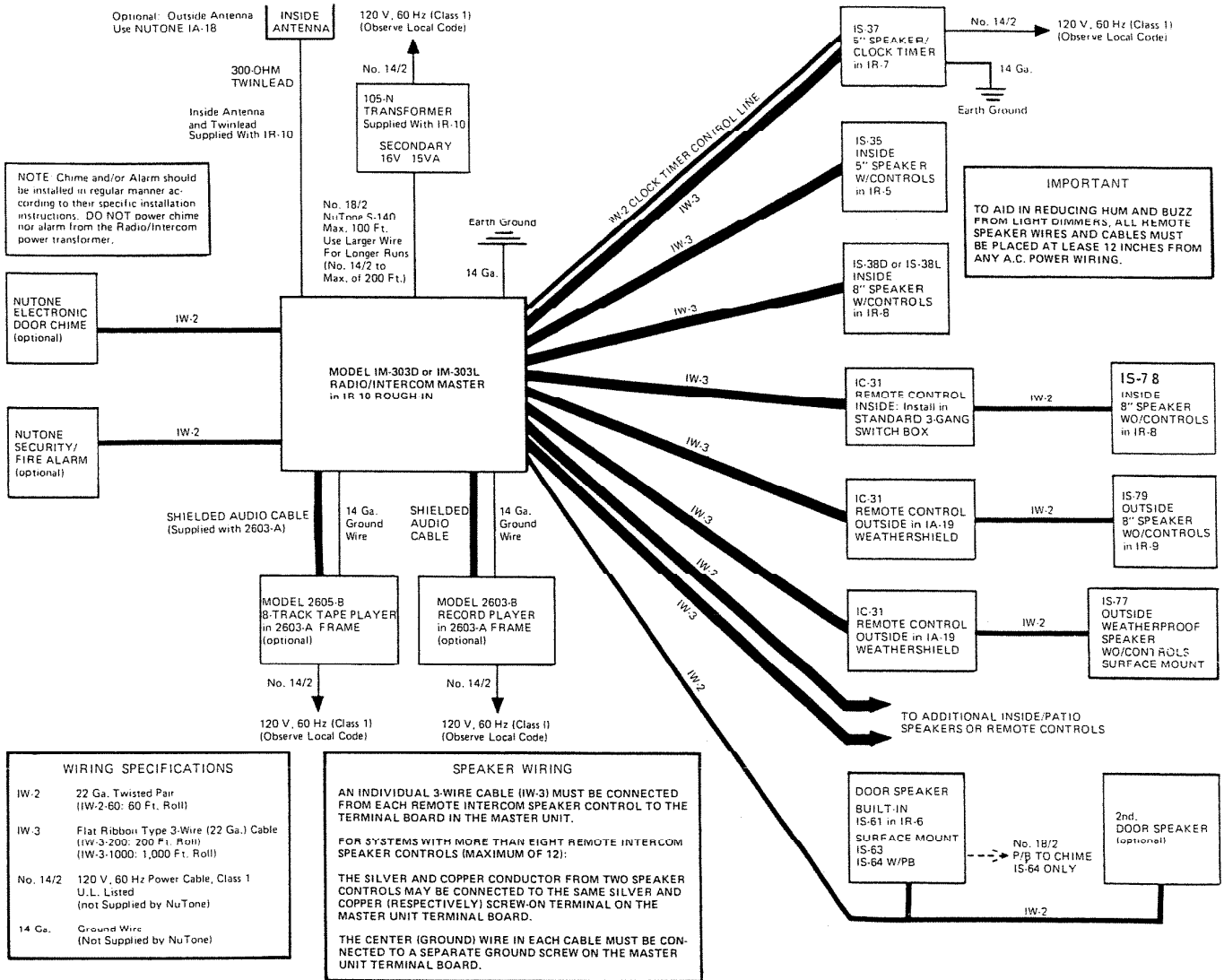

FIGURE 1: IM-303 SYSTEM INSTALLATION BLOCK WIRING DIAGRAM

- (1) All NuTone components are supplied with detailed instructions and should be installed as directed.
- (2) The system must be installed according to the SYSTEM BLOCK WIRING DIAGRAM, Figure 1. The recommended NuTone wire and cable (or engineering equivalent) must be used.
- (3) The Inside Patio (I/P) Speakers; Door Speaker(s); and when used, the Electronic Chime and/or Alarm should be connected to the Master Unit's Terminal Board as shown in Figure 2.
- (4) NOTE: EACH REMOTE INTERCOM I/P SPEAKER CONTROL MUST BE INDIVIDUALLY CONNECTED TO THE MASTER UNIT — USING THE RECOMMENDED NUTONE FLAT RIBBON-TYPE 3-WIRE CABLE (IW-3-200 OR IW-3-1000).

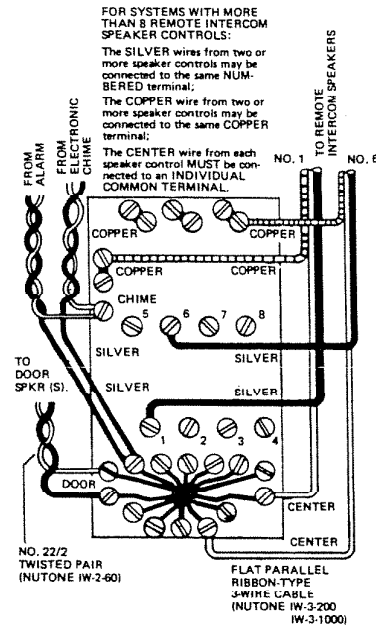

FIGURE 2: TERMINAL BOARD CONNECTIONS

OPERATIONAL CHECKOUT

THE SYSTEM MUST BE CAPABLE OF COMPLETING THE ENTIRE CHECK-OUT PROCEDURE. FAILURE TO COMPLETE ANY STEP INDICATES A MALFUNCTION IN PARTS(s) OF THE SYSTEM.

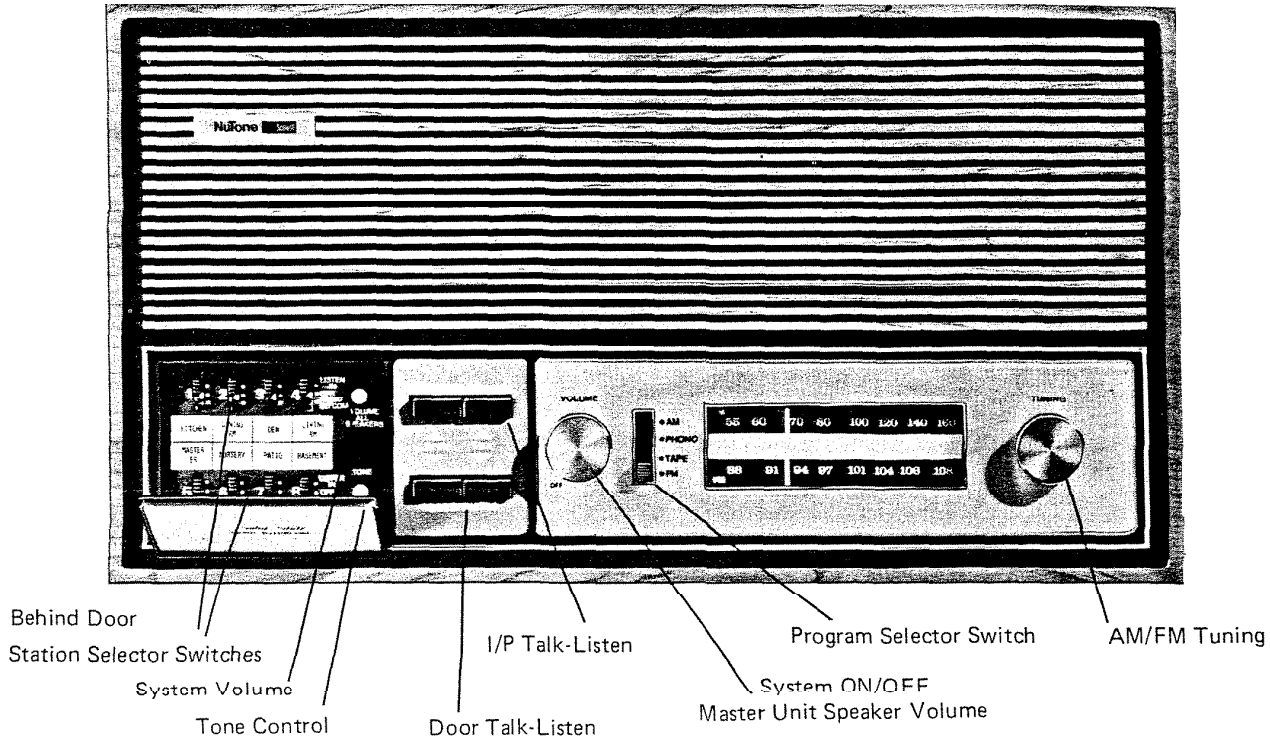

FIGURE 3: IM-303 MASTER UNIT

ON THE MASTER UNIT (Figure 3)

- (1) The TUNING KNOB; ON/OFF-MASTER VOLUME CONTROL (controls volume of Master Unit Speaker only); PROGRAM SELECTOR SWITCH; and I/P and DOOR, TALK/LISTEN CONTROL SWITCHES are located on the front panel.
- (1.1) The STATION SELECTOR SWITCHES (these switches control the operating mode of the Inside/Patio Speakers only); ALL SPEAKER VOLUME CONTROL; and TONE CONTROL are located behind the door at the lower left corner of the front panel. To open door, pull down.
- (2) Turn Master Unit ON: Rotate the ON/OFF-MASTER VOLUME CONTROL clockwise — pilot lights should be turned ON.
- (3) Set PROGRAM SELECTOR SWITCH to AM or FM.
- (4) Using TUNING KNOB, tune radio to a familiar station.
- (5) Open door and set all STATION SELECTOR SWITCHES to RADIO INTERCOM position.
- (6) The MASTER SPEAKER VOLUME CONTROL and the VOLUME CONTROL at every Inside/Patio Speaker Control should be set for maximum volume, i.e. full clockwise
- (7) Adjust the ALL SPEAKER VOLUME CONTROL (behind the door) for sufficient loudness at all locations. The volume in the area requiring the greatest sound level should be sufficient for that locale.
- (8) Adjust the MASTER SPEAKER VOLUME CONTROL and the VOLUME CONTROL on every I/P Speaker Control to the desired volume for their locales.
- (9) NOTE: If the I/P Speakers' VOLUME CONTROLS are set too low and the ALL SPEAKER VOLUME CONTROL is set too high, distortion will result.
- (10) Adjust TONE CONTROL to personal preference.
- (11) With the PROGRAM SELECTOR SWITCH in AM and FM, in-turn, rotate the TUNING KNOB through the band to check radio reception.
- (12) When record player and/or 8-track tape player is included in system: Use the PROGRAM SELECTOR SWITCH: select the unit being checked and play a record or tape of known quality. See the individual operating instructions that are supplied with these components.

MUTING (See Addendum, Page 30)

- (1) Check the system MUTING by pressing in any TALK or LISTEN switch at the Master Unit or at one of the I/P Speaker controls.
- (2) The entertainment program is immediately silenced when one of the switches is activated.
- (3) When the switch is released, the entertainment program fades back in; to full volume in approximately one-half second.

INTERCOM OPERATION

- (1) Press the Master Unit's INSIDE/PATIO TALK SWITCH and talk into the Master Unit speaker. The signal should be heard at every I/P Speaker.
- (2) Press the INSIDE/PATIO LISTEN SWITCH (on Master Unit only). Have another member of the family answer "Hands Free" from any I/P Speaker. (Every I/P Speaker should be checked, in-turn.)

(2.1) NOTE: "HANDS FREE" ANSWERING FROM INSIDE/PATIO SPEAKERS CAN ONLY BE PERFORMED WHEN INTERCOM CALL IS ORIGINATED AT MASTER UNIT, AND ITS INSIDE/PATIO LISTEN SWITCH IS ACTIVATED. ("HANDS FREE" ANSWERING IS NEVER POSSIBLE FROM THE MASTER UNIT.)

- (3) Originate a call from each I/P Speaker, in-turn. Push in the INSIDE/PATIO TALK SWITCH; and talk into the speaker. The call should be heard at the Master Unit and at all other I/P Speakers.

- (4) The call may be answered from any I/P Speaker or from the Master Unit by pushing in the INSIDE/PATIO TALK SWITCH. The answer will be heard at the originating speaker and at all other I/P Speakers and Master Unit Speaker.

- (5) Check Door Speaker(s) operation at Master Unit and at each I/P Speaker, in-turn. Press the DOOR TALK SWITCH to talk to the Door Speaker(s). Press the DOOR LISTEN SWITCH to receive "Hands Free" answer from the Door Speaker(s). All other I/P and Master Unit Speakers will hear the call and the answer.

- (6) Open door on Master Unit and set STATION SELECTOR SWITCH, in-turn, or, two or more at the same time, to OFF.

(6.1) Speakers in this mode cannot receive: entertainment program; chime/alarm signals; nor intercom calls originated by other I/P Speakers or by the Master Unit.

(6.2) Speakers in this OFF mode can originate calls to the Door Speaker(s); and to the I/P and Master Unit Speakers. However, it cannot hear a reply from these speakers. The system will be muted when a TALK or LISTEN switch at the OFF speaker is activated.

- (7) Set the STATION SELECTOR SWITCH for each I/P Speaker to LISTEN IN. (One, two or more I/P Speakers may be operated LISTEN IN at the same time.)

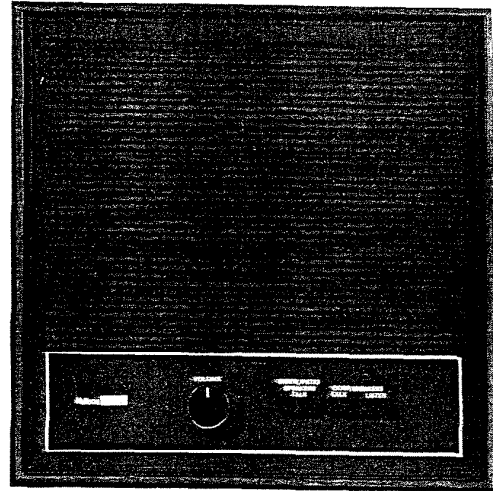

FIGURE 4: IS-38 INSIDE 8-INCH SPEAKER

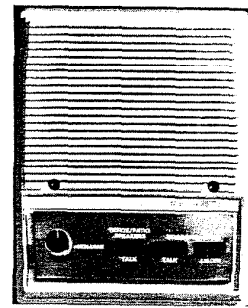
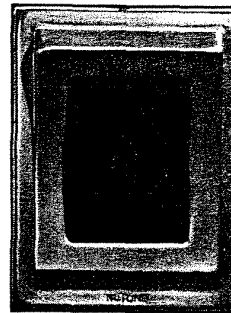
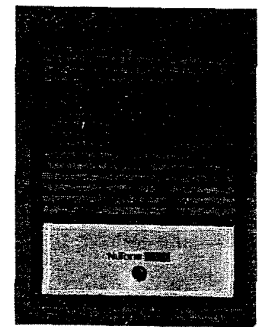

FIGURE 5: IS-35 INSIDE 5-INCH SPEAKER



IS-61



IS-65

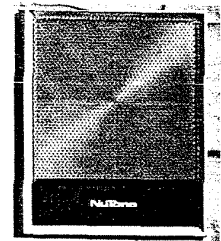

IS-63

FIGURE 6: DOOR SPEAKERS

(7.1) Speaker(s) in this mode will not receive: signals from chime/alarm; intercom signals; nor the entertainment program.

(7.2) Sounds in the locale(s) of the I/P Speakers in this mode will be heard - overriding the entertainment program - at all I/P Speakers that are in RADIO/INTERCOM mode and at the Master Unit.

(7.3) If necessary, to insure "Intercom Override" of the entertainment program, an I/P Speaker in LISTEN IN may have its VOLUME CONTROL set to maximum (full clockwise).

(7.4) If further override is necessary, decrease

the setting of LEVEL SET CONTROL R211 — located on the Amplifier/Power Supply module. This will decrease the amplitude of the entertainment program that is fed to the audio amplifier and thus, increase the intercom signal to entertainment program ratio. The level of both signals may be readjusted with the ALL SPEAKER VOLUME CONTROL (behind door).

(8) The Master Unit speaker is not controlled by a STATION SELECTOR SWITCH. It operates the same as Inside/Patio Speakers that are in RADIO/INTERCOM mode. It can be turned OFF by turning the MASTER UNIT SPEAKER VOLUME CONTROL to full counter-clockwise position, but not past "Click."

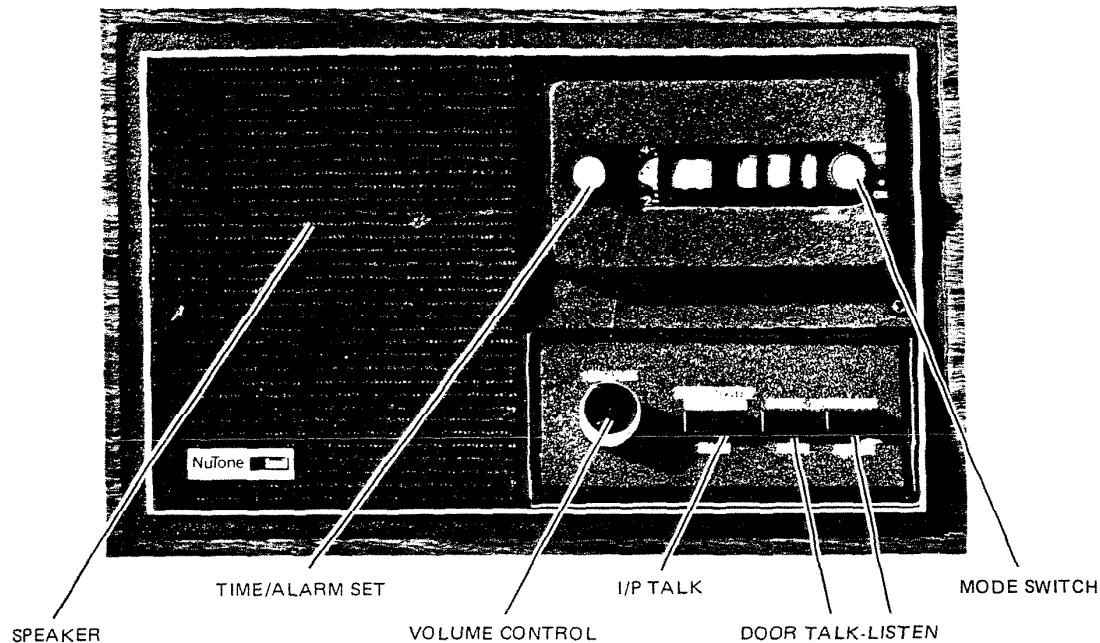

FIGURE 7: IS-37 INSIDE 5-INCH SPEAKER/CLOCK TIMER

IS-37 INSIDE 5-INCH SPEAKER/CLOCK TIMER

(1) Operation of the VOLUME CONTROL and TALK-LISTEN SWITCHES is the same as that for the other I/P Speakers.

(2) MODE SWITCH:

(2.1) OFF: Entertainment program muted through entire system. Intercom operation normal, as determined by the setting of its STATION SELECTOR SWITCH in the Master Unit.

(2.2) ON: Full normal operation, determined by the setting of its STATION SELECTOR SWITCH.

(2.3) AUTO: Entertainment program muted. Normal intercom operation. This setting used to automatically turn ON the entertainment program at a predetermined time.

(2.4) ALARM: Same as AUTO operation except when the entertainment program is resumed, the alarm buzzer in the IS-37 will be turned ON and will continue to sound until the MODE switch is thrown to ON (or OFF).

(2.5) TIME/ALARM SET CONTROL: Rotate control clockwise (the alarm dial will turn counter-clockwise) to the time desired for the entertainment program to resume.

(2.5.1) When the clock has advanced to the desired time, (as set in (2.5) above) muting of the entertainment program will be removed, and the music will resume through all speakers that are in RADIO/INTERCOM mode. (If the MODE SWITCH is set to ALARM, the alarm buzzer will also be sounded.)

(2.5.2) For continuous normal radio/intercom operation, the mode switch should be returned to the ON position.

(2.5.3) Clock should advance approximately 40 minutes before resetting to AUTO or ALARM position.

(3) SETTING CLOCK TO CORRECT TIME: Push in the TIME/ALARM SET CONTROL and turn - in either direction - until the clock is reading the correct time.

BACKGROUND MUSIC (See Addendum, Page 30)

(1) The IM-303 Master Unit may be used to supply the music program source for speakers that will reproduce the entertainment program only.

(1.1) THE IM-303 IS DESIGNED FOR USE WITH THE NUTONE MODEL IM-516 AUDIO AMPLIFIER.

(1.2) WHEN USED WITH AMPLIFIERS OTHER THAN THE IM-516, CONTACT NUTONE'S FIELD ENGINEERING DEPARTMENT.

(2) During intercom operation, the entertainment program will be muted at the I/P and Master Unit Speakers. The intercom signals will not be heard through the "Music Only" speakers.

(2.1) EXCEPTION: Since there is no muting in the system when chime/alarm signals and signals from I/P Speakers in LISTEN IN mode are being sent through the system, these signals will be heard through the background music speakers.

(3) **CONNECTING THE IM-303 TO THE IM-516:**
(See IM-516 Installation Instructions)

(3.1) IM-516 WITHIN SIX-FEET OF IM-303 Connect a No. 22/2 twisted-pair (NuTone IW-2-60) between the BLUE/BLACK "LOW LEVEL RADIO OUTPUT" wires in the IM-303 and the "LOW LEVEL RADIO INPUT" wires in the IM-516. The color-coded wires should be connected to the matching color coded wires in the IM-516.

(3.2) IM-516 MORE THAN 6-FEET FROM IM 303: (Maximum of 50-feet), use a shielded audio cable between the units. Connect the shield between the BLACK wires and the center conductor between the BLUE wires.

(4) The IM-303 is normally operated with the OVERRIDE CONTROL R211 set to *maximum*. To prevent muting of the background music program during intercom operation, turn the control 10 to 15 degrees off maximum.

(5) Adjust the IM-516's LEVEL SET CONTROL R6 for the desired volume at the background music speakers.

(6) After adjusting the IM-303 OVERRIDE CONTROL, it may be necessary to readjust the Master Unit's ALL SPEAKER VOLUME CONTROL, and in some cases, the MASTER UNIT SPEAKER VOLUME CONTROL and the VOLUME CONTROLS on the individual I/P Speakers.

CHIME/ALARM OPERATION

(1) Press the chime pushbutton at entrance, the chime signal should be heard through the Master Unit Speaker and through all I/P Speakers that are in RADIO/INTERCOM mode.

(2) Check the alarm system (see individual operating instructions supplied with the individual alarm systems), the alarm signal should be heard through the Master Unit Speaker and through all I/P Speakers that are in RADIO/INTERCOM mode.

THEORY OF OPERATION (See Center Fold for Schematic Diagram, Wiring Diagram and PC Boards)

POWER SUPPLY (See Addendum, Page 30)

(1) The Power Transformer (NuTone Model 105-N) is supplied with the IR-10 rough-in housing and should be located remote from the Master Unit — near power panel, etc.

(2) The 105-N is rated at 120Vac, 60 Hz. primary input and at 16Vac, 15 VA secondary output.

(3) The secondary of the power transformer may be connected to the Master Unit by 100 feet (maximum) of No. 18/2 cable (NuTone S-141). For runs up to 200 feet, use No. 14/2 cable (not supplied by NuTone).

(4) Terminal 2 of J4 should be connected to earth ground.

(5) The 16Vac is turned ON (or OFF) by the ON/OFF SWITCH S101 (operated by the shaft of the Master Unit Speaker Volume Control R101).

(6) When S101 is ON, the 16Vac is applied to the series circuit of PL103; R108; PL102; R109 and PL103. R108 and R109 limit current through the lamps.

(7) The 16Vac is applied to Z201 (Z201 includes D203; D204; D205; and D206) full-wave bridge rectifier. The output of the bridge is filtered by C209 and results in Vcc of +22.5Vdc.

(7.1) Capacitors: C207; C208; and in later production units, C221 and C222 bypass the high frequency switching noise that may be generated by the diode rectifiers.

(8) The +22.5Vdc is connected to the voltage regulator circuit, R235; R239; Q209 and Zener diode D210. R239 limits Q209 collector current. Although Q209 is a heavy duty device, shorting of the Regulated 11.5Vdc must be avoided. The 11.5Vdc powers the AM-FM Radio Module.

(9) The regulated 11.5Vdc is switch by SELECTOR SWITCH S102 to the AM or FM tuner and IFs, and is open ended when in PHONO or TAPE position.

(10) 12Vdc at the junction of Q209 base and cathode of D210 is connected through R237 to supply muting voltage: to the control circuit of IS-37; and through the Inside/Patio LISTEN SWITCH S103 to Q210 when set is bench checked and the Control Module is not installed.

RADIO MODULE

(1) The Radio Module includes the complete AM and FM tuners.

(2) When S102 is in AM position, the regulated +11.5Vdc is fed through P1-2/J1-2 to the AM tuner.

(3) When S102 is in FM position, the regulated +11.5Vdc is fed through P1-3/J1-3 to the FM tuner.

FM TUNER

(1) The FM signal is fed through the coaxial antenna lead-in to the balanced primary of the antenna transformer L301. The transformer primary is center tapped to FM RF ground through C301.

(2) The RF amplifier Q302 (Dual gate MOSFET) is operated tuned-gate, tuned-drain — resulting in high-gain at low noise.

(3) The FM RF signal is fed through a section of the antenna transformer secondary through C304 to G1 of Q301. The gate tuned circuit is varied by tuning one section of the ganged tuning capacitor C303A. C303B is the high-frequency trimmer. Tuning slug in L301 is tuned for low-frequency padding.

(4) The MOSFET drain is loaded by the tuned RF tank circuit. The tank's resonant frequency is varied by C303F. C303E is high-frequency trimmer and L302 is low-frequency padder.

(5) The output of the tank circuit is coupled through C310 to the base of the Mixer Q302.

(6) The oscillator Q303 resonant frequency is tuned by C303J. C328 is high-frequency trimmer and L303 is adjusted for low-frequency padding.

(7) The output of the oscillator is coupled through C327 to the base of Mixer Q302.

(8) The Mixer Q302 beats the RF and oscillator signals and is loaded by T301A tuned to the 10.7 Mhz. IF frequency.

(9) For additional selectivity, the output of T301A is coupled through C314 to T301B.

(10) The output of T301B is coupled from the highside of C315 to the Ceramic Filter CF301.

(11) CF301 is rated at 10.7 Mhz. with a 3 db bandwidth of 200 to 280 KHz. — more than sufficient for the FM broadcast band. The filter has a very high rejection of all other RF frequencies, eliminating the need of additional IF transformer for high-selectivity.

(12) The output of CF301 is fed to terminal 1 of Z301.

(13) Z301 is a monolithic integrated circuit that provides all the functions of a comprehensive FM IF system, including 3-stage FM IF amplifier/limiter with level detector and an audio amplifier that features use of a noise squelch circuit.

(14) The quadrature detector is tuned by the out-board coil L304.

(15) The squelch circuit is adjusted by R315. Use of the squelch circuit helps to eliminate side responses that are characteristic of limiter-discriminator type FM receivers.

(16) Suppression of these side responses permit the design of an FM receiver that tunes as easily as an AM tuner without resorting to AFC — where AFC is not required to correct for oscillator drift.

(17) The FM oscillator in this system has been designed with quality components and with the use of the regulated 11.5Vdc supply should be practically free of drift under normal operating conditions.

(18) The magnitude of the squelch control voltage depends only on the signal-to-noise ratio at the tuner input and is essentially independent of the front-end gain because the quadrature signal is fully limited.

(19) Adjustment of the "Squelch Threshold" control affect primarily the degree of noise suppression rather than the threshold. Control R315 is generally operated at maximum value, i.e. full-clockwise as viewed from the FM side of the Radio Module PC Board. (See Addendum, Page 34)

(20) VR301 protects the FM and AM front end from static discharge and nearby lighting. It will not protect the set from a direct lighting strike.

AM TUNER

(1) The AM signal is fed from the center tap of the FM antenna transformer primary, through R331 to the tuned RF circuit.

(2) The RF circuit is tuned by gang capacitor C303D. C303C is the high-frequency trimmer and coupling of L309 is adjusted for low-frequency padding.

(3) Delayed AGC is supplied from pin 15 of Z302, through R329 and across D301 to ground. When the signal increases beyond desired level, the diode will conduct, changing the impedance of the input circuit and tend to swamp the AM signal.

(4) The output of the tuned RF circuit is fed through C333 to pin 2 of Z302

(5) Z302 is a monolithic integrated circuit providing AM convertor; IF amplifier and detector. In this application it also supplies AGC to the first IF stage and delayed AGC to the RF tuned circuit.

(6) Pin 2 of Z302 is the base of the oscillator/convertor stage.

(7) The oscillator tank is tuned by varying C303G. C303H is the oscillator trimmer and L310 oscillator collector coupling is adjusted for low frequency padding.

(8) The oscillator/converter output is loaded by the 455 KHz. IF transformer T302. The output of T302 is fed through Ceramic Filter CF302 to the input of the first IF stage in the IC Z302.

(9) The amplified output of the first IF stage is fed from Pin 6 through CF303 to the input of the second IF amplifier and second detector.

(10) CF302 and CF303 Ceramic Filters' center frequency is 455 KHz. \pm 2 KHz. with a 3 db bandwidth of 10 KHz. \pm 3 KHz. with a frequency stability within 0.4% from -10°C to $+80^{\circ}\text{C}$.

(11) Use of these filters provides improved selectivity; the elimination of IF transformers and the resulting small space.

(12) C337 is the internal AGC filter.

(13) The recovered audio is fed from the detector output through R326; J1-1/P1-1 and R233 to the AM terminal on S102.

ALIGNMENT (See Page 10/11)

(1) The Master Units are shipped from the factory completely aligned.

(2) Alignment should be performed by qualified personnel **ONLY WHEN ABSOLUTELY NECESSARY**.

(3) Use the alignment method recommended in this manual.

AUDIO CONTROLS: INPUTS AND OUTPUTS

(1) **SELECTOR SWITCH S102**; One side of this switch selects the audio entertainment program that is fed to the audio amplifier.

(1.1) The other side of the switch controls the regulated 11.5Vdc to the AM and FM RF and IF stages — driving the tuner that is being used. When the switch is in PHONO or TAPE, the +11.5Vdc is open ended and, neither the AM nor FM tuner has voltage applied.

(2) The AM program, from P1-1 through R233, is selected when S102 is in number 1 (top) position. The +11.5Vdc is fed to the AM tuner through P1-2.

(3) The PHONOGRAPH signal is fed through PHONO INPUT J104 and is loaded by C103 and R107 to the number 2 position of S102. C103 and R107 supply the correct load for the cartridges used in NuTone record changers.

(4) The TAPE PLAYER signal is fed through TAPE INPUT J105 and is loaded by R106 through the number 3 position of S102. The tape input matches the NuTone Tape Players.

(5) The FM program through P1-4 and R234 is selected when S102 is in the number 4 (bottom) position. The regulated +11.5Vdc is fed to the FM tuner through P1-3.

(6) The common audio terminal of S102 feeds the audio program to the LOW LEVEL RADIO OUTPUT connection, and through C206 to the high side of the 2.2 Megohm LEVEL SET CONTROL R211.

(7) The LOW LEVEL RADIO OUTPUT may be used to drive NuTone's Model 516 background music amplifier. This entertainment program will not be interrupted when the system is being used for intercommunications through the standard speakers (IS-35, IS-38, etc.).

(7.1) The LOW LEVEL RADIO OUTPUT is engineered for use with NuTone's Model 516 Audio Amplifier. When it is to be used to drive other amplifiers, consult NuTone's Field Engineering Department for specific details.

(8) The wiper contact of R211 is fed through R210 and a shielded cable to the TONE CONTROL CIRCUIT C101/R102 and the SYSTEM VOLUME CONTROL R103, and back through another shielded cable; R212; and coupling capacitor C212 to the base of the first audio amplifier Q203.

(8.1) The wiper of R211 is also connected to the collector of the muting transistor Q210. When Q210 is turned ON [Veb(sat)], its collector is effectively at ground potential and the audio on R211's wiper will be shorted out.

(9) When the LOW LEVEL RADIO OUTPUT is used to drive a background music amplifier, R211 should be backed off 10° to 15° from its maximum (normal) setting. This will prevent shorting of the entertainment program at the high-side of R211.

(10) **THE INTERCOM SIGNAL**: from Door Speaker(s); Inside/Patio Speaker(s); Master Unit Speaker, and when used, chime and/or alarm is fed through the intercom input Transformer T201 and C201 to the base of intercom preamp Q201.

(11) T201 has a voltage step-up of 84 and Q201 has a voltage gain of 17. The amplified intercom signal is coupled through R208 — reducing the signal by a factor of 33.

(11.1) Q201's gain is not used. This stage's primary function is to determine the frequency characteristic of the intercom signal and to isolate the input transformer from the first audio amplifier Q203.

(12) The collector of Q202 is connected to the junction of R208; C212 and the audio input from R103. When the positive "Key Click" suppression voltage — from the Control Module — is applied to the base of Q202, it will be turned ON and short the audio signal (that is present on its collector) to ground.

(13) The diodes D201 and D202 protect the secondary of T201 from excessive transient voltages that may be generated during intercom switching.

TUNER ALIGNMENT

This receiver should be aligned ONLY WHEN ABSOLUTELY NECESSARY and ONLY BY QUALIFIED PERSONNEL. Use non-inductive, low-capacity alignment tool when making adjustments.

F. M. ALIGNMENT

MASTER UNIT SETTINGS:

1. SELECTOR SWITCH S102 in FM.
2. ALL SPEAKER VOLUME CONTROL R103 set to desired level.
3. SQUELCH CONTROL R315 (located on Radio Module board) set to minimum (full counter-clockwise position as viewed from F.M. Side of PC board).

INSTRUMENTS REQUIRED:

1. CATHODE RAY OSCILLOSCOPE
 - 1.1 High side of vertical input connected through a 15K ½ watt resistor to tuner's F.M. Audio output, J/P1-4.

NOTE: DO NOT TOUCH THE REGULATED +11.5 Vdc TERMINAL J/P1-3. DO NOT SHORT THE VOLTAGE TO GROUND. SHORTING THE +11.5 Vdc MAY RESULT IN DESTROYING THE VOLTAGE REGULATOR Q209 AND THE 12V ZENER DIODE D213.

- 1.2 Low (ground) side of vertical input connected to Radio Module ground.
- 1.3 Use 60 Hz. horizontal sweep. If scope does not have own 60 Hz. horizontal, use exterior source.

2. FM SIGNAL GENERATOR
 - 2.1 Modulate RF output with 60 Hz. at 400 KHz. sweep width.
 - 2.2 Connect 60 Hz. to scope's horizontal input if required.
 - 2.3 Connect a 50 ohm resistor across RF output of signal generator.
 - 2.4 Connect high-side from generator to center conductor of coax antenna lead-in
 - 2.5 Connect low-side (ground) from signal generator to shield (braid) of coax.

Step	Signal Generator Setting	Receiver Setting	Adjust	Tune For
1.	106 MHz. @ 2 to 5 microvolts. (If generator does not have calibrated output, use lowest level consistent with good trace on scope.)	Tune receiver (ganged tuning capacitor to pick up signal generator).	L304 Quadrature coil. Detune coil to get wave form as shown in "A" below. If wave is negative, reverse direction of slug detuning.	Maximum trace on scope as shown in "A" below. Sacrifice gain for linearity and flat top. If necessary, reduce output from signal generator to prevent receiver limiting.
2.	108.5 MHz.	F.M. Tuning Dial to 108.5 MHz. (Ganged Tuning Capacitor fully opened.)	C328 Oscillator Trimmer	do
		F.M. Tuning Dial to 87.5 MHz. (Ganged Tuning Capacitor fully closed.)	Frequency of RF output from Signal Generator. (Should be in neighborhood of 87.5 MHz.)	do
IF, IN STEP 3 ABOVE, FREQUENCY OF SIGNAL GENERATOR IS VERY CLOSE TO 87.5 MHz				
4(e)	87.5 MHz.	F.M. Tuning Dial to 87.5 MHz. (Ganged tuning Capacitor fully closed.)	L303 Oscillator Coil	do
IF, IN STEP 3 ABOVE, FREQUENCY OF SIGNAL GENERATOR IS BELOW 87.5 MHz. (87 MHz or lower)				
4(b)	Slightly decrease the inductance of L303: Turn tuning slug approximately 1/8 turn counter clockwise. Repeat steps 2 and 3 above.			
IF, IN STEP 3 ABOVE, FREQUENCY OF SIGNAL GENERATOR IS ABOVE 87.5 MHz. (88 MHz. or higher)				
4(c)	Slightly increase the inductance of L303: Turn tuning slug approximately 1/8 turn clockwise. Repeat steps 2 and 3 above.			
5.	Repeat 2 and 3 above until oscillator is rocked in at both ends of dial.			
6.	106 MHz.	F.M. Tuning Dial to 106 MHz.	C303B RF Input Transformer 303E RF Output Trimmer T301A and T301B, Mixer 10.7 MHz. IF Output.	do
7.	90 MHz.	F.M. Tuning Dial to 90 MHz.	L301 Antenna Input Transformer: Two peaks may be noted while adjusting this slug. USE THE PEAK WITH THE SLUG POSITIONED NEAR THE BOTTOM OF THE COIL. L302 RF Amplifier Tank Coil	do
8.	Repeat steps 6 and 7 until no further improvement in scope trace is noted at either setting. As the set is aligned, it may be necessary to reduce output of Signal Generator to prevent receiver limiting.			
9.	90 MHz. @ 10 microvolts. (If uncalibrated, use sufficient signal strength to drive receiver into limiting.	F.M. Tuning Dial to 90 MHz.	L304 Quadrature Coil.	Maximum symmetrical "S" curve. See "B" below. Curve should be linear and equal distance above and below the reference line on scope.
10.	Step 9 should be checked for various frequencies across the F.M. band. Check limiting by increasing the output of the signal generator, the "S" curve's amplitude should remain the same.			
Disconnect signal generator and (if used) external sweep to scope. Scope should use regular horizontal sweep. Tune receiver between stations. Note noise at J/P1-4 (as seen on scope). Turn R315 full clockwise for maximum squelch. Noise should disappear and straight line horizontal trace be seen on scope.				

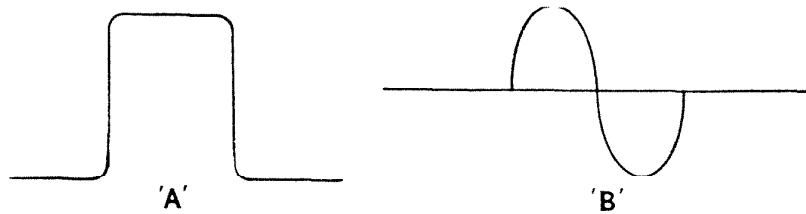

A. M. ALIGNMENT

MASTER UNIT SETTINGS:

1. SELECTOR SWITCH S102 in AM.
2. ALL SPEAKER VOLUME CONTROL R103 set to desired level.

INSTRUMENTS REQUIRED:

1. CATHODE RAY OSCILLOSCOPE

- 1.1 High side of vertical input connected through a 15K ½ watt resistor to tuner's A.M. Audio output. J/P-1.

NOTE: DO NOT TOUCH THE REGULATED +11.5 Vdc TERMINAL J/P1-2. DO NOT SHORT THE VOLTAGE TO GROUND. SHORTING THE +11.5 Vdc MAY RESULT IN DESTROYING THE VOLTAGE REGULATOR Q209 AND THE 12V ZENER DIODE D213.

- 1.2 Low (ground) side of vertical input connected to Radio Module ground.

- 1.3 VTVM may be used but, recommend Oscilloscope so that linearity as well as amplitude of the audio signal may be observed.

2. AM SIGNAL GENERATOR

- 2.1 Modulate RF output with 400 Hz. @ 30%.

- 2.2 Connect high-side of generator output through 200 pf. (ceramic or mica) capacitor to shield (braid) of coax antenna lead-in.

- 2.3 Connect low-side (ground) of generator output to Radio Module ground.

Step	Signal Generator Setting	Receiver Setting	Adjust	Tune For
1.	537 KHz. Use signal level required. Do not overdrive.	AM Tuning Dial to 537 KHz. (Ganged Tuning Capacitor fully closed)	L310 Oscillator Padder Coil*	Maximum sine wave trace on scope. (or maxi-voltage on VTVM)
2.	1620 KHz.	AM Tuning Dial to 1600 KHz. (Ganged Tuning Capacitor fully opened)	C303H Oscillator Trimmer	do
3.	Repeat steps 1 and 2 until no further improvement can be made and oscillator tunes at both ends.			
4.	600 KHz.	AM Tuning Dial Set to 600 KHz.	L309 AM Antenna Transformer	do
5.	1500 KHz.	AM Tuning Dial Set to 1500 KHz.	C303C Antenna Tuning Trimmer	do
6.	Repeat steps 1 and 2 until no further improvement can be made and RF tuning tracks across the band.			
7.	1500 KHz.	AM Tuning Dial Set to 1500 KHz.	T302 AM IF (455 KHz.) Transformer	do

(*) May be tuned to two peaks: One peak with slug at top of coil and other peak with slug near bottom of coil. Recommend use of peak with slug near bottom of coil.

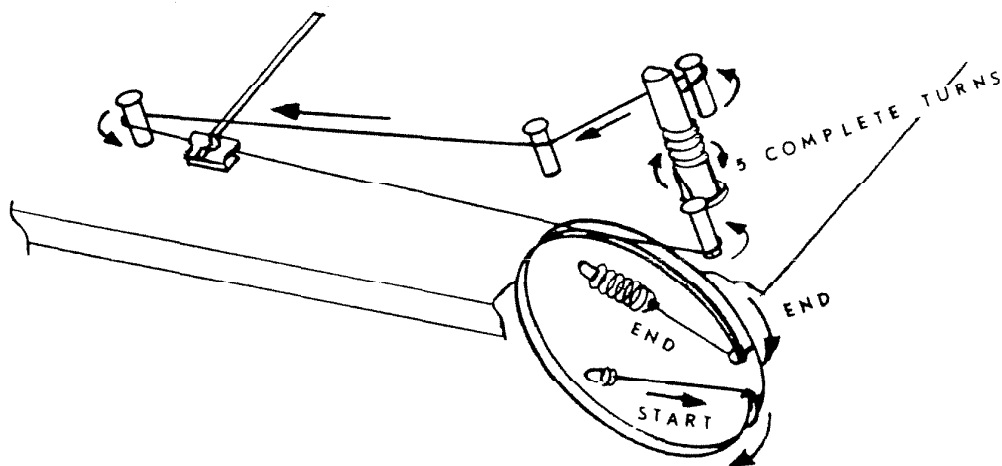

DIAL CORD INSTALLATION

(1) The amplifier is powered by the +22.5Vdc supply (Vcc).

(2) The audio signal(s) from the intercom pre-amp Q201 and/or the volume control R103 is fed through C212 to the base of the first audio voltage amplifier Q203. This stage has a gain of 7. Its output is direct coupled to the base of Q204, the second audio amplifier.

(3) The second audio amplifier operates with no gain, in fact, the signal is reduced approximately 20% through the stage. It has a very high input impedance and its dynamic characteristic is very important in determining AC and DC feedback; and in conjunction with C214 the high-frequency response of the amplifier.

(4) The output of Q204 is direct-coupled to the Darlington connected amplifier-driver Q205 and Q206. This Darlington combination has a gain of 270. The no signal collector current of Q205/Q206 generates a slight forward bias to the power output transistors Q207 and Q208.

(4.1) This bias is generated across D207 and R226. D207 is a temperature tracking diode mounted on the amplifier's heat sink.

(5) With the slight forward bias on Q207 and Q208, they are operated Class AB complimentary. The AB operation helps eliminate notch crossover distortion in the output stages. Q207 and Q208 have a very high current (power) gain. They are mounted on the heat sink.

(6) If the output transistors draw extra current — resulting in greater heat dissipation through the heat sink — D207's cathode to anode voltage decreases. With the decrease in diode voltage drop, the forward bias on Q207 and Q208 decreases, resulting in a decrease in collector current, thus, tending to stabilize the operating condition of the output transistors.

(7) To overcome the high input impedance of Q208, the bootstrapping capacitor C218 is coupled from its output to the junction of R228 and R229.

(8) The Amplified Audio Output is coupled through C219 to the load. The circuit is protected against shorts on the speaker side of C219 by the diodes D208 and D209 which under short circuit conditions, limit the current through Q207. Q208 is protected by its high input impedance.

(9) AC degeneration is coupled through R224 to the emitter of Q204.

(10) The overall gain of the amplifier — Q204 through Q207/Q208 — is controlled by the ratio of the resistance of R224/R222. The gain is approximately 183. If R222 is shorted, the gain should increase by a factor of 24.

(10.1) It may be desirable when servicing some types of trouble to short R222 and observe the signal at various points without the influence of negative feedback.

(11) DC STABILITY: R216 and R218; and R217 form a voltage divider from Vcc to ground and the base of Q204. Q204 base bias voltage is approximately one-half Vcc.

(12) When Q204 collector current increases, Q205/Q206 bias current increases and results in an increase of collector current.

(13) As Q205/Q206 collector current increases the collector voltage rises to near Ve (Vcc). This increases the forward bias on Q207 and Q208.

(14) When forward bias on Q207 and Q208 is increased, their collector currents are increased and the voltage at the junction of their emitter resistors R232 & R231 goes toward Vcc.

(15) This junction voltage is fed through R224 to the emitter of Q204, as this voltage increases Q204's forward bias is decreased and the collector current decreases. If the output center voltage rises above Q204's base voltage, Q204 will be turned OFF, thus reversing the action of para (11) - (14) above.

(16) If the output center voltage should attempt to stabilize much below the base bias on Q204, Q204 will conduct harder and force the center point voltage to rise.

(17) Unless there is a failure of component(s), the 100% DC feedback will lock the DC operating voltages at their designed values.

(18) EXAMPLE: Q206 develops an emitter-collector short. The base voltage of Q207 would be equal to Vcc and the emitter voltage about the same (the increased positive voltage on the base of Q208 would tend to clamp it off). The very high voltage at the junction of R231 and R232 will be fed back to the emitter of Q204, and even though Q204's base remained clamped on one-half of Vcc, the high voltage (approximately full Vcc) fed to the emitter would reverse bias Q204 and keep it turned OFF.

CONTROL MODULE & INTERCOM SWITCHING

FOR THE FOLLOWING DISCUSSION, SEE THE SCHEMATIC DIAGRAM AND THE JM-303 SYSTEM INTERCOM SWITCHING & CONTROL DIAGRAM

(1) The Control Module is powered by the 22.5Vdc supply (Vcc) that is fed through J/P2-2 from the Amplifier/Power Supply Module.

(2) The Quad Amplifier Integrated Circuit Z401 is operated as four individual voltage comparators: Z401A; Z401B; Z401C; and Z401D. They control the intercom switching operation.

(3) A positive (+) reference voltage is applied to the positive (+) input terminal of each comparator. These potentials are derived from the voltage divider network: R404; R403; R402; and R401 (all part of resistor pack Z403). The actual voltages on the positive terminals of the comparators will be somewhat less than those measured at the divider resistor terminals. The 1 Megohm resistors: R408—R414 limit the input current of their respective comparator:

The resistor pack voltages:

Terminal 5	14.5V
Terminal 6	9.4V
Terminal 7	3.9V
Terminal 4	17.5V (Control Line Point "X")

(4) The CONTROL LINE'S normal voltage, i.e. when no intercom function is being used, is +17.5V. This voltage is connected to the negative (-) terminals of the comparator amplifiers (through 1 Meg resistors), keeping them clamped OFF.

(5) When the DOOR LISTEN switch in an I/P Speaker is activated, point "X" is connected through R502 and D505, and then through the originating I/P Speaker Control's R2 (8.2K) and common to INPUT GROUND. The voltage at point "X" goes to 9.9V; Z401A is turned ON and its terminal 9 goes to 13.5V. The other three comparators remain OFF.

(5.1) The 13.5V from terminal 9 is fed through D408 to the base of Q402. The diode D411 between base and emitter keeps a reverse bias on Q402 and it is clamped OFF. The voltage charges C404 and this charging voltage is fed through D412 to point "W". The voltage at "W" is fed through J/P2-3 to the base of KEY CLICK SUPPRESSION transistor Q202, turning it ON. When Q202 is turned ON, the collector goes to approximate ground (emitter potential), and the audio on Q201's collector and that on Q203's base will be shorted out.

(5.2) This voltage appears at "W" only during the charging time through C404, and keeps Q202 turned ON for approximately 150 milliseconds. This is sufficient to eliminate most of the switching noises, allowing just enough "Click" to keep the operator aware that intercom switching is taking place.

(5.2.1) When the Door Listen switch is released, the voltage through D408 and D411 is eliminated, and the capacitor C404 discharges through the now forward biased Q402. This discharging voltage is coupled to Q202's base and suppresses "Key Clicks" when switch is opened.

(5.2.2) The KEY CLICK SUPPRESSION VOLTAGE can be measured at J/P2-3. On a standard 20K ohm/volt multimeter, and it will read between .25 and .35 volts. The actual voltage as seen on a scope will be approximately .8 volts @ 150 to 200 millisecond pulse width.

(5.3) The 13.5V from terminal 9 will also be fed through R419 and D407 to "U". The voltage "U" is fed through J/P2-5 and D211 to the base of Q210, turning it ON. When Q210 is ON, its collector is at ground and the entertainment program is MUTED. This voltage will remain on "U" while the DOOR LISTEN switch is held closed. This voltage is .7 on Q210 base and 1.4 at J/P2-5.

(5.4) When the switch is released, the voltage at "U" will decay at an RC rate and the voltage on Q210's base will fall through saturation to turn OFF, and the entertainment program will fade-back, in something less than 1/2 second.

(5.5) The 13.5V from Z401A terminal 9 is also fed through R418 and the Audio Switching diode D410; then through J/P2-6 and Input Transformer T201 to INPUT GROUND.

(5.6) When D410 is turned ON, the DOOR SPEAKER LINE'S audio, coupled through normal contacts of K401 and C403; superimposed on the forward biased D410 to the Intercom Input Transformer T201. The audio signal from the Door Speaker will be amplified and heard by the Master Unit speaker and all I/P Speakers that are in RADIO/INTERCOM mode.

(5.6.1) (NOTE) The I/P Speakers mode of operation is controlled by the Station Selector Switches: S501—S508, located on the Terminal Board in the Master Unit.

(5.7) When the DOOR LISTEN switch is released, D410 is turned OFF and an audio signal that may be picked up by the Door Speaker(s) will be blocked from the Input Transformer T201.

(6) When the DOOR TALK switch in an I/P Speaker is activated, point "X" is connected through R502 and D505; through R1 and the speaker voice coil; and through common to INPUT GROUND. The voltage at "X" goes to approximately 5V. Z401B and Z401D are turned ON. Quad comparator terminal 4 goes to 11.3V and terminal 10 goes to 11.3V.

(6.1) The 11.5V from terminal 4 is fed through D404 to terminal 8 keeping Z401A turned OFF. Voltage at "X" is still too high positive to allow Z401C to be turned ON.

(6.2) The 11.5V at terminal 4 is also fed through R417 to the base of Q401, turning it ON which activates DOOR RELAY K401, which now connects the high side of the Door Speaker(s) through the relay contacts and J/P2-4 to the Audio Output. The other side of the Door Speakers will be connected through common to OUTPUT GROUND.

(6.3) The 11.5V at terminal 10 is fed through D409 to the MUTING and KEY CLICK SUPPRESSION circuits. These circuits operate as described in (5) above.

(6.4) The 11.5V from terminal 10 is also fed through R416; J/P2-9 and to Audio Switching diode D501 — turning it ON. Talking into the originating I/P Speaker, will result in the audio signal bypassing R1 through C1; through the turned on diode D501; J/P3-1; J/P2-9; C402; and J/P2-6 to the high side of T201. The common from the originating I/P Speaker is connected to the INPUT GROUND.

(6.5) Both the Door Speaker and I/P audio signal will be heard at all other I/P Speakers when they are in RADIO/INTERCOM mode, and at the Master Unit Speaker.

(7) When the I/P TALK switch in an I/P Speaker is activated, point "X" is connected through R502 and D505; through the I/P TALK switch and the speaker voice coil; and then through common to the INPUT GROUND. The voltage at "X" goes to 2 volts and Z401C and Z401D are turned ON. The voltage at Z401 terminal 5 goes to 13.5 and at terminal 10 goes to 13.

(7.1) The 13.5 volts from terminal 5 is fed through D402 to the negative (-) terminal of Z401B and through D404 to the negative terminal of Z401A, keeping these amplifiers clamped OFF.

(7.2) D403 and D401 are blocking diodes, keeping the controlled voltages from the ON sections of the quad comparator from the Control Line.

(7.3) The 13 volts from terminal 10 is fed through D409 to the MUTING and KEY CLICK circuit as described in (6.3) and (5) above. It is also fed to D501 turning it ON.

(7.4) The audio signal from the originating speaker is fed through the SILVER and CENTER (INPUT and COMMON) leads and through the turned on D501 to the Intercom Input Transformer T201.

(7.5) Audio signals sent from the I/P Speaker will be heard at all other IP Speakers in RADIO/INTERCOM mode and through the Master Unit Speaker.

(8) The Master Unit's DOOR LISTEN: DOOR TALK: and I/P TALK operations are the same as for an I/P Speaker, EXCEPT: Its control line is fed through control diode D508; and its "Talk" path is through Audio Switching diode D504.

(9) The Master Unit Speaker is always in RADIO/INTERCOM mode. It can be silenced both for talking and listening by turning its volume control R101 to minimum (full counter-clockwise). Do Not turn past "Click" except when turning entire system OFF.

(10) MASTER UNIT INSIDE LISTEN: When S103 is activated, all I/P Speakers that are in RADIO/INTERCOM mode will have one side (OUTPUT SILVER) connected through J/P3-7; one side of S103; J/P3-5 to Audio Switching diode D504 and the I/P TALK INPUT LINE; J/P2-9; C402; and J/P2-6 to the high side of T201.

(10.1) D504 is turned ON by the CONTROL LINE being connected through R502 and D508; J/P3-5; S103; J/P3-7; out the SILVER lead to the I/P Speakers and then through common to INPUT GROUND. This causes point "X" to go to approximately 2 volts-turning ON Z401C and Z401D. (S103 in effect acts as an I/P TALK switch in the I/P Speakers. The I/P Speaker(s) will now talk back through the INPUT, SILVER wire through S103.

(10.2) The MUTING and KEY CLICK SUPPRESSION acts the same as in any other intercom function.

(10.3) The Master Unit Speaker remains connected between audio output and OUTPUT GROUND.

(10.4) If the Control Module is removed from the chassis, the MUTING operation can be checked by depressing S103. The MUTING LINE (B) will be connected through S103 to the base of Q210-silencing the entertainment program.

(10.5) When S21 in the IS-37 Clock Timer Control is closed the MUTING LINE (B) voltage will be connected to base of Q210.

TERMINAL BOARD (See Schematic Diagram)

(1) Provides convenient connecting points for wires and cables from auxiliary equipment.

(1.1) CHIME/ALARM INPUT: One wire to this terminal and other wire to one of the COMMON terminals. The high side is connected through isolating resistor R501; and J/P3-3 to the high side of T201. The common side is connected to INPUT GROUND.

(1.2) DOOR SPEAKER: One side to DOOR terminal and other side to one of the COMMON terminals. The high side is connected through J/P3-6; and J/P2-7 to the common terminal of DOOR RELAY K401. The common side is connected to INPUT GROUND or OUTPUT GROUND, depending on its operation.

(1.2.1) Two or three Door Speaker(s) may be connected to the DOOR terminal and the same COMMON terminal. All Door Speakers are operated in the same mode at any one instant.

(1.3) I/P SPEAKERS: Maximum of 12 I/P Speaker Controls may be connected in the system.

(1.3.1) EACH I/P SPEAKER CONTROL'S COMMON (CENTER) CONDUCTOR MUST BE CONNECTED TO AN INDIVIDUAL COMMON TERMINAL.

(1.3.2) The OUTPUT (SILVER) conductor from each I/P Control should be connected to an individually

numbered OUTPUT (SILVER) terminal. In systems with more than 8 I/P Controls, the SILVER leads from two I/P Controls may be connected to the same OUTPUT terminal. Speakers connected to the same terminal will be operated in the same mode as determined by the setting of the corresponding Station Selector Switch (S501—S508).

(1.3.3) The INPUT (COPPER) wire from each I/P Control should be connected to an individual INPUT terminal.

(1.3.4) When four or less I/P Controls are used, connect the COPPER wires to only one of each pair of COPPER terminals. Divide the load.

(1.3.5) When more than eight I/P Controls are used, connect the COPPER wire from two I/P Controls to the same terminal, again dividing the load.

(2) STATION SELECTOR SWITCHES S501—S508: Control the operating mode of the I/P Speakers connected to the corresponding OUTPUT terminal.

(2.1) Position 1, LISTEN IN: Connects the I/P Speaker's OUTPUT (SILVER) wire through J/P3-3 to the high side of T201. The common side will be connected to INPUT GROUND.

(2.1.1) Any sounds in the vicinity of speaker(s) in this mode will be amplified through the system and will be heard by the Master Unit speaker; and by

(12) Treat all printed circuit boards with care. Do not burn or mutilate when making or breaking solder connections. Be extremely careful of the foil paths. Use solder-sucker type iron when removing components from the board. Do not over-

heat diodes and transistors.

(13) When replacing twisted-pair interconnecting wires, make certain that the replacement pairs are twisted in same manner.

REMOVING MASTER UNIT FROM ITS WALL MOUNTING

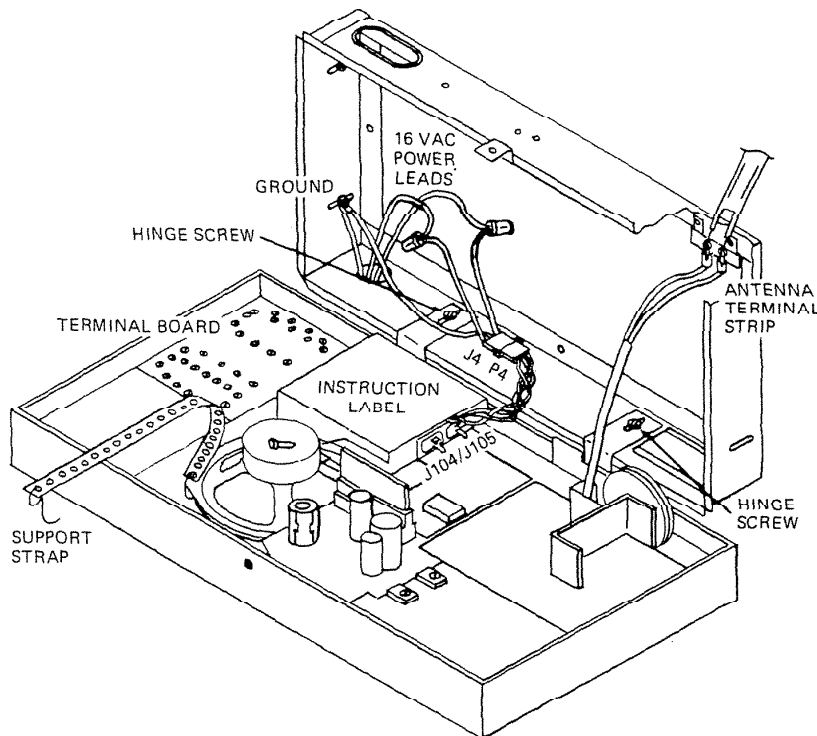

IM-303 INSTALLED IN IR-10
FIGURE 8

(1) Disconnect: Power plug P4 from J4; and tuner's coax antenna lead from antenna terminal board. (Figure 8)

(2) If the following optional equipment is included in system:

(2.1) Phonograph and/or auxiliary Tape Player: Disconnect their shielded leads from J104 and/or J105.

(2.2) IS-37 Speaker/Clock Timer: Disconnect the Protection circuit J31 from P31.

(2.3) Background Music Amplifier: Disconnect the Blue and Black "Low Level Output" wires from the audio line (twisted-pair or shielded cable) that is feeding the background music amplifier.

(3) REMOVING MASTER UNIT WITHOUT DISCONNECTING THE INTERCONNECTING WIRES AT THE TERMINAL BOARD. (Omit step (4) below)

(3.1) Complete steps (1) through (2.3) above.

(3.2) Disconnect the Terminal Board from Amplifier/Power Supply Module, i.e. P3 from J3.

(3.3) Remove the four Terminal Board Phillips head mounting screws and lift terminal board, with

the interconnecting wires and cables intact, out of cabinet. Carefully stow the Terminal Board and attached wires in the rough-in housing.

(4) REMOVING THE MASTER UNIT COMPLETE WITH THE TERMINAL BOARD. (Omit step (3) above.)

(4.1) Complete steps (1) through (2.3) above.

(4.2) Remove the I/P Speaker Controls' flat three-wire ribbon type cables from their respective terminals. Each cable should be marked so that the Output (Silver) wires can be reconnected to their respective terminals.

(4.3) Remove the Door Speaker wires and the Chime/Alarm wiring from their respective terminals. Label these wires so that they will be reconnected to their proper terminals.

(4.4) The Terminal Board must be removed when the Station Selector Switches; Diodes; Resistors; Voltage Regulator Lights; or the P3/Wire assembly are to be repaired or replaced.

(4.5) NOTE: WHEN THE TERMINAL BOARD IS NOT CONNECTED TO THE AMPLIFIER/POWER SUPPLY CHASSIS (P3 to J3) THE ENTERTAIN-

(To Page 25)

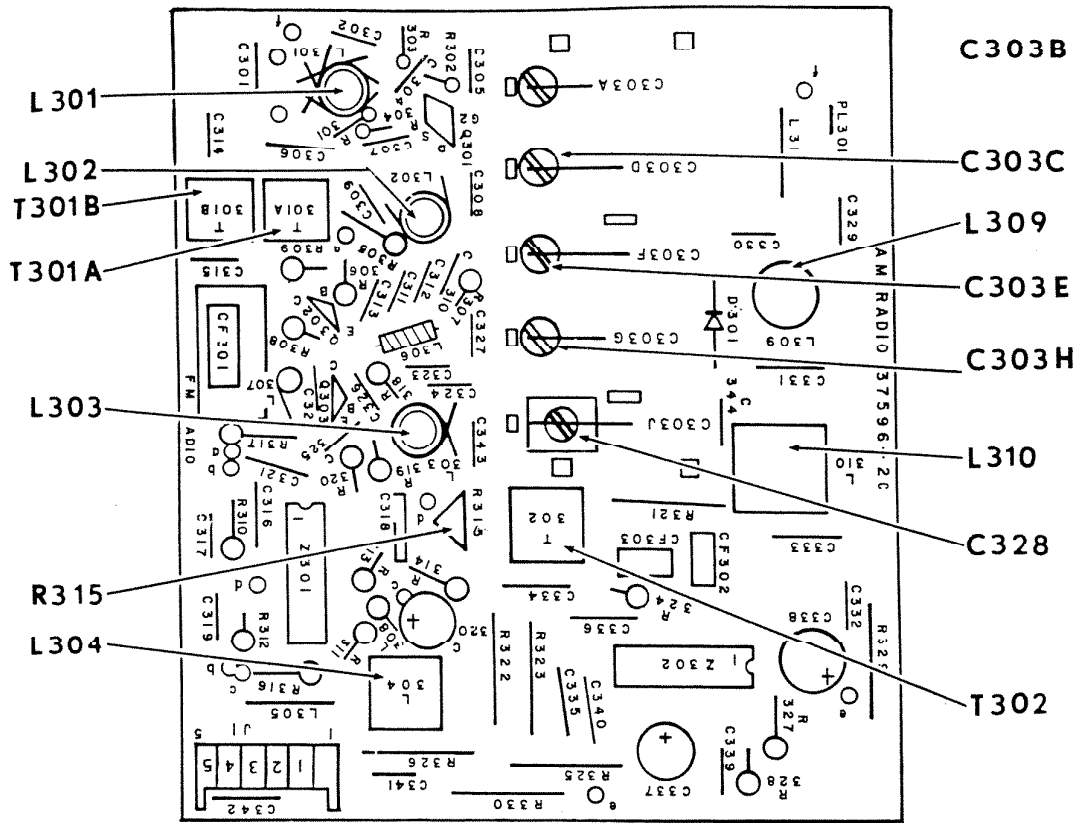

AM/FM TUNER MODULE COMPONENT LOCATION

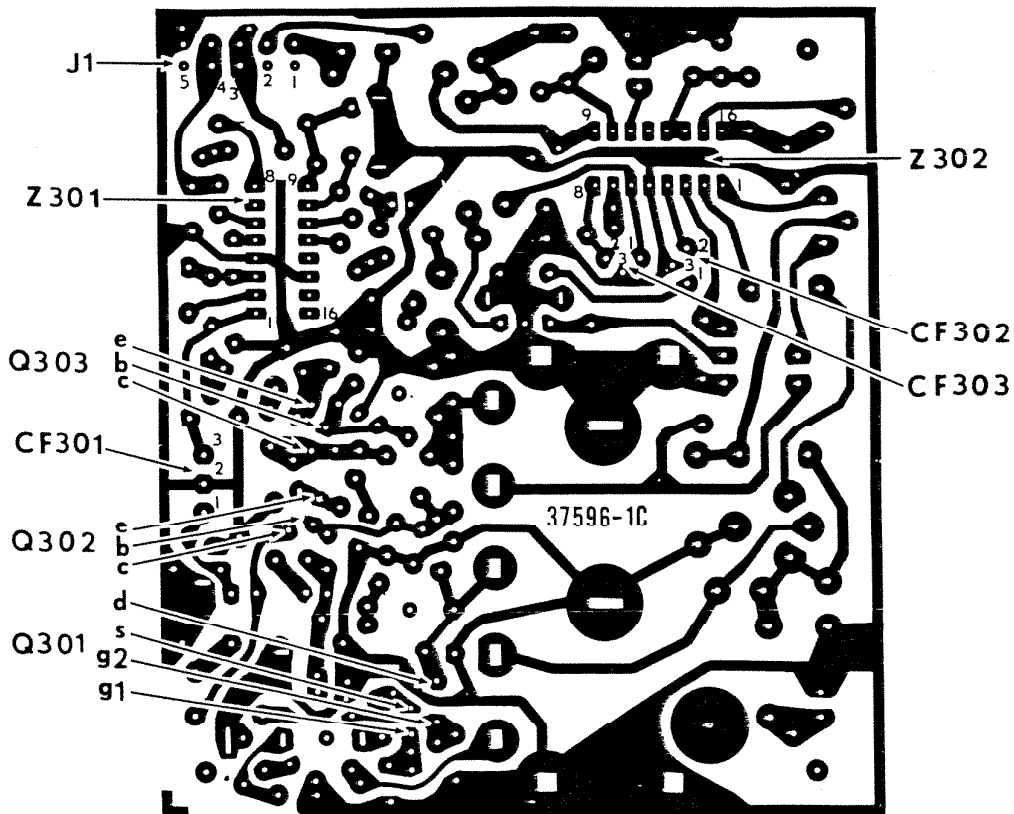

AM/FM TUNER MODULE FOIL PATTERN

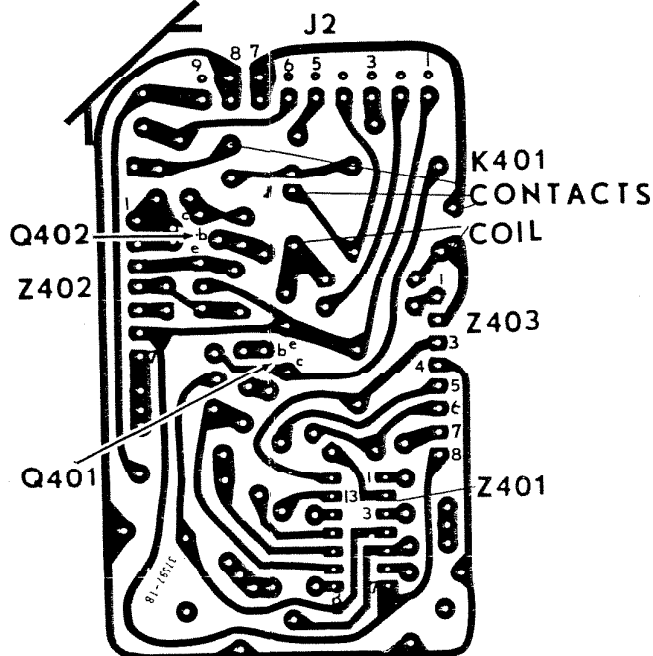
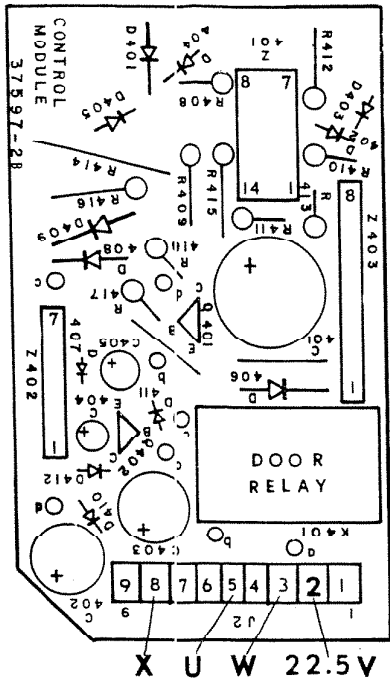
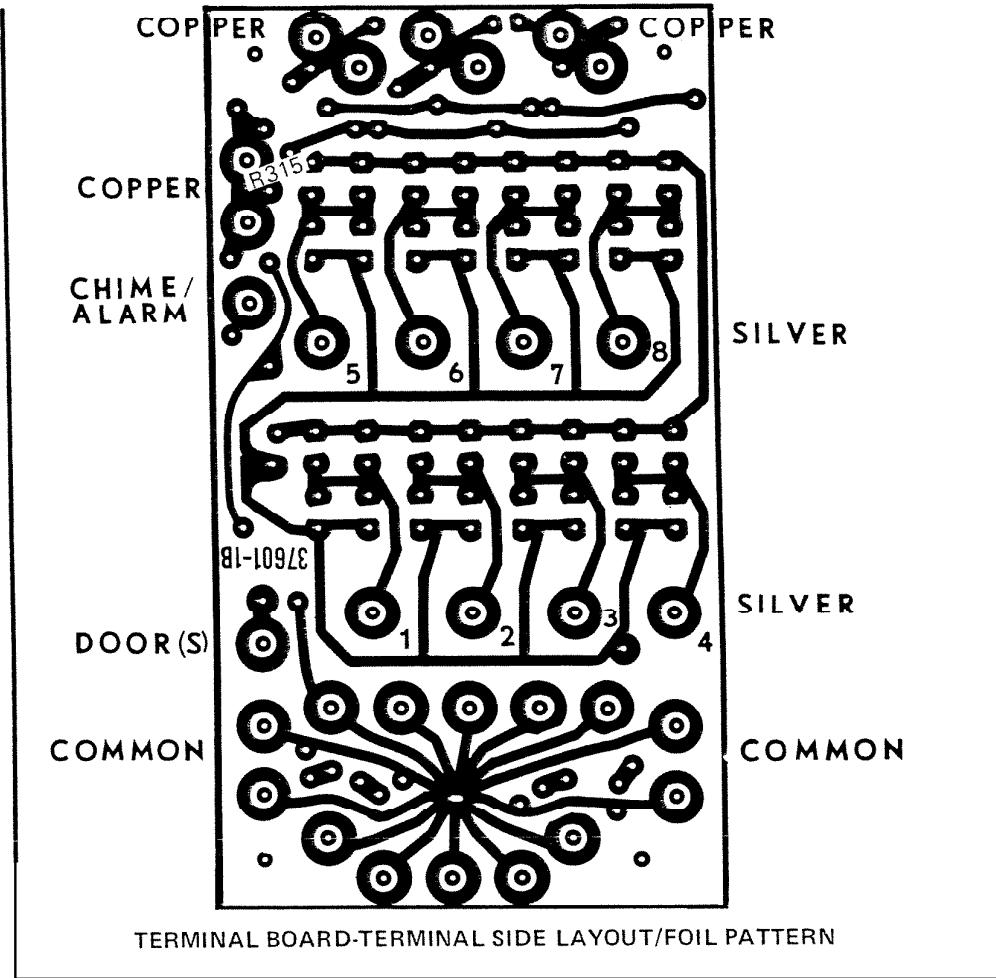

CONTROL MODULE COMPONENT LOCATION

FIELD REPLACEABLE PC MODULES
(Original Production Units)

CONTROL MODULE FOIL PATTERN

FIGURE 9

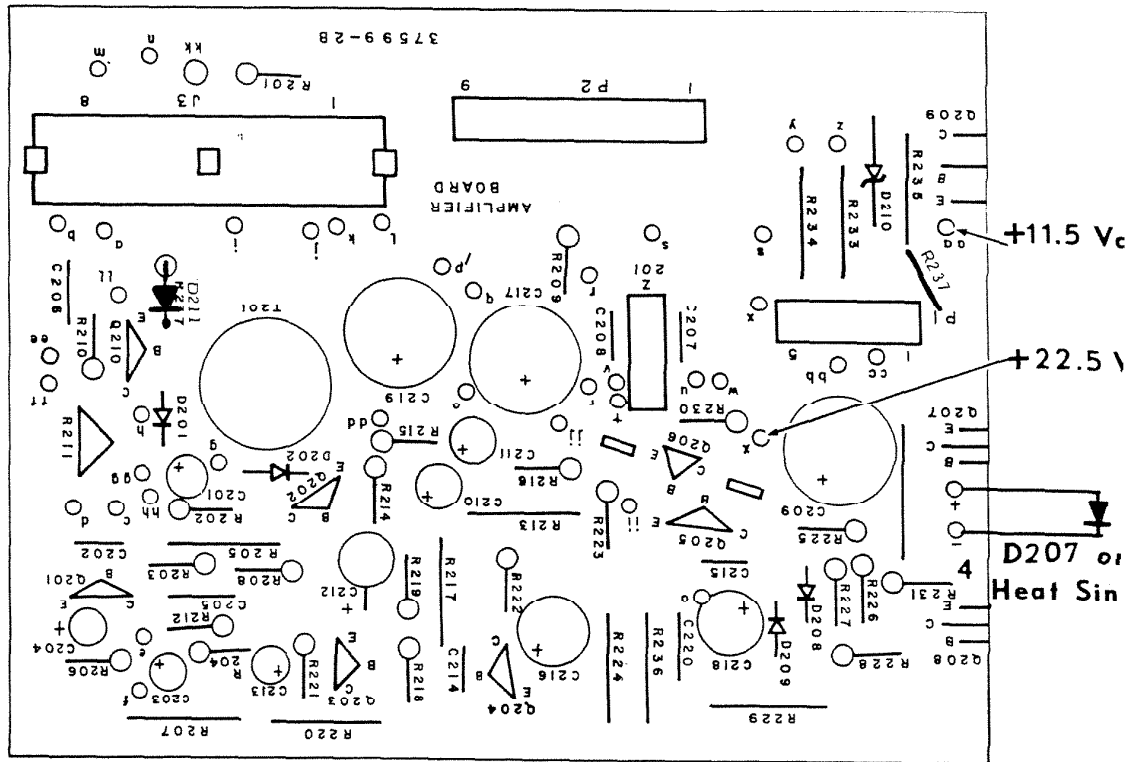

AMPLIFIER/POWER SUPPLY MODULE COMPONENT LOCATION

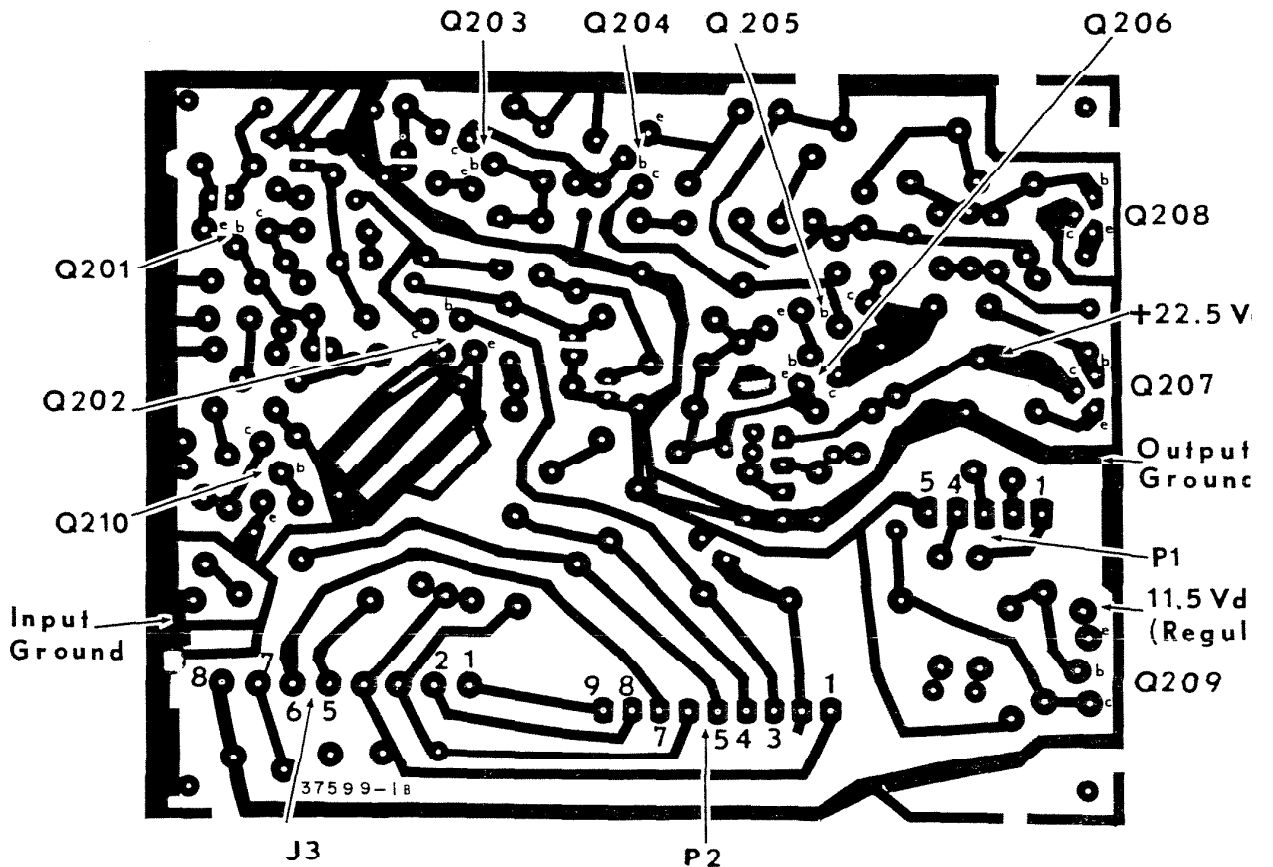

AMPLIFIER/POWER SUPPLY FOIL PATTERN
FIGURE 10

OPERATING VOLTAGES

INPUT: 120 Vac, 60 Hz.
 AC TO BRIDGE Z201: 17 Vac, 60 Hz.
 BRIDGE DC OUTPUT: Vcc = 23 Vdc (Measure at J/P2-2)
 Regulated = 11.5 Vdc (Measure at J/P1-2)
 R103 VOLUME CONTROL: Minimum
 S102 SELECTOR SWITCH: AM (No Signal, Tune Off Station.)

DEVICE	PIN NUMBER															
	1	2	3	4	5	6	7	8	9	10	11	12	13	14	15	16
Z302	0.9	1.5	10.9	0.7	0	8	1.5	1.5	0.8	5.5	0.64		1	1	0	11

S1-2 SELECTOR SWITCH: FM (No Signal, Tune Off Station.)
 Regulated = 11.5 Vdc (Measure at J/P1-3)

DEVICE	PIN NUMBER															
	1	2	3	4	5	6	7	8	9	10	11	12	13	14	15	16
Z301	2.1	2.1	2.1	0	2.4*	5.4		5.9	6	6	10	5.3*		0		

(*) Must be measured by Oscilloscope or by meter with Hi-Z input.

DEVICE	ELEMENT				
	FUNCTION	SOURCE	GATE 1	GATE 2	DRAIN
Q301	R.F. Amplifier	1.7	1.85	3.6	8.6
		EMITTER	BASE		COLLECTOR
Q302	F.M. Mixer	0.25	0.9		10
Q303	F.M. Oscillator	4.5	5.2		4.2
Q201	I.C. Preamp	1.8	2.3		4.2
Q202	Key Click Suprsn	0	0*		0
Q203	1st Audio Amp.	1.5	2.0		10.5
Q204	Audio Amp.	10	10.5		19.5
Q205	Audio Amp.	20	19.5		10.6
Q206	Audio Driver	21.6	20		10.6
Q207	NPN Audio Output	9.8	10.4		22.5
Q208	PNP Audio Output	9.8	9.3		0
Q209	Voltage Regulator	11.6	12.0		23.0
Q210	Muting	0	0**		0
Q401/OFF	Door Relay	0	.049		20.1
Q401/ON		0	0.9		0.19
Q402/OFF	Key Click Suprsn.	0	0		0
Q402/ON		9.5	10		.25

(*) Goes to 0.3 on meter (0.8 on scope) when "Key Click" suppression voltage is ON.

(**) Goes to 0.7 when "Muting" is ON.

(***) Measured with meter. Actual voltage measured on scope equal 0.8 volts maximum; discharging to zero in 150-200 milliseconds when depressing or releasing any TALK or LISTEN switch

CONTROL MODULE INTERCOM OPERATION

INTERCOM OPERATING	CONTROL VOLTAGE	Z401A VOLTAGE	Z401B VOLTAGE	Z401C VOLTAGE	Z401D VOLTAGE	Q401/K401	Q410
MODE	POINT X	TERM. 9	TERM. 4	TERM. 5	TERM. 10	DOOR RELAY	AUDIO SWITCH
OFF	17.5	OFF	OFF	OFF	OFF	OFF	OFF
DOOR LISTEN	9.9	13.5	OFF	OFF	OFF	OFF	ON
DOOR TALK	5	OFF	11.3	OFF	11.3	ON	OFF
I/P TALK	2	OFF	OFF	13.5	13	OFF	OFF
I/P LISTEN	OFF	OFF	OFF	OFF	OFF	OFF	OFF
(MASTER ONLY)	MUTING VOLTAGE AT J2-5=1.4V; at Q210 Base=0.7V						

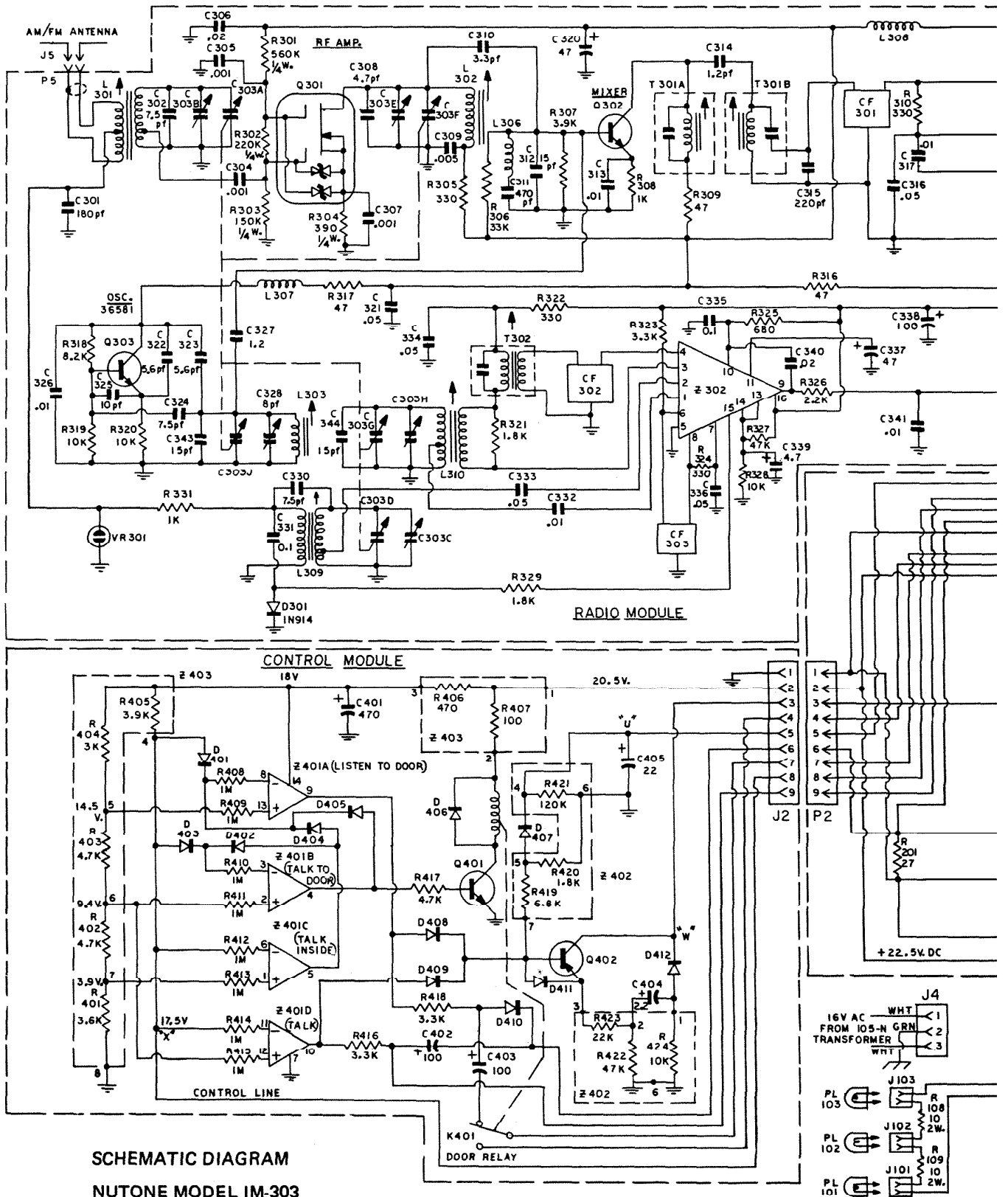

SCHEMATIC DIAGRAM
NUTONE MODEL IM-303
3-WIRE RADIO/INTERCOM MASTER UNIT

FIGURE 11

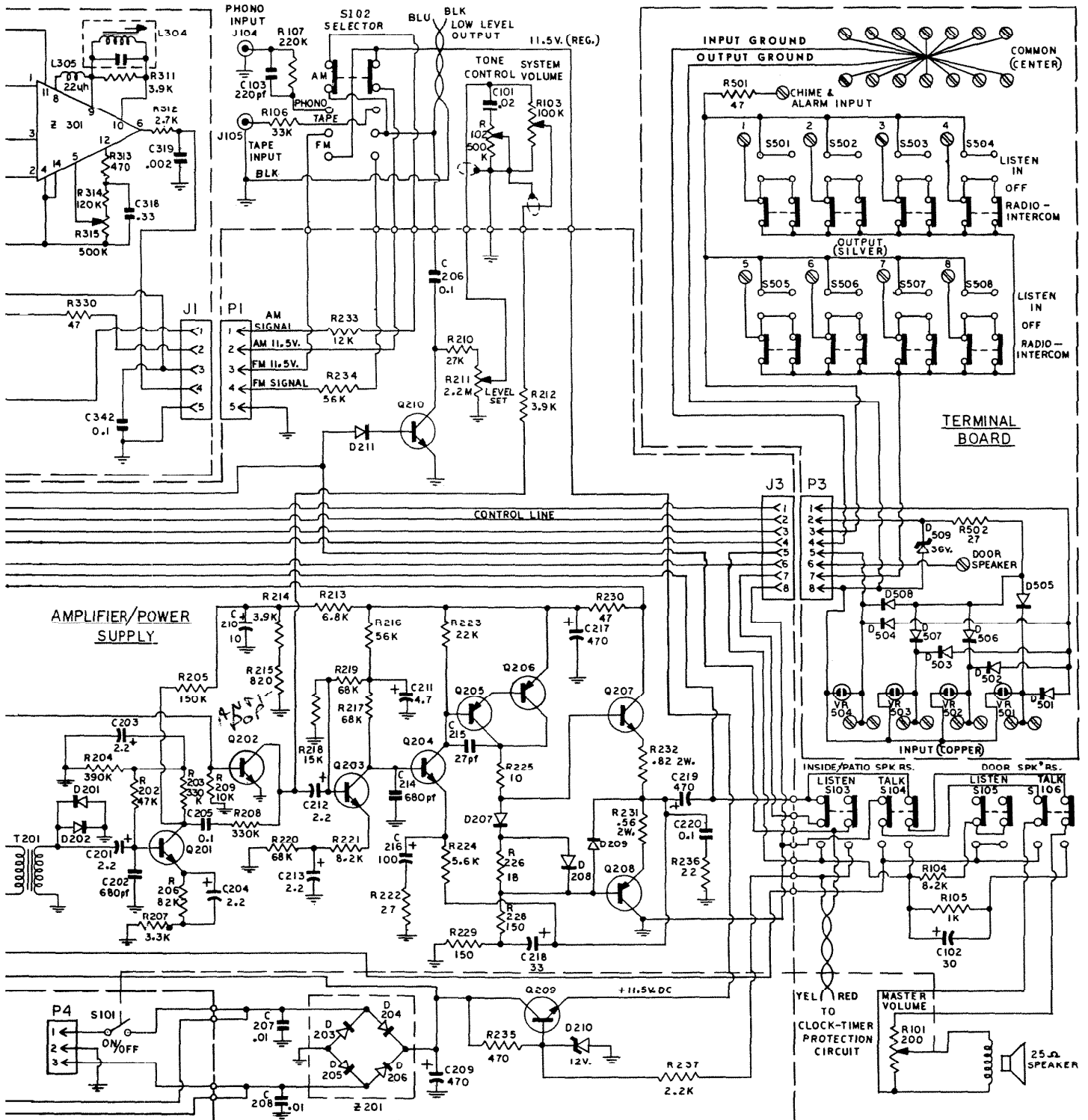

NOTE:

1. ALL RESISTORS: VALUES IN OHMS: 10% TOLERANCE: 1/2 WATT, UNLESS OTHERWISE SPECIFIED.
2. ALL CAPACITOR VALUE IN MFD., UNLESS OTHERWISE SPECIFIED.

COMPONENT IDENTIFICATION:

- | | |
|------------|-------------------------------|
| 100 SERIES | CHASSIS MOUNTED COMPONENTS |
| 200 SERIES | AMPLIFIER/POWER SUPPLY MODULE |
| 300 SERIES | RADIO MODULE |
| 400 SERIES | CONTROL MODULE |
| 500 SERIES | TERMINAL BOARD |

FIGURE 11

INTERCOM OPERATING MODE	CONTROL VOLTAGE POINT X	Z401A VOLTAGE TERM. 9	Z401B VOLTAGE TERM. 4	Z401C VOLTAGE TERM. 5	Z401D VOLTAGE TERM. 10	Q401/K401 DOOR RELAY	D410 AUDIO SWITCH
OFF	17.5	OFF	OFF	OFF	OFF	OFF	OFF
DOOR LISTEN	9.9	13.5	OFF	OFF	OFF	OFF	ON
DOOR TALK	5	OFF	11.3	OFF	11.3	ON	OFF
I/P TALK	2	OFF	OFF	13.5	13	OFF	OFF
I/P LISTEN (MASTER ONLY)	OFF	OFF	OFF	OFF	OFF	OFF	OFF

MUTING VOLTAGE AT J2-5 = 1.4V; at Q210 Base = 0.7V

NOTE
Diodes marked "c" Control
Diodes marked "as" Audio Switching

ELEMENT	Q401		Q402	
	OFF	ON	OFF	ON
E	0	0	0	9.3
B	0.05	0.9	0	10
C	20.1	0.19	0	0.3*

(*) Voltage measured when switch is depressed or released. On scope voltage will be approx. .8V decreasing to 0, in 150-200 milliseconds.

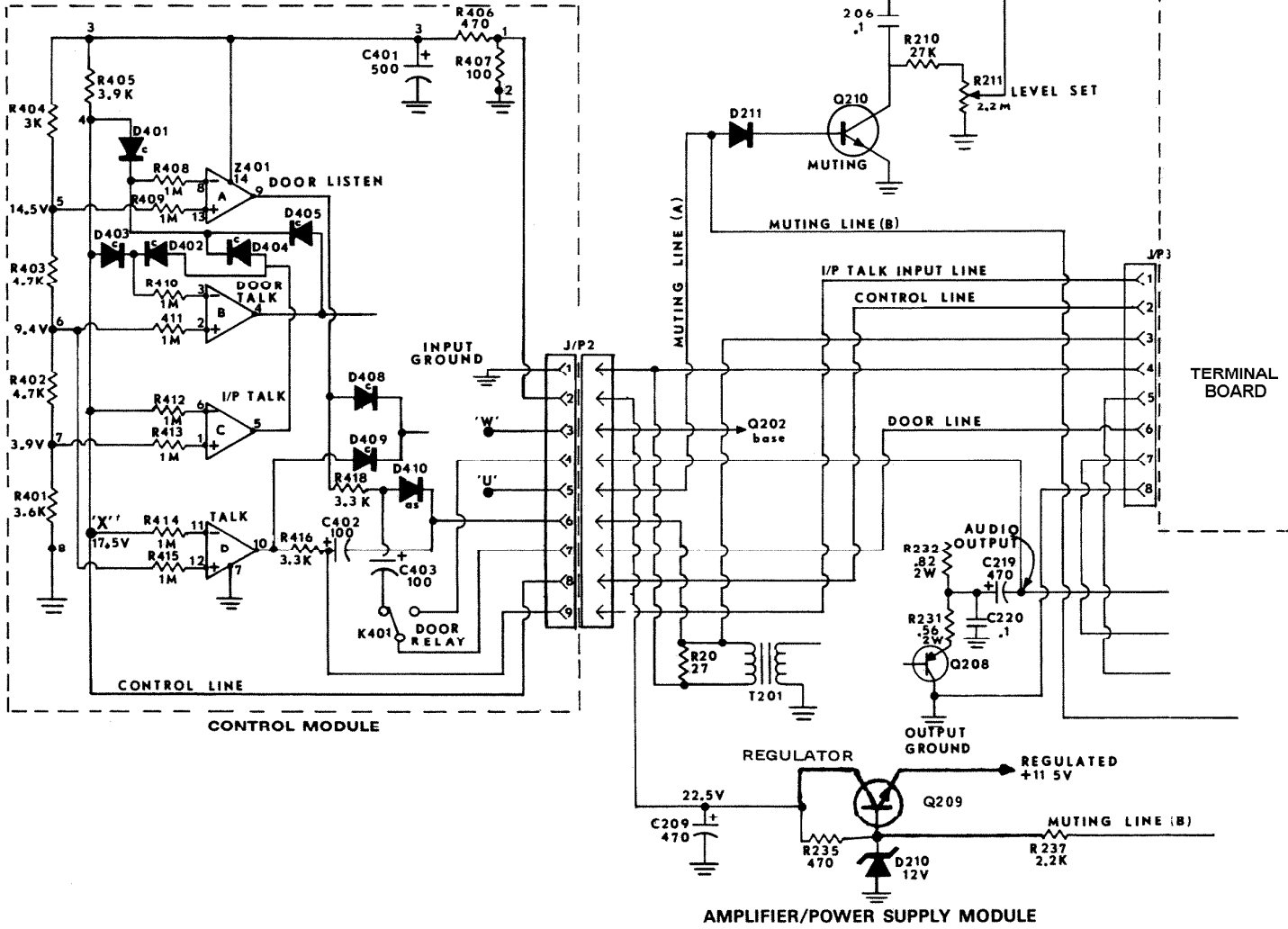

IM-303 SYSTEM INTERCOM

FIGURE 12

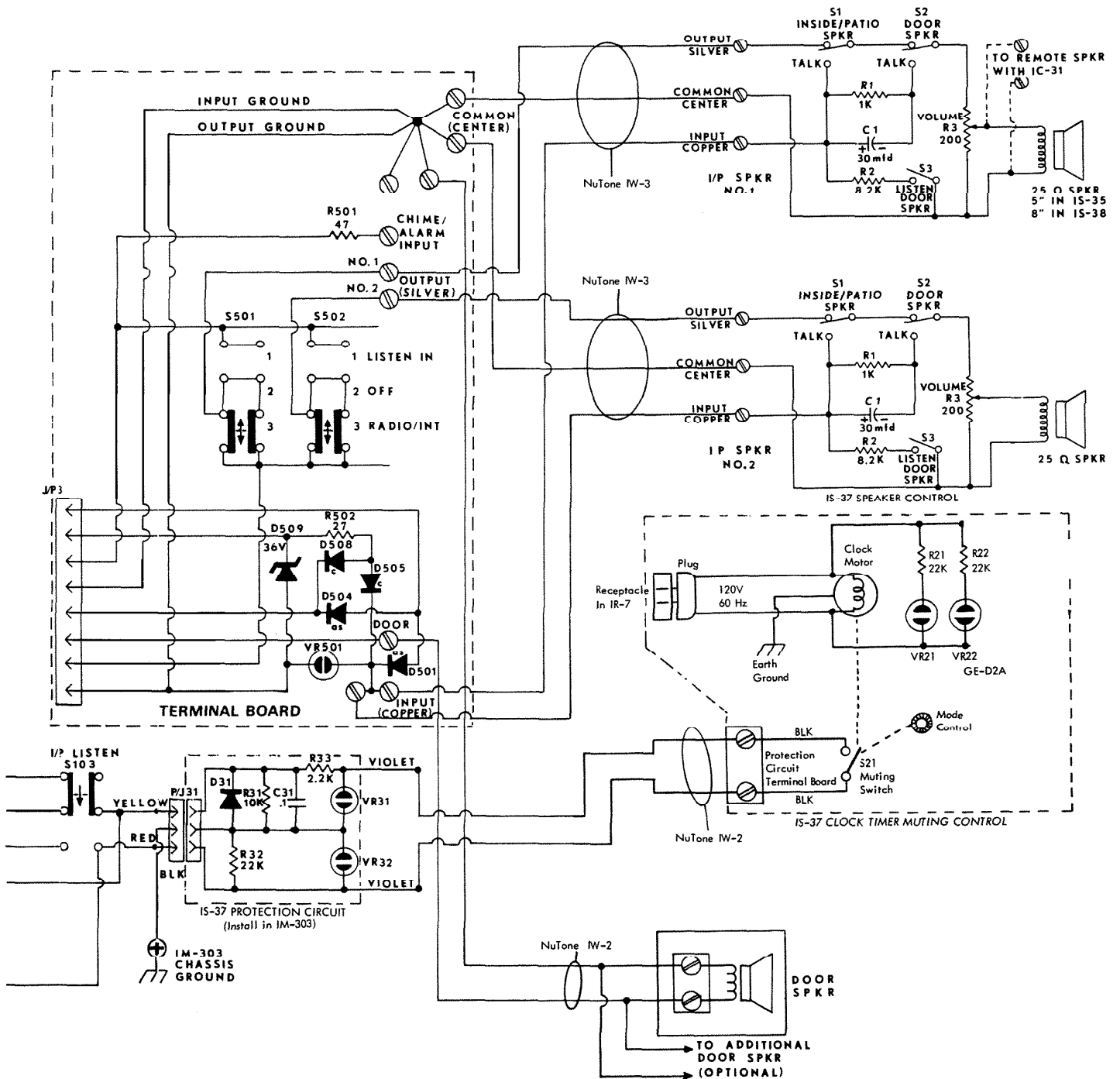
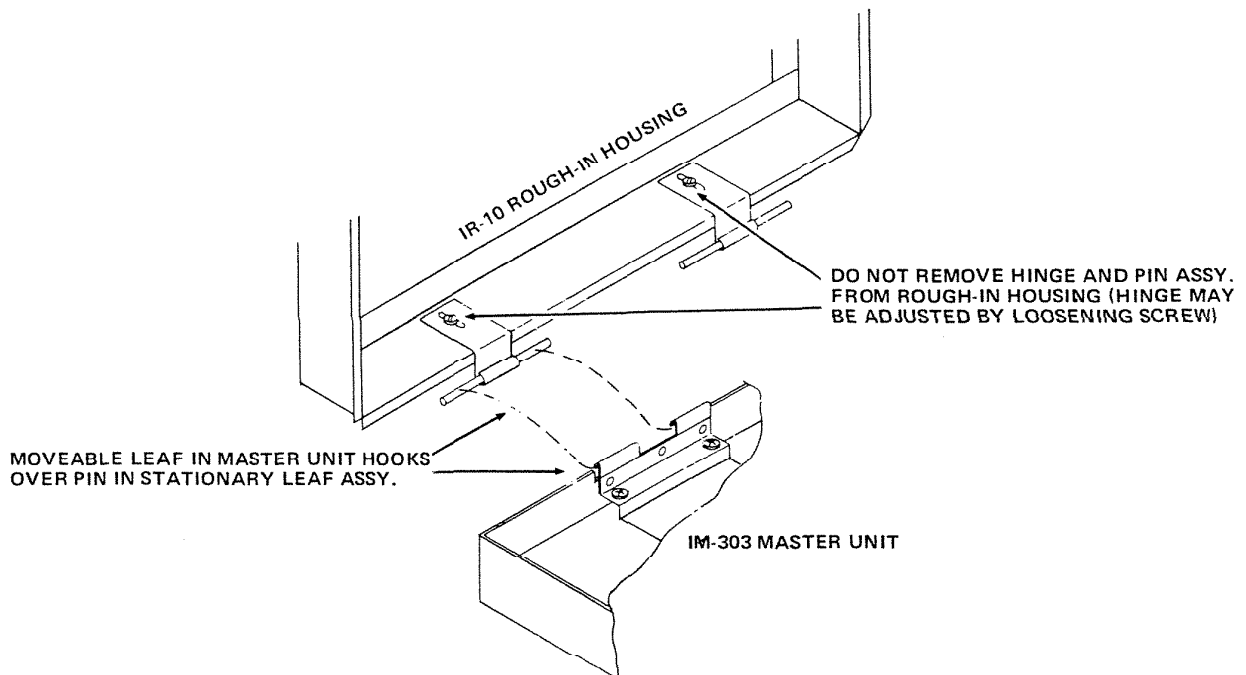

FIGURE 12



DETAIL OF LATER PRODUCTION HINGES

FIGURE 13

(From Page 16)

MENT PROGRAM AND INTERCOM SIGNALS WILL BE MUTED. THERE WILL BE NO POWER SUPPLY GROUND CONNECTION FOR THE CONTROL MODULE.

(4.6) TO OPERATE SET WHEN TERMINAL BOARD IS DISCONNECTED FROM THE CHASSIS, SHORT TERMINAL #4 TO TERMINAL #8 IN J3. THIS WILL PROVIDE A POWER SUPPLY GROUND FOR THE CONTROL MODULE.

(5) ORIGINAL PRODUCTION UNITS: (Figure 8)

(5.1) Remove screw holding the fixed leaf of

each hinge to the rough-in housing.

(5.2) Unfasten support strap at top of rough-in Housing and remove Master Unit.

(6) LATER PRODUCTION UNITS: (Figure 13)

(6.1) Support the Master Unit and unfasten support strap at top of rough-in housing.

(6.2) Lift Master Unit (with moveable leaf section of each hinge) up and away from the fixed leaf of each hinge.

IN THE FIELD TERMINAL BOARD REPLACEMENT

(1) Complete steps (3) and (3.1) under GENERAL above. (Figure 8)

(2) Disconnect the Terminal Board from Amplifier/Power Supply Module, i.e. P3 from J3.

(3) Disconnect interconnecting wires as shown in paragraphs (4.2) and (4.3) above.

(4) Remove the four Phillips head mounting screws (one in each corner) and lift Terminal Board out of unit.

(5) Install new Terminal Board, making certain that the Station Selector Switches S501-S508 are aligned with their mounting holes in the front of chassis — behind the door.

(6) Secure the Terminal Board in place with the four screws that were removed in step (4) above.

(7) Reconnect the I/P Speaker cables: The Silver (Output) wire of each cable must be connected to its proper Silver (Output) terminal. When required — for systems with more than eight I/P Speakers — two or more Silver wires may be connected to a Silver terminal. (Figure 2)

(7.1) Copper (Input) wires should be divided among the Copper terminals so as to equalize the load.

(7.2) THE CENTER (COMMON) WIRE OF EACH THREE-WIRE CABLE MUST BE CONNECTED TO AN INDIVIDUAL COMMON TERMINAL.

(8) Reconnect the Door Speaker wires and the chime/alarm wires to their proper terminals.

(9) Connect P3 to J3, i.e. to Amplifier/Power Supply module.

IN THE FIELD CONTROL MODULE REPLACEMENT

- (1) Some units (later production) have the mounting standoffs at front of module slightly twisted. These standoff tabs should be straightened (small pair of pliers may be used) before removing board.
- (2) Grasp Control Module gently but firmly and lift straight up — disconnecting J2 from P2.
- (3) Insert new module by fitting J2 to P2 and front mounting holes on chassis standoffs and press module gently but firmly in place. Do not press module down until it touches the chassis, but just far enough to make good contact between J2 and P2.
- (3.1) Later production units have a flexible plastic standoff around the two end pins (each side) of P2 to prevent pressing the module down too far.
- (4) When the Control Module is removed from the Master Unit, all of the I/P Speakers in RADIO/INTERCOM mode and the Master Unit speaker will continue to receive the entertainment program.
- (5) If the Master Unit I/P LISTEN SWITCH S103 is activated (pressed-in), the 12Vdc from base of

Q209/cathode of D210 will be connected through R237; contacts of S103; and D211 to the base of muting transistor Q210. This will result in silencing of the entertainment program.

- (5.1) If the system includes an IS-37 Speaker/Clock Timer and it is in the OFF; AUTO; or ALARM mode, the entertainment program will be muted.
- (6) With the Control Module removed from the chassis, I/P Speakers that are in LISTEN IN mode will be heard by the Master Unit Speaker and other I/P Speakers that are in RADIO/INTERCOM mode, and chime and/or alarm signals will be heard by the Master Unit Speaker and by I/P Speakers that are in RADIO/INTERCOM mode.
- (7) With the Control Module removed, all other intercom functions will be eliminated (excepting those noted in paragraphs (5) through (6) above).
- (8) If the Terminal Board is removed and the Control Module is removed, the entertainment program will be heard at the Master Unit Speaker, but there will be no Intercom Switching.

IN THE FIELD TUNER MODULE REPLACEMENT

- (1) Tune radio dial to lowest frequency — completely closing tuning capacitor C303.
- (2) To eliminate the necessity of restringing the dial cord when new Tuner Module is installed: Using masking tape, secure the dial cord in-place around the pulley and secure the dial cord spring and connecting points on front of pulley.
- (3) Remove the Phillips head machine screw; the retaining cap and lock washer securing the pulley, and then gently slide the pulley off the tuning capacitor shaft. Tape the pulley with dial cord in-place to the chassis.
- (4) Remove the screw holding the tuner grounding strap at the front left corner of the module.
- (5) Remove the retaining screw and standoff at the right rear of the module.
- (6) If the standoff mounting tabs in front of board are twisted, straighten with a pair of pliers before lifting module.

- (7) Gently but firmly lift the Tuner Module straight up — disconnecting J1 from P1.
- (8) Insert the new module by fitting J1 to P1 and the front mounting holes on the chassis standoffs and press gently but firmly in place. Do not press module down so that it touches the Amplifier/Power Supply or the chassis.
- (8.1) Insert plastic standoff between right rear corner of module and chassis and secure in place with screw that was removed in step (5) above.
- (9) Secure the module grounding strap with the screw that was removed in step (4) above.
- (10) Make certain that ganged tuning capacitor C303 is completely closed and gently install pulley (with dial cord intact), securing in place with cap; lockwasher; and screw that were removed in step (3) above.
- (11) Gently remove masking tape from pulley and check tuning dial tracking when TUNING KNOB is rotated.

REMOVING TUNER/AMPLIFIER ASSEMBLY FROM MASTER UNIT HOUSING

- (1) This complete assembly must be removed from the housing when installing new pilot lights and when replacing or repairing the Amplifier/Power Supply Module.
- (1.1) Because of the interconnecting wires and cables that are soldered to the Amplifier/Power Supply PC Board, it will generally be easier and quicker to replace or repair defective components on this board, than it is to replace the complete module.

- (2) Remove the TUNING KNOB and ON-OFF/MASTER SPEAKER VOLUME CONTROL Knob. Pull gently but firmly forward.
- (3) Disconnect Terminal Board P3 from Amplifier/Power Supply Module's J3.
- (4) If component to be repaired is on the Amplifier/Power Supply Module and is under the Tuner Module (such as Voltage Regulator Q209) and/or under the Control Module: These modules may be removed by following instructions above.

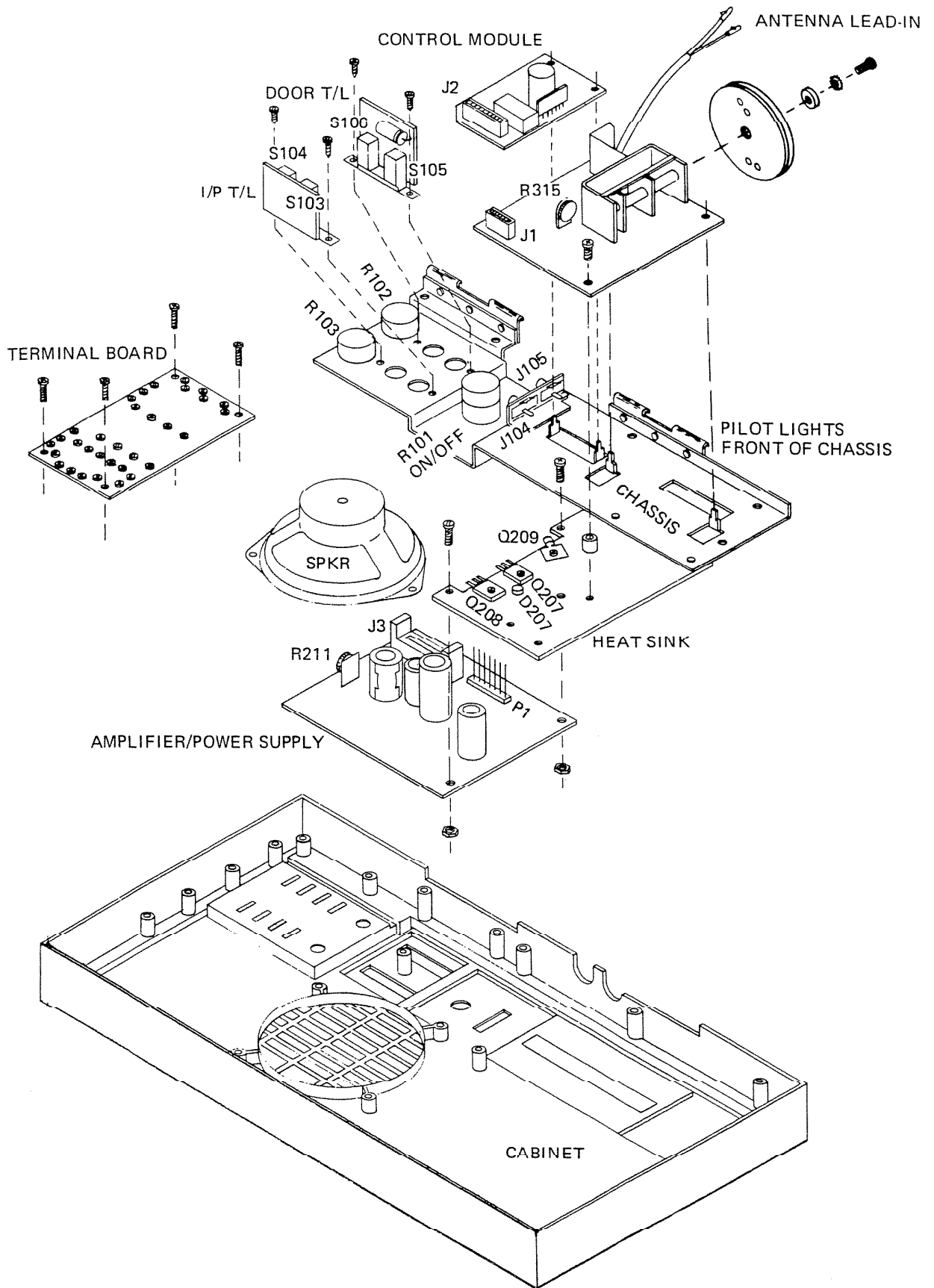

FIGURE 14: TUNER/AMPLIFIER CHASSIS ASSEMBLY EXPLODED VIEW

(5) Remove Terminal Board by extracting the four Phillips head mounting screws and lifting board out of Master Unit.

(6) Remove the eight, No. 8 Truss-Phillips-head screws that hold the chassis in the master unit.

REPLACING PILOT LIGHTS

(1) Remove chassis from Master Unit as described in paragraphs (1) through (3) and (5) through (7) above.

(2) Remove black guard from PROGRAM SELECTOR SWITCH S102.

(3) Remove two hex-head screws holding dial lens to chassis.

(4) Gently slide dial pointer from lens and lift lens and mounting bracket away from chassis.

(5) Replace defective lamp. Use G.E. #259 or equivalent (NuTone Part No. 39330-000). Normal

Note that one of these screws secures the P4 wiring assembly cable clamp.

(7) By gently folding the chassis over and without removing interconnecting wires and cables, the components on the Amplifier/Power Supply and Heat Sink may be removed or repaired.

lamp has a dc resistance of 20 ohms when cold. Burnt out lamps read "Open."

(6) Lamps are connected in series, if one lamp is burnt out, all lamps will be OFF. (Because of the time involved, it may be desirable to replace all three lamps when the unit is disassembled for pilot lamp replacement.)

(7) Slide lamps into wedge bases, making certain that wire contact on each side of bulb engages its base contact.

(8) Reassemble unit by reversing steps (1) through (4) above.

REPLACEMENT OF I/P AND DOOR TALK LISTEN SWITCHES

(1) Remove the rectangular switch knobs from the switches on the PC Board that, contains the defective switch.

(2) Using solder-sucker iron, unsolder contacts of defective switch on its PC Board.

(3) Remove the two screws holding the defective switch PC Board to chassis. Lift board away

from chassis far enough to remove the defective switch from board.

(4) Insert the new switch in PC Board and solder in place.

(5) Insert PC Board in chassis and secure in place with the two screws that were removed in step (3) above.

BENCH CHECKING THE MASTER UNIT

(1) Connect power plug P4 to 16Vac (NuTone 105-N transformer).

(2) Connect coax antenna cable from Tuner Module to test antenna.

(3) For complete checkout of Master Unit, the Terminal Board must be connected to the Amplifier/Power Supply Board, i.e. P3 to J3. If unit was removed from its installation without the Terminal Board, use a spare.

(3.1) If Terminal Board is not available, intercom operation can not be checked. To prevent muting of the entertainment program, short terminal #4

to terminal #8 in J3. If the terminals are not shorted, the Control Module may be removed to prevent muting.

(4) If available, connect an IS-38 or IS-35 Inside/Patio Speaker to the Terminal Board. Use IW-3 flat-3-wire cable and connect to proper terminals.

(5) Connect a speaker to DOOR terminal and common. (Use 16 ohm speaker if available.)

(6) Turn S101 ON and complete OPERATIONAL CHECKOUT procedure, pages 4 through 7.

SYSTEM TROUBLESHOOTING

(1) ENTIRE SYSTEM DEAD

CHECK: Connections at P4/J4.
16Vac from secondary of 105-N transformer.
Wiring between transformer and Master Unit.
120Vac supply to 105-N transformer.

(2) PILOT LIGHTS OFF — ALL OTHER FUNCTIONS NORMAL

CHECK: 16Vac at switch S101(B).
Wiring at terminals v and w on Amplifier/power supply module and pilot light circuit.
Pilot lamps PL101, PL102, PL103, R108 and R109.
Lamps must be properly installed in bases.

(3) NO FM — OTHER FUNCTIONS NORMAL

CHECK: FM antenna must be installed and connected to Tuner Module. It must not be shorted at PC Board.

Program Selector Switch S102.
FM connections between Switch S102 and Amplifier/Power Supply Module.
Regulated +11.5Vdc at S102 and P1-3.
J1 to P1 connections.
Voltages on Z301 and Q303. (See Schematic Diagram and Voltage Chart, pages 20-22).
FM tuner alignment.

(4) NO AM — OTHER FUNCTIONS NORMAL

CHECK: Antenna connections at terminal strip and on tuner module.
Program Selector Switch S102 — AM connections between switch and Amplifier/Power Supply Module.
Regulated +11.5Vdc at S102 and P1-2.
J1 to P1 connections.
Voltages on Z302. (See schematic diagram and Voltage Chart, pages 20-22).

- (5) **NO SOUND FROM MASTER UNIT SPEAKER — ALL REMOTE SPEAKERS OPERATING NORMALLY.**
 CHECK: Setting of Master Speaker Volume Control R101, S103, S104 and S106.
 Speaker and connections.
- (6) **NO SOUND FROM I/P SPEAKER(S) — MASTER UNIT SPEAKER OPERATING NORMALLY**
 CHECK: Station Selector Switches S501—S508, must be in Radio/Intercom mode.
 Connection of I/P Speaker wiring.
 Controls and connections at individual I/P Speakers.
 Flat 3-wire cable between I/P Speaker(s) and Master Unit Terminal Board.
 Connection at terminal #7 of J3/P3.
 S103.
 Wiring between J3/P3 and Terminal Board.
- (7) **DISTORTION AT ALL SPEAKERS**
 CHECK: Setting of Master Unit Speaker Volume Control; Volume Control at every I/P Speaker and Setting of Volume All Speaker Control R103. (See paragraph 6 through 9, page 4).
 Amplifier for proper operation, voltages, etc.
- (8) **MASTER UNIT ON — NO SOUND FROM ANY SPEAKER**
 CHECK: Program Selector Switch S102.
 P3 from Terminal Board MUST be plugged into J3. +22.5Vdc at terminal #2 J2/P2.
 Regulated +11.5Vdc at terminal #2 or #3 of J1/P1.
 Operating voltages on transistors in Amplifier/Power Supply Module.
 Individual Volume Controls at Master Unit Speaker and at I/P Speakers.
 All Speaker Volume Control R103.
 Level Set Control R211 on Amplifier/Power Supply Module.
 If system includes IS-37 Speaker/Clock Timer, make certain that its Mode Switch is in ON position. (See page 6)
- (9) **RECORD PLAYER AND/OR TAPE PLAYER SILENT — ALL OTHER OPERATIONS NORMAL**
 CHECK: Program Selector Switch S102 — must be in correct position
 Shielded cable between record player and/or tape player and J104 and/or J105 — must be pushed all the way in at both ends.
 Cartridge in Record Player.
 Record or tape of known quality should be used when checking units.
- (10) **HUM FROM RECORD PLAYER — ALL OTHER OPERATIONS NORMAL**
 CHECK: Shielded cable between Record Player and Master Unit — outer shield must make good contact at both ends.
 Separate ground wire between Record Player Rough-in and ground connection in Master Unit Rough-in.
 Connections to cartridge in Record Player.
- (11) **NO MUTING DURING INTERCOM OPERATION**
 CHECK: Control Module connections J2/P2.
 Muting voltage at terminal #5 of J2/P2.
 J3/P3 connections.
 Control Line Point "X" voltage at terminal #8 of J2/P2.
 Muting Transistor Q210 base voltage.
 Operating voltages on Quad Amplifier Z401.
- (12) **BACKGROUND MUSIC SYSTEM, BACKGROUND MUSIC MUTED DURING INTERCOM OPERATION**
 CHECK: See Muting Circuit Modification in Addendum.
 See BACKGROUND MUSIC, page 7.
- (13) **MUTING ON — WHEN NO TALK OR LISTEN SWITCH IS BEING ACTIVATED**
 CHECK: Talk/Listen switches in Master Unit and in I/P Speaker Controls. Must not be stuck, should work freely. Ground connection at terminal #1 of J2/P2 and at terminals #4 and #8 of J3/P3.
- Control Line Point "X" — resistance to ground should be very high when no Talk/Listen switch is activated.
 Quad Amplifier Z401 operating voltages.
 For collector to emitter short in Q202 and Q210.
 Shorts between INPUT (COPPER) and COMMON (CENTER) wires of the individual speaker cables.
- (14) **SIGNALS FROM CHIME AND/OR ALARM AND FROM SPEAKERS IN "LISTEN IN" MODE ARE TOO LOW**
 CHECK: Setting of Level Set Control R237. Lower volume of entertainment program, and increase the over-all volume of the system with System Volume Control R103. (See INTERCOM OPERATION, paragraphs (7.3) and (7.4), page 6.)
- (15) **NO INTERCOM SIGNALS FROM ANY SPEAKER OR FROM CHIME AND/OR ALARM — ALL OTHER FUNCTIONS NORMAL**
 CHECK: J3 to P3 connections.
 Intercom Input Transformer T201, D201, D202 and Q201.
 Check for "Key Click voltage on base of Q202, and for emitter-collector short in Q202.
 Q402-check operating voltages and for shorts between elements.
- (16) **DOOR SPEAKERS CANNOT RECEIVE NOR TRANSMIT INTERCOM SIGNALS — ALL OTHER FUNCTIONS NORMAL**
 CHECK: Wiring between DOOR and COMMON terminals and the Door Speaker. Should not be open or shorted.
 Connections at terminal #6 of J3/P3.
 Door wiring between DOOR terminal on Terminal Board and terminal #6 in P3.
 For shorted C501.
 Terminals #4, #6 and #7 of J2/P2.
 Door Relay K401.
- (17) **DOOR SPEAKER(S) CAN HEAR I/P AND MASTER UNIT SPEAKERS BUT CANNOT SEND SIGNALS TO I/P AND MASTER UNIT SPEAKERS — ALL OTHER OPERATIONS NORMAL**
 CHECK: C403, D410, R418, Z401A.
 Control Line Point "X" voltage at terminal #8 of J2/P2.
- (18) **DOOR SPEAKER(S) CAN SEND SIGNALS TO, BUT CANNOT RECEIVE FROM I/P AND MASTER UNIT SPEAKERS — ALL OTHER OPERATIONS NORMAL**
 CHECK: Door Relay K401.
 Control Line Point "X" voltage at terminal #8 of J2/P2.
 Z401B, R417, Q401.
 Connections at terminal #4 of J2/P2.
- (19) **SIGNALS CANNOT BE HEARD FROM I/P SPEAKER IN "LISTEN IN" MODE — ALL OTHER OPERATIONS NORMAL**
 CHECK: Individual I/P Speaker's volume control — turn to maximum. Check Paragraphs (7) to (7.4) page 5/6.
- (20) **HIGH PITCH SQUEAL**
 CHECK: Check for shorts between the SILVER (OUTPUT) wire and the COPPER (INPUT) wire in the flat-3-wire cables between the Terminal Board and the individual I/P Speakers. THE CENTER (COMMON) WIRE FROM EACH I/P SPEAKER MUST BE CONNECTED TO AN INDIVIDUAL COMMON TERMINAL. Shorts on Terminal Board or between wires in P3 wiring harness.
- (21) **LOW FREQUENCY FEEDBACK BETWEEN SPEAKERS DURING INTERCOM OPERATION.**
 CHECK: Volume setting of the offending speakers.
 Speakers must not be installed back-to-back on a common wall. Reduce volume of different speakers to determine acoustic coupling between individual speakers.
- (22) **SYSTEM PICKS UP RADIO INTERFERENCE.**
 CHECK: Make modifications as directed in Addendum.
- (29) **FM SQUELCH CONTROL FUNCTIONS POORLY ON WEAK FM STATION.**
 CHECK: Squelch Control Operation and Adjustment in Addendum.

ADDENDUM TO IM-303

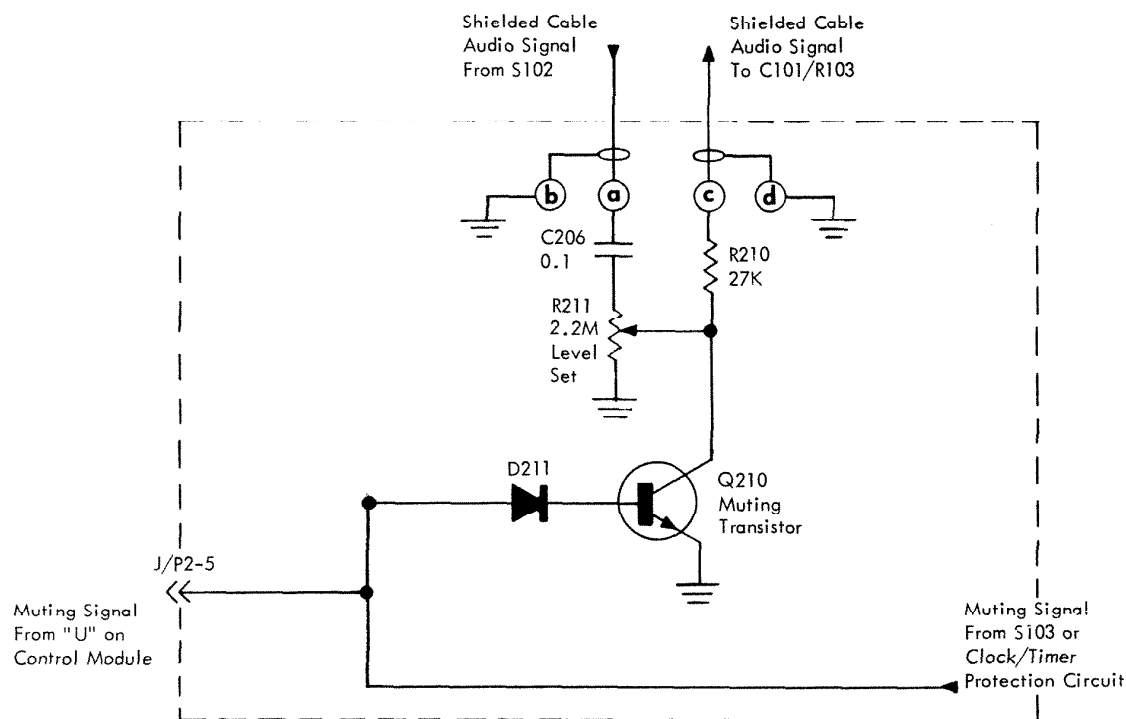

LATER PRODUCTION (OR MODIFIED) MUTING CIRCUIT
(Must be used in "Background Music" Systems)

FIGURE A1

MUTING CIRCUIT MODIFICATION

(1) Original production units, using Amplifier/Power Supply PC Boards marked 37599-1B (foil side) and 37599-2B (component side), were constructed with the muting circuit that is shown in the SYSTEM SCHEMATIC DIAGRAM.

(1.1) When used in "Background Music" systems, units constructed in this manner will mute the entertainment program when the Master Unit Speaker and I/P Speakers are operating in one of the intercom modes.

(2) To prevent muting of the entertainment program during intercom operation, the muting circuit should be as shown in Figure A1

(2.1) When constructed in this manner, muting in systems incorporating "Background Music" will operate as shown in BACKGROUND MUSIC section under OPERATIONAL CHECKOUT. (Page 7)

(3) To modify original production PC Boards, follow the instructions in Figure A2.

DC POWER SUPPLY MODIFICATIONS

(1) To aid in reducing diode rectifier switching noise, C207 and C208 — bypassing D203 and D205 respectively — were included in the original production units. Later production units will include C221 and C222 — bypassing D204 and D206 respectively. (See SCHEMATIC DIAGRAM and Figure A3)

(2) Original production units used a medium-power transistor (NuTone Part No. 36613-000) as the +11.5Vdc voltage regulator Q209. This transistor was secured to the main heat-sink by the small heat radiator (NuTone Part No. 36614-000).

(2.1) To prevent instantaneous destruction (open or short) of the voltage regulator Q209, later production units will use a heavier-duty device, i.e. Motorola MJE520 (NuTone Part No. 36614-000).

(3) To further protect against short circuiting; the 27-ohm, 2-watt, wire-wound resistor R239 (NuTone Part No. 33028-270) has been added to limit the short circuit collector current of Q209.

(3.1) R239 IS A 2-WATT RESISTOR. Being wire-wound, its physical size is approximately that of a one-watt carbon composition resistor.

(4) SHORT CIRCUITING OF THE REGULATED +11.5VDC SUPPLY MAY DESTROY THE VOLTAGE REGULATOR Q209. DO NOT SHORT TO GROUND WHEN MEASURING VOLTAGE OR WHEN ALIGNING TUNER. BE ESPECIALLY CAREFUL AROUND THE +11.5VDC TERMINAL ON SELECTOR SWITCH S102.

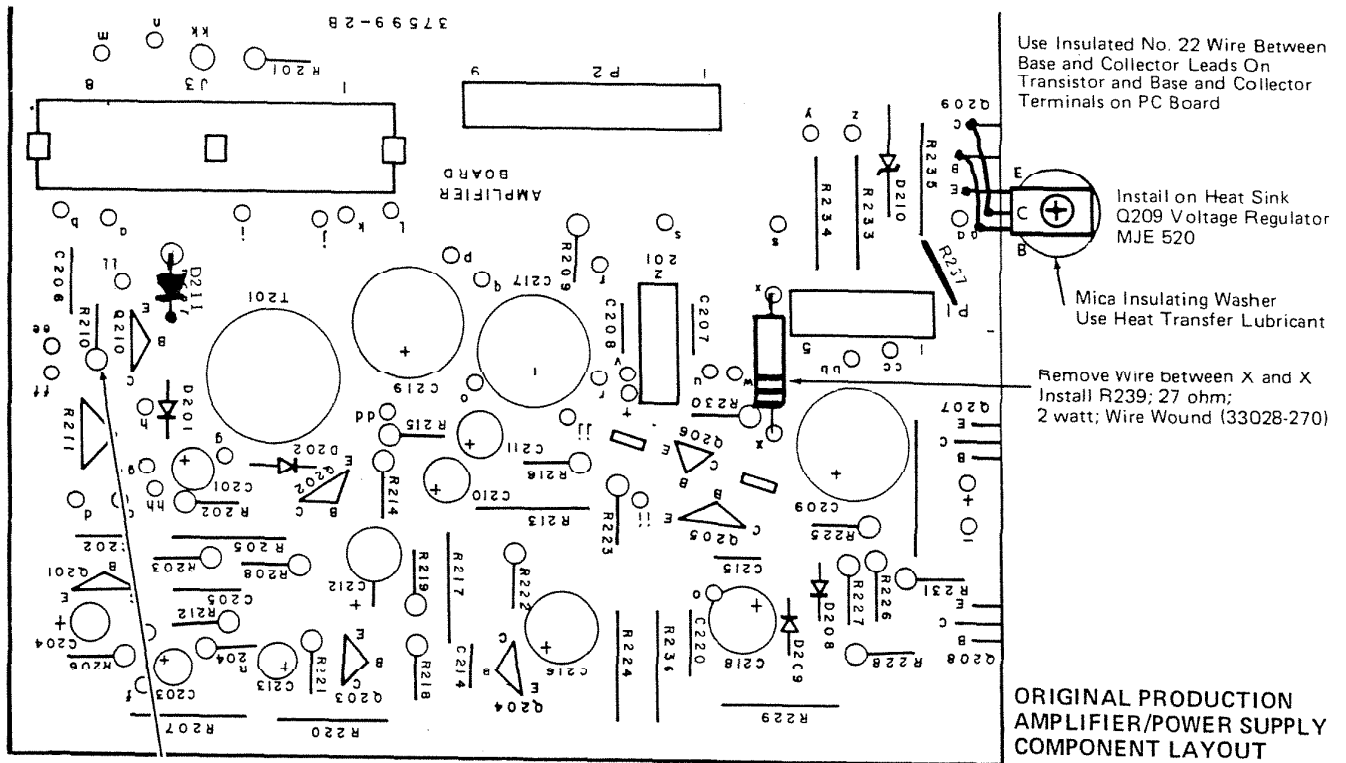

Remove H210 from PC Board.
Install Shorting Wire in vacated R210 position (Between C206 and hi-side of R211).

Break Foil Path between terminal 'c' and Wiper Contact of R211.
Install R210 between terminal 'c' and Wiper Contact of R211 (Foil Side).
Install jumper between junction of R210/Wiper Contact of R211 and Collector of Q210.

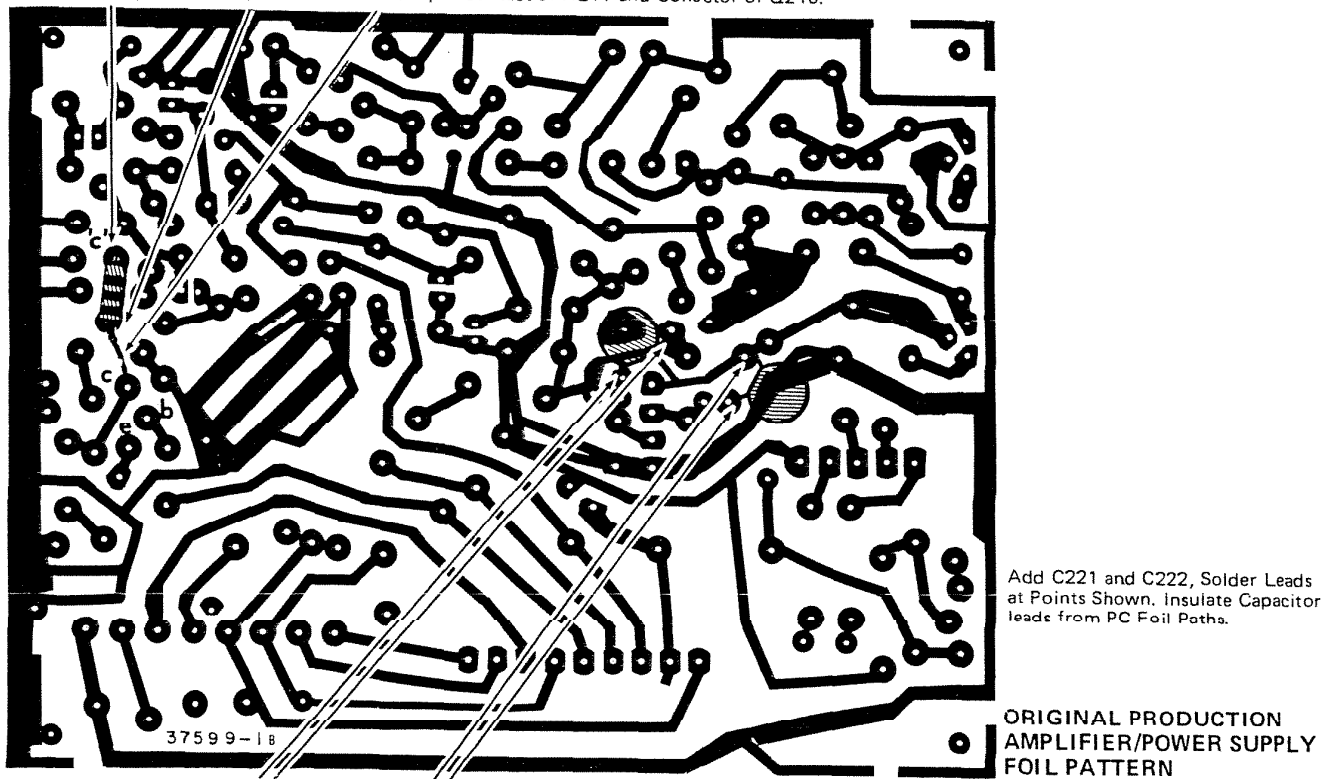

POWER SUPPLY & MUTING CIRCUIT MODIFICATION TO ORIGINAL PRODUCTION PC BOARDS
FIGURE A2

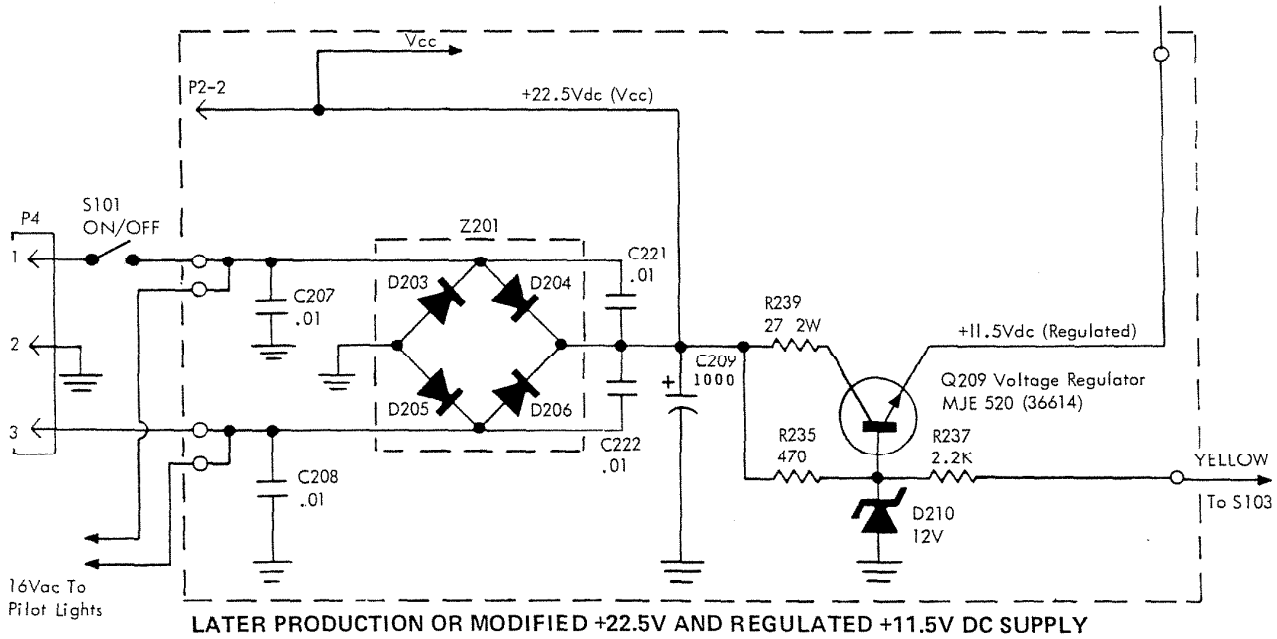

LATER PRODUCTION OR MODIFIED +22.5V AND REGULATED +11.5V DC SUPPLY

FIGURE A3

(5) Original production units used a 470 mf., 35 WVDC electrolytic capacitor for C209.

(5.1) Later production units will use a 1,000 mf., 35 WVDC capacitor (NuTone Part No. 35091-107) for C209.

(6) The DC power supply on original production PC Boards may be modified so as to agree with Figure A3 by following the instructions with Figure A2. (Note: Some of the earlier production boards will include some of these power supply modifications.)

NEW PC BOARDS

(1) New PC Boards for later production units will be as shown in Figure A4. These boards will be marked 37599-1C (foil side) and 37599-2C (component side).

(2) These new boards will include all of the modifications noted above and are interchangeable with original production boards.

able with original production boards.

(3) Because of the time involved in removing the interconnecting wires and shielded audio cables, it may be simpler and quicker to modify the original boards as noted above, and as directed in Figure A2.

R. F. INTERFERENCE

(1) Such interference may originate with A.M. and/or F.M. broadcasting stations; and from radar transmitters, homing devices; diathermy equipment; etc.

(2) When such interference is picked up on the DOOR line:

A .1 mf., 100 WVDC disc ceramic capacitor may be connected between DOOR and COMMON terminals on the Terminal Board. (This capacitor — C501, NuTone Part No. 35100-127 — is included in later production units, see Schematic Diagram.)

Also, it may be necessary to connect a .1 mf., 100 WVDC capacitor across (between cathode and anode) Door Switching Diode D410 on the Control Module.

(3) When the interference enters set through the INPUT (COOPER) line: Add a .1 mf., 100 WVDC ceramic capacitor between each pair of INPUT (COPPER) terminals and a COMMON (CENTER) terminal on the Terminal Board.

(4) When interference enters set through the PHONO and/or TAPE INPUTS, a shorted RCA phono-plug may be inserted in J104 and/or J105.

(5) If the interference is entering the system across components on the Amplifier/Power Supply Module, the following capacitors should be added:

100 pf., 100 WVDC, ceramic disc capacitor should be added between base and emitter of Q201; (NuTone Part No. 35100-131)

100 pf. between base and emitter of Q202;

100 pf. between base and emitter of Q203;

100 pf. between base and emitter of Q204;

.1 mf. between emitter of Q204 and ground;

.1 mf. from contact of ON/OFF SWITCH S101 and Ground.

(6) In all cases, the capacitor leads should be as short as possible. The leads must not short the foil paths on the PC Boards.

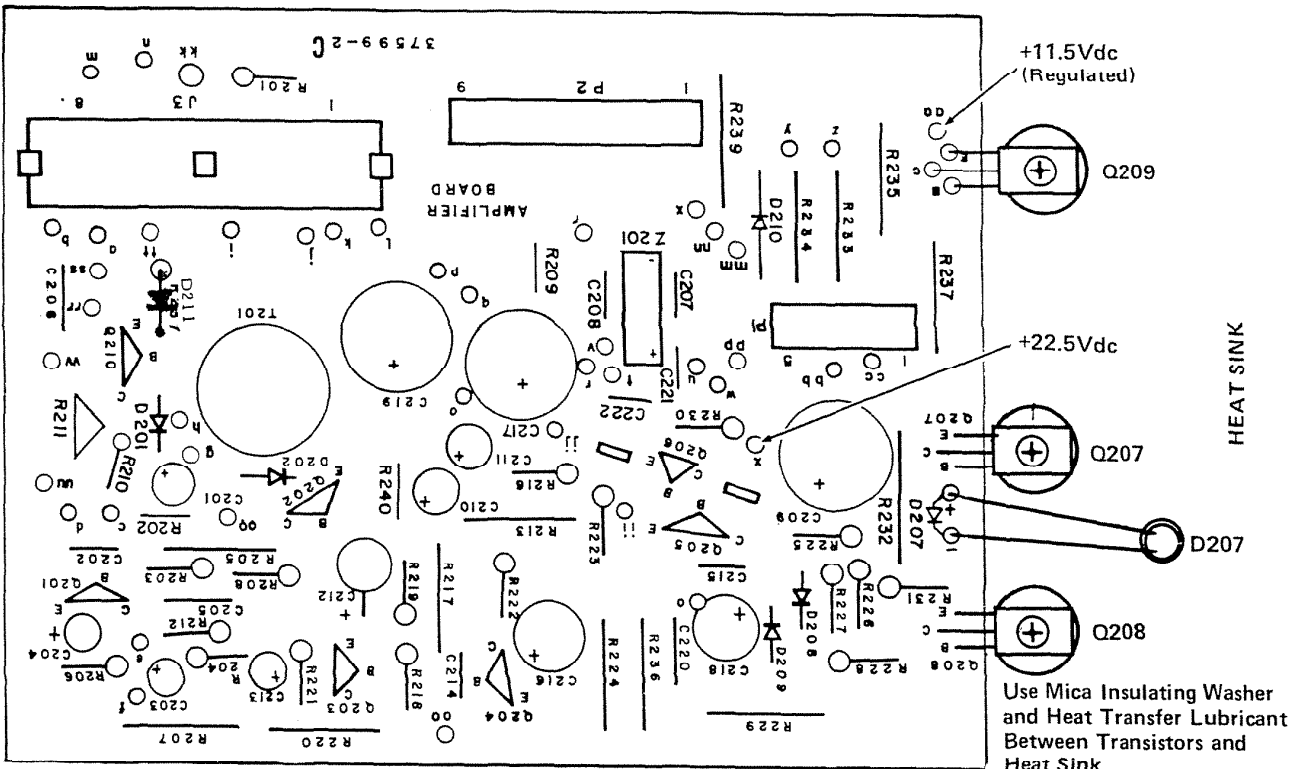

COMPONENT LAYOUT

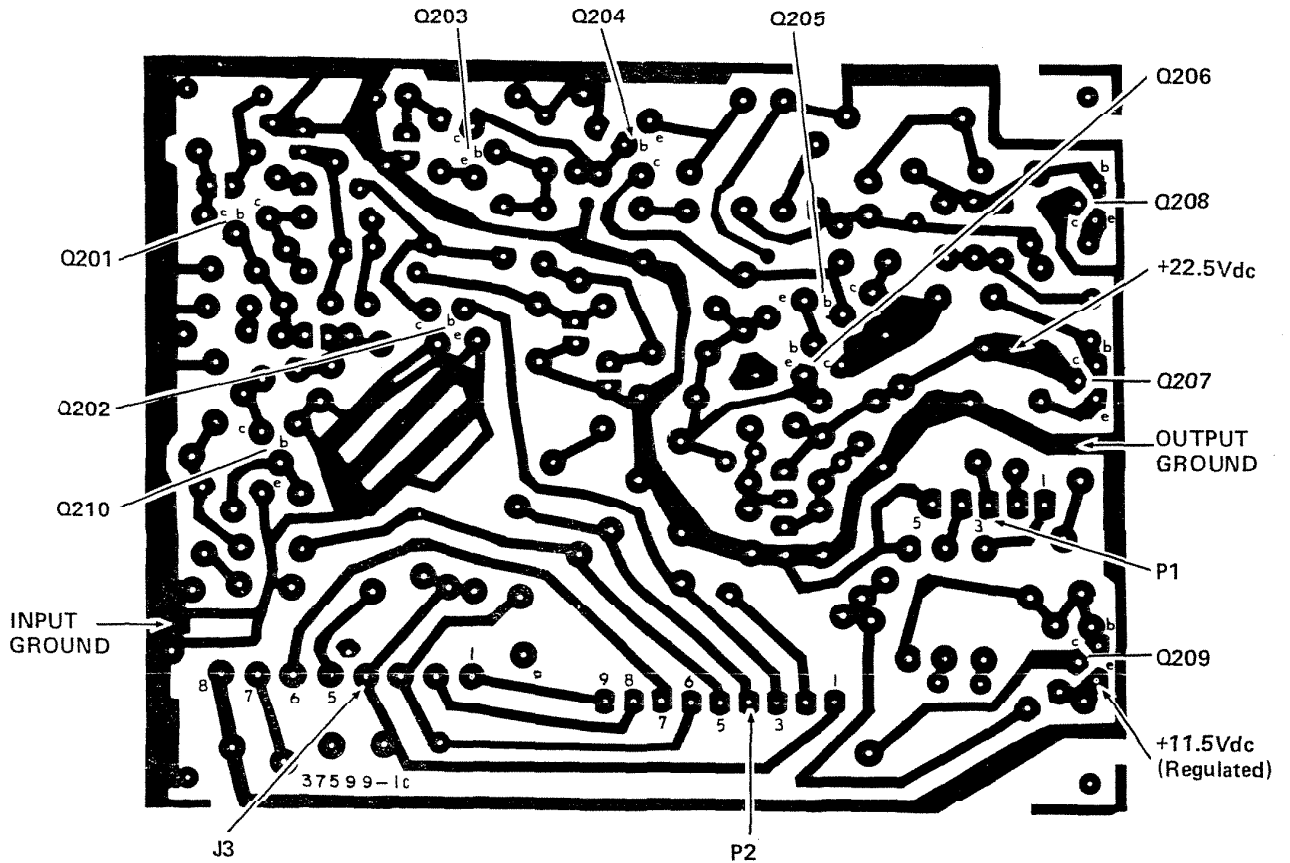

FOIL PATTERN

FIGURE A4: LATER PRODUCTION AMPLIFIER/POWER SUPPLY MODULE

(7) Because of the many variations in the pick up of such R.F. interference, no definitive procedure, that will work in every case, can be presented. In general, experiment and experience

will lead to isolation of the source of entry for the unwanted signals, and the procedures listed above can be followed.

SETTING OF F.M. SQUELCH CONTROL R315

(1) The Master Unit is supplied, from the factory, with Squelch Control R315 set at maximum position, i.e. with full squelch.

(2) When sufficient (normally excess of 5 microvolts) F.M. broadcast band R.F. signal is fed to the input of the F.M. tuner, it will operate with full limiting and the setting of R315 will not effect the quantity nor quality of the recovered audio signal, and the signal-to-noise ratio will be in the order of 45 db. As the input signal increases, the signal-to-noise ratio will rise to the order of 70db. (See Figure A5)

(3) When there is sufficient RF signal and the squelch can be operated at maximum, the side-band response that is characteristic of limiter-discriminator F.M. operation will be eliminated. (Figure A6) The set will be quiet when tuned between stations, and tuning is as easy and unambiguous as in an AM receiver-without resorting to AFC. This eliminates AFC pull from a strong station when attempting to tune to a weak station.

(4) When the RF input is below 5 microvolts, due to: distance from transmitter (fringe area); poor antenna; shielded RF area; etc., there will not be sufficient signal to drive the set to limiting, and it may be required that the squelch control be set to a lower point.

(4.1) This may improve listening satisfaction, but the receiver may be operating at a point where signal-to-noise ratio has deteriorated and the recovered audio is not acceptable.

(5) In the field adjustment of the Squelch Control R315 may be accomplished as follows:

(5.1) Set ALL SPEAKER VOLUME CONTROL R103 and MASTER UNIT SPEAKER VOLUME CONTROL R101 for normal operation.

(5.2) Set SQUELCH CONTROL R315 to minimum, i.e. no squelch.

(5.3) Tune receiver to weakest F.M. station that the home owner will normally listen to.

(5.4) If the weak station (paragraph (5.3) above) reception is acceptable, advance the SQUELCH CONTROL R315 until it interferes with reception of the station, then, back the control until reception is acceptable.

(6) IN NORMAL OPERATION, WITH THE FM TUNER PROPERLY ALIGNED, THE RECOMMENDED PROCEDURE IS TO IMPROVE THE

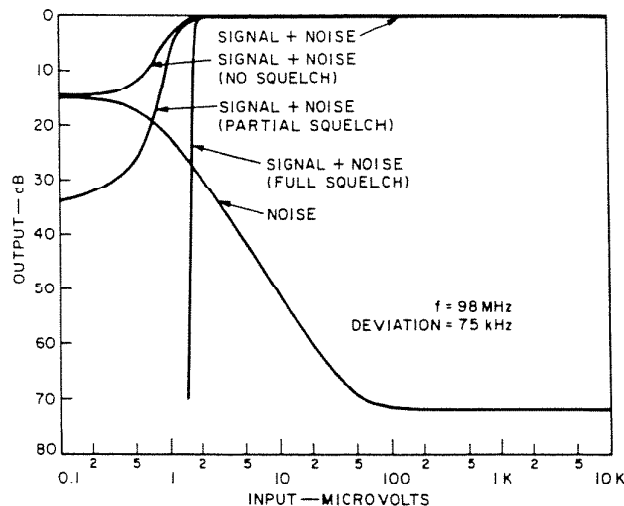

S + N AND N FOR NO SQUELCH; PARTIAL SQUELCH; AND FULL SQUELCH PLOTTED AGAINST RF INPUT

FIGURE A5

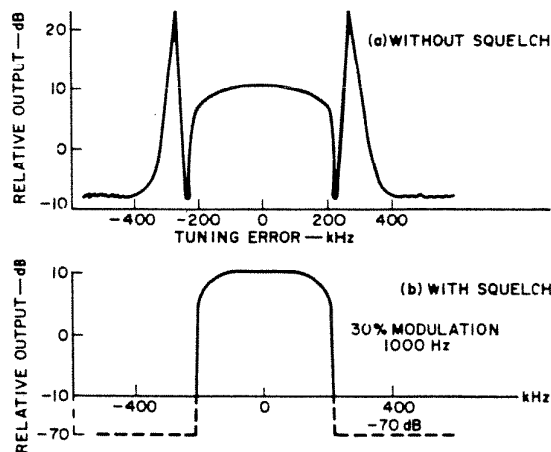

TYPICAL TUNING CHARACTERISTIC: (a) WITHOUT SQUELCH; AND (b) WITH SQUELCH, SHOWING THE SUPPRESSION OF SIDE RESPONSE CHARACTERISTIC OF LIMITER - DISCRIMINATOR RECEIVERS

FIGURE A6

R.F. SIGNAL INPUT. THIS MAY BE ACCOMPLISHED BY INSTALLING AN OUTSIDE ANTENNA, AND IF REQUIRED, A DIRECTIONAL ARRAY; RAISING THE ANTENNA; OR BY CHANGING THE POSITION OF THE INSIDE ANTENNA THAT IS SUPPLIED WITH THE MASTER UNIT ROUGH-IN.

REMEMBER, SUB-PAR OPERATION OF THE SQUELCH CIRCUIT IN A WELL ALIGNED MASTER UNIT IS DUE TO INSUFFICIENT INPUT SIGNAL.

REPLACEMENT PARTS LIST

IM-303 3-WIRE BUILT-IN RADIO/INTERCOM SYSTEM

All Resistors: Value in ohms, 1/2 Watt Carbon Composition unless otherwise noted.
 All Capacitors: Value in farads, 500 WVDC Ceramic unless otherwise noted.
 K (Kilo) = 1,000 M (Mega) = 1,000,000 m (micro) = 10⁻⁶ p (pico) = 10⁻¹²

Schematic Symbol	NuTone Part No.	Description
IM-303 MASTER UNIT		
(*) Used in IM-303-D Walnut Only		
(**) Used in IM-303-L Golden Elm Only		
	13045-900*	Complete Assembly
	13047-900**	Complete Assembly
	41525-000	Chassis Assembly Complete
AM/FM TUNER MODULE		
	41533-000	Complete Assembly
	37596-000	PC Board
	38637-003	FM RF Shield
	41524-000	Antenna Coax Lead-in Assy. (with Connectors)
CAPACITORS		
C301, C329	35100-161	180 pf.
C302, C324, C330	35101-135	7.5 pf.
C303A-J	35092-000	Variable, AM/FM Gang Tuning
	31893-000	Tuning Shaft
	31894-000	Bushing, Tuning Shaft
	41535-000	Dial Cord Assembly
	39327-000	Pulley, Tuning Capacitor Dial String
	39135-000	Cap, Pulley, Tuning Capacitor
	31872-000	Lock Washer, Pulley, Tuning Capacitor
	39262-000	Spring, Pulley, Dial Cord
	39335-000	Dial Pointer
C304, C305, C307	35100-120	.001 mf.
C306, C340	35100-140	.02 mf., 50 WVDC
C308	35101-129	4.7 pf.
C309	35100-138	5,000 pf.
C310	35101-134	3.3 pf.
C311, C315	35100-125	220 pf. (C311, Trap)
C312, C343, C344	35101-142	15 pf.
C313, C317, C326, C332, C341	35100-139	.01 mf., 50 WVDC
C314, C327	35101-126	1.2 pf.
C316, C321, C333, C334, C336	35100-141	.05 mf.
C318	35094-000	.33 mf.
C319	35100-156	2200 pf.
C320, C337	35091-109	47 mf. Electrolytic, 16 WVDC
C322, C323	35101-141	5.6 pf.
C325	35101-140	10 pf.
C328	35090-000	1-8 pf., Variable, Oscillator Hi-Frequency Trimmer, 100 WVDC/AC

Schematic Symbol	NuTone Part No.	Description
C331, C335, C342	35100-127	.1 mf., 100 WVDC
C300	35091-108	100.mf., Electrolytic, 25 WVDC
C339	35091-103	4.7 mf., Electrolytic, 25 WVDC
COILS AND TRANSFORMERS		
L301	30087-000	FM Ant. Primary
	30086-000	FM Ant. Trap
	30085-000	FM Ant. Secondary
L302	30089-000	FM RF
L303	30088-000	FM Oscillator
	30073-000	Coil Form, for L301, L302, L303
	31915-000	Slug, Tuning Core, for L301, L302, L303
	30092-000	10.7 MHz. Quadrature Detector Tuning
L305	30091-101	22 mH., RF Choke
L306	30062-000	10.7 MHz. Trap Coil
L307, L308	30090-000	10.7 MHz. Choke
L309	30578-000	AM Ant. Transformer
L310	30093-000	AM Oscillator
T301A	30590-000	10.7 MHz. FM IF Primary
T301B	30591-000	10.7 MHz. FM IF Secondary
T302	30589-000	455 KHz. AM IF
CONNECTOR		
J1	39339-101	5-Pin Receptacle
DIODES		
D301	36617-000	Silicon Switching, 50 ma. DC; 75 PIV 1N914 Texas Inst. 1N4148
FILTERS		
CF301	36088-000	10.7 MHz. FM IF. Ceramic Vernitron Piezoelectric Div. FM-4 (Preferred) Murata Corp. of America SFG-10.7MA
CF302, CF303	36087-000	455 KHz., AM IF, Ceramic Murata Corp. of America SFB-455D
LAMPS		
VR301	39438-000	Neon, 105-125Vdc/ac; 1/4 watt; 1.9 ma. G.E. "Glow Lamp" #C2A-ET (NE-2H3T) or Equivalent
RESISTORS		
R301	33081-564	560K, 1/4 Watt
R302	33081-224	220K, 1/4 Watt
R303	33081-154	150K, 1/4 Watt
R304	33081-391	390, 1/4 Watt
R305, R310, R322, R324	33101-331	330
R306	33101-333	33K
R307, R311	33101-392	3.9K

Schematic Symbol	NuTone Part No.	Description
R308, R331	33101-102	1K
R309, R316 R317	33101-470	47
R312	33101-272	2.7K
R313	33101-471	470
R314	33101-124	120K
R315	34043-000	500K, Potentiometer Trim, FM Squelch
R318	33101-822	8.2K
R319, R320, R328	33101-103	10K
R321, R329	33101-182	1.8K
R223	33101-332	3.3K
R325	33101-681	680
R326	33101-222	2.2K
R327	33101-473	47K
R330	33101-101	100
TRANSISTORS		
Q301	36624-000	Dual Gate FET, FM RF Amplifier, General Inst. Corp., MEM 615A, MEM 614
Q302	36578-000	NPN Epitaxial Planar Silicon, FM Mixer Texas Inst. SKA-4231 Motorola Inc., SPS-4448 National Semiconductor, SM-43-049
Q302	36501-000	NPN Planar Silicon, FM Oscillator Texas Inst. SKA-4230 National Semiconductor, SM-43-050
INTEGRATED CIRCUITS		
Z301	36623-000	FM IF, Detector RCA CA3089E S.G.S. ATES Co. TDA 1200
Z302	36622-000	AM Mixer, IF, Detector RCA CA3088E
AMPLIFIER/POWER SUPPLY MODULE		
	41529-000	Complete Assembly
	37599-000	PC Board
CAPACITORS		
C201, C203, C204, C213	35091-111	2.2 mf., 25 WVDC, Electrolytic
C202, C214	35100-164	680 pf.
C205, C206, C220	35100-127	.1 mf., 100 WVDC
C207, C208, C221, C222	35100-139	.01 mf., 50 WVDC (C221, C222 in Later Production Only)
C209, C217	35091-101	470 mf., 35 WVDC, Electrolytic (C209 Original Production)
C209	35091-107	1,000 mf., 35 WVDC, Electrolytic (Later Production)
C210	35091-102	10 mf., 10 WVDC, Electrolytic
C211	35091-103	4.7 mf., 25 WVDC, Electrolytic
C212	35068-106	2.2 mf., 50 WVDC, Electrolytic

Schematic Symbol	NuTone Part No.	Description
C215	35100-162	27 pf.
C216	35091-108	100 mf., 25 WVDC, Electrolytic
C218	35091-104	33 mf., 25 WVDC, Electrolytic
C219	35091-105	470 mf., 25 WVDC, Electrolytic
CONNECTORS		
J3	39333-101	4-Pin End Black Connector (Left Light Blue)
	39333-102	4-Pin End Black Connector (Right Dark Blue)
J4	41541-000	Jack and Wire Assembly
P1	39338-101	5-Pin Connector Post Assembly
P2	39338-104	9-Pin Connector Post Assembly
P4	41534-000	Plug and Wire Assembly
DIODES		
D201, D202, D208, D209, D211	36549-000	Silicon Rectifier, 1 Amp. DC; 100 PIV, 1N4002 (D211 used in Later Production Only)
D207	36589-000	Silicon, Temperature Tracking, 120 ma DC; 100 PIV, 1N3754
D210	36539-000	Silicon, Zener, 12 V, 1N4742A
Z201	36618-000	Silicon Bridge Rectifier Assembly, includes D203, D204, D205, and D206; DC Output 1.5A, PIV 100, General Inst. Corp. KPB02
RESISTORS		
R201, R222	33101-270	27
R202	33101-473	47K
R203, R208	33101-334	330K
R204	33101-394	390K
R205	33101-154	150K
R206	33101-823	82K
R207	33101-332	3.3K
R209	33101-103	10K
R210	33101-273	27K
R211	34023-000	2.2M Potentiometer Trim, LEVEL SET
R212, R214	33101-392	3.9K (R214 Early Production Only)
R213	33101-682	6.8K
R215	33101-821	820 (Early Production Only)
R216, R234	33101-563	56K
R217, R219	33103-683	68K Metal Film
R218	33103-153	15K Metal Film
R220	33101-683	68K
R221	33103-822	8.2K Metal Film
R223	33101-223	22K
R224	33101-562	5.6K
R225	33101-100	10
R226	33101-180	18
R227		Not Used
R228, R229	33101-151	150
R230	33101-470	47
R231	33046-000	0.56, 2-Watt

Schematic Symbol	NuTone Part No.	Description
R232	33048-000	0.82, 2-Watt
R233	33101-123	12K
R235	33101-471	470
R236	33101-220	22
R237	33101-222	2.2K
R239	33028-270	27, 2-Watt, Wire-Wound
R240	33101-472	4.7K (Later Production, Replaces R214 & R215)
TRANSFORMER		
T201	30593-000	Intercom Input
	32159-003	Mounting Bracket for T201
TRANSISTORS		
Q201, Q203, Q204	36580-000	NPN Planar Silicon: Low Noise, Texas Inst. SKA-4220; Motorola Inc. SPS-1216; Nat. SemiCon. SMO-7329; 2N5088
Q202, Q210	36613-000	NPN Silicon, Texas Inst. TIS-98, Motorola MPS A20
Q205	36577-000	PNP Epitaxial Planar Silicon Texas Inst. SKA-4223; 2N5086
Q206	36603-000	Power, PNP Silicon: Motorola MPS-U55
	38105-003	Mounting Bracket for Q206
	40975-000	Q206/Bracket Assembly
Q207	36614-000	Power, NPN Silicon, Single Diffused: Motorola MJE 520
Q208	36619-000	Power, PNP Silicon, Single Diffused: Motorola MJE 371
Q209	36610-000	Voltage Regulator, NPN Silicon, Texas Inst. TIS-98; Motorola MPS A20 (Early Production Units)
Q209	36614-000	Voltage Regulator, NPN Silicon, Single Diffused, Motorola MJE 520 (Later Production Units)
	39360-000	Mica Washer, Output Transistor Insulator (and Q209, Part No. 36614-000)
	38500-000	Heat Sink
	38574-000	Heat Sink (Use with Q209 Regulator, 36613-000 Only)
CHASSIS MOUNTED COMPONENTS		
	37605-000	PC Board, Door Talk/Listen
	37606-000	PC Board, I/P Talk/Listen
CAPACITORS		
C101	35100-165	.02 mf. \pm 20%
C102	35068-104	30 mf., 30 WVDC Electrolytic
C103	35101-143	220 pf.
CONNECTORS		
J101, J102, J103	31451-003	Base, Pilot Lamps
J104, J105	41528-000	Bracket and Jack Assembly, PHONO and TAPE inputs
	46388-000	Label, Phono-tape

Schematic Symbol	NuTone Part No.	Description
LAMPS		
PI 101, PI 102, PL103	39330-000	Pilot, G. E. #250 (or Equivalent)
RESISTORS		
R101	34062-000	200 ohm Potentiometer, Master Unit Speaker Volume Control (Ganged with S101 ON/OFF)
R102	34060-000	500K ohm, Potentiometer, TONE CONTROL
R103	34061-000	100K ohm Potentiometer System VOLUME CONTROL
R104	33101-822	8.2K
R105	33101-102	1K
R106	33101-333	33K
R107	33101-224	220K
R108, R109	33028-100	10, 2-Watt, Wire Wound
SWITCHES		
S101	34062-000	ON/OFF (Ganged with Master Unit VOLUME Control R101)
S102	34622-000	DP4T, Slide, PROGRAM SELECTOR
	39437-000	Guard, Black, for S102
S103, S104, S105, S106	34631-000	DPDT, Slide, Momentary TALK & LISTEN
	34628-000	Alternate
KNOBS		
	39355-000*	Master Speaker VOLUME
	39379-000**	Master Speaker VOLUME
	39346-000*	TUNING
	39380-000**	TUNING
	31878-000	Black Rectangular, Push-button, TALK/LISTEN
CONTROL MODULE		
	41531-000	Complete Assembly
	37597-000	PC Board
CAPACITORS		
C401	35091-105	470 mf., 25 WVDC, Electrolytic
C402, C403	35091-108	100 mf., 25 WVDC, Electrolytic
C404	35091-106	2.2 mf., 25 WVDC, Electrolytic
C405	35091-110	22 mf., 16 WVDC, Electrolytic
DIODES		
D401-D412	36617-000	Silicon Switching: 40 mA., PIV 75, 1N914 Texas Inst. 1N4148
CONNECTOR		
J2	39339-104	9-Pin Receptacle
INTEGRATED CIRCUIT		
Z401	36625-000	Quad Amplifier (Comparator) Motorola MC3301P National Semiconductor LM3900N, LM2900N

Schematic Symbol	NuTone Part No.	Description
RELAYS		
K401	39334-000	SPDT, DOOR American Zettler AZ530-08-1
	39381-000	Alternate
RESISTORS		
R408, R415	33101-105	1M
R416, R418	33101-332	3.3K
R417	33101-472	4.7K
Z402	33041-000	Resistor Pack, Includes R419- R424. All Resistors 1/8 Watt
Z403	33042-000	Resistor Pack, Includes R401- R407. All Resistors 1/8 Watt
TRANSISTORS		
Q401	36613-000	NPN Silicon Motorola MPS A20 Texas Inst. TIS-98
Q402	36606-000	PNP Silicon, Motorola MPS-K71 (Yellow) MPC-A70 (D - 150-000)
INTERCOM SWITCHBOARD ASSEMBLY		
	41538-000	Complete Assembly
	37601-000	PC Board
CONNECTOR		
P3	37603-000	8-Pin Connector/PC Board Assembly
RESISTORS		
R501	33101-470	47
R502	33101-270	27
DIODES		
D501, D508	36549-000	Silicon Rectifier, 1 Amp. DC; 100 PIV, 1N4002
D509	36611-000	Silicon, Zener, 36 V, 1N5258
LAMPS		
VR501-VR504	39163-000	105-125 Vac/dc, G.E. "Glow Lamp" #C2A-T (NE-2H) or Equivalent
SWITCHES		
S501, S508	34618-000	DP3T, Non-Shorting Stackpole SS-93
	34620-000	Alternate
GENERAL PARTS		
	45399-000	Label, FM Ant. Lead
	45407-000	Label, Low Level Output
	46757-000	Label, Instructions
	46374-000	Label, Station Selector Switch Room Designator
	38614-000	Bracket, Top Chassis Retaining
	39410-007	Pin, Chassis Retaining

Schematic Symbol	NuTone Part No.	Description
	21018-000	Solderless Wire Connector
	46646-000	Service Manual
	46648-000	Homeowner's Manual
	46650-000	Installation Instructions (Early)
	46757-000	Installation Instructions (Late)
	1001A-000*	Cover, Control Door Assembly
	1002A-000**	complete with Hinge, Spring
	41542-000*	Front Panel Assembly
	41543-000**	Front Panel Assembly
	39415-000	Hanger Strap, Chassis Support
	31987-000	Hook, Hanger Strap
	36090-000	Speaker, 5-inch, 25-ohm, Voice Coil
	41605-000	Hinge, Stationary Leaf and Pin Assembly (Fasten to Rough-in)
	38626-000	Hinge, Moveable leaf (Fasten to Chassis)
IR-10 ROUGH-IN HOUSING		
	13132-900	Complete Assembly
	39096-000	Antenna Terminal Strip
	46620-000	Caution Label
	08525-000	Power Transformer, 16V, 15VA (NuTone 105-N)
	40072-000	FM Antenna Assembly
	29911-000	Transformer, 230Vac Primary (EXPORT ONLY) (X-302-N)
	40674-000	Frame Assembly
IC-31 REMOTE CONTROL		
	13655-900	Complete Assembly
	38559-000	Control Insert
	38571-000	Bezel
C1	35068-104	30 mf., 30 WVDC, Electrolytic
R1	33101-102	1K
R2	33101-822	8.2K
R3	34063-000	200 ohm, Wire Wound Potentiometer, VOLUME CONTROL
S1	39433-051	Contact Wire I/P TALK
	39401-051	Contact
	39432-051	Contact
S2	39435-051	Contact Wire DOOR TALK
	39401-051	Contact
	39432-051	Contact
S3	30570-051	Contact Wire DOOR LISTEN
	39401-051	Contact
	39343-000	Pushbutton
	39344-000	Knob, VOLUME CONTROL

Schematic Symbol	NuTone Part No.	Description
IS-35 INSIDE 5-INCH SPEAKER WITH CONTROLS		
	13695-900	Complete Assembly
	38527-000	Speaker Panel
	36090-000	Speaker, 5-Inch, 25-ohm Voice Coil
C1	35068-104	30 mf., 30 WVDC, Electrolytic
R1	33101-102	1K
R2	33101-822	8.2K
R3	34063-000	200 ohm, Wire Wound Potentiometer, VOLUME CONTROL
S1	39433-051	Contact Wire I/P TALK
	39401-051	Contact
	39432-051	Contact
S2	39435-051	Contact Wire DOOR TALK
	39401-051	Contact
	39432-051	Contact
S3	39436-051	Contact Wire DOOR LISTEN
	39401-051	Contact
	39343-000	Pushbutton
	39344-000	Knob, VOLUME CONTROL
IS-37 INSIDE 5-INCH SPEAKER/ CLOCK TIMER WITH CONTROLS		
	13700-900	Complete Assembly
	41581-000	Front Panel Assembly
	38609-000	Grille, Speaker
	39331-000	Nameplate
	38610-000	Lens
	46693-000	Information Label
	36090-000	Speaker, 5-inch, 25-ohm Voice Coil
	41596-000	Control Assy (Intercom)
	38624-000	Control Insert
R1	35068-104	30 mf., 30 WVDC, Electrolytic
R2	33101-102	1K
R3	33101-822	8.2K
R3	34063-000	200 ohm, Wire Wound Potentiometer VOLUME CONTROL
S1	39433-051	Contact Wire I/P TALK
	39401-051	Contact
	39432-051	Contact
S2	39435-051	Contact Wire DOOR TALK
	39401-051	Contact
	39432-051	Contact
S3	38570-051	Contact Wire DOOR LISTEN
	39401-051	Contact
	39343-000	Pushbutton
	39344-000	Knob, VOLUME CONTROL

Schematic Symbol	NuTone Part No.	Description
CLOCK TIMER PROTECTION CIRCUIT		
	41600-000	Complete Assembly
	37614-000	PC Board
C31	35100-127	.1 mf., 100 WVDC
D31	36549-000	Silicon Rectifier, 1 Amp. DC: 100 PIV, 1N4002
J31	39421-000	Jack, 3-Pin Connector
P31	41601-000	Plug, 3-Pin Connector Complete Assembly
R31	33101-103	10K
R32	33101-223	22K
R33	33101-222	2.2K
VR31, VR32	39163-000	Lamp, 105-125 Vac/dc, G.E. "Glow Lamp" No. C2A-T (NE-2H) or Equivalent
CLOCK & CONTROL CIRCUIT		
	36094-000	Digital Clock Assembly
	38611-000	Ground Strap
	32603-000	Interlock Plug-Cord
	17351-000	End Connector
	39407-000	Knob, MODE SWITCH, TIME/ALARM SET
R21/VR21, R22/VR22	39405-000	Resistor 10K and Lamp Assembly, G.E. D-2A, 105-125 Vac, 2.6 ma, 1/3 watt
	41582-000	Lamp/Resistor Assembly Complete
IS-38 INSIDE 8-INCH SPEAKER WITH CONTROLS		
	13705-900	Complete Assembly IS-38D
	13707-900	Complete Assembly IS-38L
	38532-000	Speaker Panel IS-38D
	38533-000	Speaker Panel IS-38L
	36089-000	Speaker, 8-inch, 25-ohm Voice Coil
C1	35068-104	30 mf., 30 WVDC, Electrolytic
R1	33101-102	1K
R2	33101-822	8.2K
R3	34063-000	200 ohm, Wire Wound Potentiometer VOLUME CONTROL
S1	39433-051	Contact Wire I/P TALK
	39401-051	Contact
	39432-051	Contact
S2	39435-051	Contact Wire DOOR TALK
	39401-051	Contact
	39432-051	Contact
S3	39436-051	Contact Wire DOOR LISTEN
	39431-051	Contact
	39343-000	Pushbutton
	39346-000	Knob, VOLUME CONTROL, IS-38D
	39380-000	Knob, VOLUME CONTROL, IS-38L

Schematic Symbol	NuTone Part No.	Description
IS-61 BUILT-IN DOOR SPEAKER		
	13747-900	"B" Unit Assembly,
	8454-019	Panel
	41327-000	Mounting Panel Assy (Includes Speaker)
	38391-000	Panel, Speaker Mounting
	36076-000	Speaker 3½ Inch, 16-ohm, Weatherproof cone
IS-63 SURFACE MOUNT DOOR SPEAKER		
	13751-900	Door Speaker Assembly
	36076-000	Speaker 3½ Inch, 16-ohm, Weatherproof cone
	32268-000	Mounting Plate
	38324-000	Nameplate
IS-64 SURFACE MOUNT DOOR SPEAKER WITH PUSHBUTTON		
	13753-900	Door Speaker Assembly
	36076-000	Speaker 3½ Inch, 16-ohm, Weatherproof cone
	32268-000	Mounting Plate
	38359-000	Switch Insert
	39280-000	Pushbutton Complete
IS-65 BUILT-IN DOOR SPEAKER		
	13755-900	Door Speaker Assembly
	36076-000	Speaker 3½ Inch, 16-ohm, Weatherproof cone

Schematic Symbol	NuTone Part No.	Description
IS-77 OUTSIDE WEATHERPROOF SPEAKER		
	13780-900	Complete Assembly
	38423-000	Outdoor Speaker Housing
	36074-000	Speaker, Polyurethane, Weatherproof, 16-ohm, 20-watt Peak, Ceramic Magnet
	41835-000	Hanger Bracket Assembly Complete
	38424-000	Connecting Strap
	39267-000	Rushing
	39297-000	Spacer
	38447-014	Mounting Bracket
	41365-000	Hanger Bracket Assembly
	38427-014	Hanger Bracket
	38425-000	Grille
	38599-000	Nameplate
	31128-000	Solderless Wire Connector
IS-78 INSIDE METAL FRAME SPEAKER		
	13782-900	Complete Assembly
	32180-008	Panel
	32181-032	Panel Back
	36089-000	Speaker, 8-inch, 25-ohm Voice Coil
	46665-000	Model Label
IS-79 OUTSIDE METAL FRAME SPEAKER		
	13784-900	Complete Assembly
	32180-008	Panel
	32181-032	Panel Back
	36074-000	Speaker, Polyurethane, Weatherproof, 16-ohm, 20-watt Peak, Ceramic Magnet
	46668-000	Model Label

LIMITED WARRANTY

NuTone, Hallmack, and Mercury by NuTone products are warranted to be free from defects in material and workmanship for the "Warranty Period" which is (a) five (5) years from date of original manufacture in the case of Motors employed in all NuTone Paddle Fans; and (b) five (5) years from date of original manufacture for NuTone Hairdryers, provided, however, this warranty as to Hairdryers shall only be effective provided that (1) NuTone installation instructions are followed exactly and (2) the Hairdryer is installed in a private home or residence for the exclusive use of one family (as opposed to installation in a commercial establishment, hotel, motel, dormitory, or other non-private homes or residence); and (c) twelve (12) months from date of original installation in the case of all other NuTone, Hallmack, and Mercury by NuTone products. Light bulbs, dial lights, record changer needles, batteries (with the exception of those specifically designated as rechargeable), the glass portion of any product, and other consumable items, are not warranted or guaranteed in any manner for any length of time.

Our warranty does not cover damage or failure caused by Acts of God, abuse, misuse, abnormal usage, faulty installation, improper maintenance or any repairs other than those provided by a NuTone Authorized Service Center. There are no obligations or liabilities on the part of NuTone Inc, its divisions or subsidiaries for consequential damages arising out of or in connection with the use or performance of the product or other indirect damages with respect to loss of property, revenues or profit, or costs of removal, installation or reinstallation. All implied warranties with respect to NuTone, Hallmack, and Mercury by NuTone products, including implied warranties for merchantability and implied warranties for fitness, are limited in duration to (a) five (5) years from date of original manufacture in the case of Motors employed in all NuTone Paddle Fans; and (b) five (5) years from date of original manufacture for NuTone Hairdryers, provided however this warranty as to Hairdryers shall only be effective provided that (1) NuTone installation instructions are followed exactly and (2) the Hairdryer is installed in a private home or residence for the exclusive use of one family (as opposed to installation in a commercial establishment, hotel, motel, dormitory, or other non-private homes or residence); and (c) twelve (12) months from date of original installation in the case of all other NuTone, Hallmack, and Mercury by NuTone products.

Some states and provinces do not allow the exclusion or limitation of incidental or consequential damages and some states do not allow limitations on how long an implied warranty lasts, so the above exclusions or limitations may not apply to you.

During the "Warranty Period", NuTone will repair or replace, at NuTone's sole option, free of charge, any defective parts, provided, however, NuTone will not be responsible for and will not pay for any costs or expenses relative to removal or reinstallation of any product or any part of any product after the first twelve (12) months of the "Warranty Period" have expired. Please provide the model number of the product, original date of installation and nature of difficulty being experienced. There will be charges rendered for product repairs made after our "Warranty Period" (as defined above) has expired. This warranty gives you specific legal rights and you may have other rights which vary from state to state and province to province.

For NuTone Customer Service, residents of the contiguous United States should call, Toll Free, 1-800-543-8687

Residents of Alaska, Hawaii and other locations outside the contiguous United States should write to NuTone Inc, Madison and Red Bank Roads, Cincinnati, Ohio 45227 — Attention: Department of National Field Service.

Residents of Canada should write to NuTone Electrical Inc, 2 St. Lawrence Avenue, Toronto, Ontario, Canada M6Z 5T8. (Rev. 10/87)

Product specifications subject to change without notice.

Madison and Red Bank Roads, Cincinnati, Ohio 45227
Printed in U.S.A. Rev. 3/89, Part No. 46646-000