

SERVICE MANUAL

NUTONE MODEL SM-428

BUILT-IN

STEREO RADIO

INTERCOM SYSTEM



NuTone Housing Products

Scovill

Madison & Red Bank Roads, Cincinnati, Ohio 45227

Product specifications subject to change without notice.

Part No. FE985
Printed in U.S.A. 9/77 HI

| CONTENTS | PAGE |
|---|--------------|
| GENERAL | 3 |
| OPERATIONAL CHECKOUT | 5 |
| FIGURE 8: MODEL SM-428 MASTER UNIT FRONT PANEL | 5 |
| FIGURE 9: MODEL SM-428 MASTER UNIT CHASSIS REAR VIEW | 8 |
| FIGURE 10: MODEL ISA-47 5-INCH SPEAKER/CLOCK TIMER FRONT PANEL | 9 |
| THEORY OF OPERATION | 11 |
| POWER SUPPLY MODULE | 11 |
| FIGURE 11: SCHEMATIC DIAGRAM/VOLTAGE CHART/PC BOARD LAYOUT | 11 |
| AM/FM TUNER MODULE | 12 |
| FIGURE 12: SCHEMATIC DIAGRAM/VOLTAGE CHART | 13 |
| (4) FM SQUELCH CONTROL R315: | 14 |
| FIGURE 15: PC BOARD LAYOUT | 15 |
| AM ALIGNMENT | 18 |
| FIGURE 16: DIAL CORD INSTALLATION | 18 |
| FM ALIGNMENT | 19 |
| FM MULTIPLEX DECODER MODULE | 20 |
| FIGURE 17: SCHEMATIC DIAGRAM/VOLTAGE CHART/PC BOARD LAYOUT | 21 |
| DUAL AUDIO PREAMP & INTERCOM PREAMP MODULE | 22 |
| FIGURE 18: SCHEMATIC DIAGRAM/VOLTAGE CHART | 24 |
| FIGURE 19: PC BOARD LAYOUT | 25 |
| POWER AMPLIFIER MODULE | 28 |
| FIGURE 20: SCHEMATIC DIAGRAM/VOLTAGE CHART/PC BOARD LAYOUT | 29 |
| CONTROL MODULE | 31 |
| FIGURE 21: SCHEMATIC DIAGRAM/VOLTAGE CHART/PC BOARD LAYOUT | 33 |
| MASTER UNIT TERMINAL BOARD/REMOTE COMPONENTS WIRING | 34 |
| INTERCOM OPERATION | 35 |
| SYSTEM SERVICING | 39 |
| DISASSEMBLY | 39 |
| TROUBLE SHOOTING | 41 |
| REPLACEMENT PARTS LIST | 43 |
| FIGURE 22: PARENT BOARD—REAR VIEW FOIL PATH/COMPONENTS CONNECTION | 45/46 |
| FIGURE 23: PARENT BOARD—FRONT VIEW FOIL/PATH COMPONENT LOCATION | 47/48 |
| FIGURE 24: NUTONE MODEL SM-428 STEREO RADIO/INTERCOM SCHEMATIC DIAGRAM | 52/57 |

GENERAL

- (1) Stereo LEFT channel = channel A.
 - (2) Stereo RIGHT channel = channel B.
 - (3) When SM-428 Master Unit's MONO/STEREO MODE switch is in MONO position, the two audio channels are combined and the composite signal is fed to all speakers.
 - (4) There are no speakers in the Model SM-428 Master Unit.
 - (5) Monaural inside/patio speakers are connected to channel A.
 - (6) Stereo inside/patio speaker controls are connected to channel A and channel B.
 - (7) When an intercom call is made, both entertainment program channels are silenced by the Master Unit's automatic muting circuit. The intercom signals are fed through channel A amplifier in order to drive the speakers that are connected to channel A power amplifier's output.
- (8) INSTALLATION:**
- (8.1) All components must be installed in com-

pliance with the Installation Instructions supplied therewith.

(8.2) The recommended NuTone wire and cable or engineering equivalent must be used.

(9) The complete system schematic is shown on the back fold-out pages of this manual. Individual module schematics and PC layouts are shown with their respective sections in the THEORY OF OPERATION.

(9.1) The same reference numbers are used in the schematic diagrams and on the PC boards.

(10) Always refer to the REPLACEMENT PARTS LIST in this manual for complete description of the individual components. Use the Part Numbers shown in this list when ordering parts from NuTone.

(11) When repairing and/or replacing components on the PC boards, standard precautions should be observed. Do not overheat the boards, foil paths nor components. When removing components from PC board, use a "Solder sucker" tool to remove melted solder.



**MODEL ISA-45 MONAURAL 5-INCH SPEAKER
(WITH CONTROLS)**

FIGURE 1

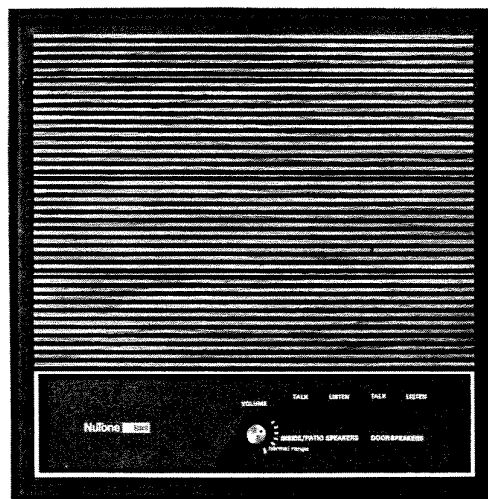

**MODEL ISA-48 MONAURAL 8-INCH SPEAKER
(WITH CONTROLS)**

FIGURE 2

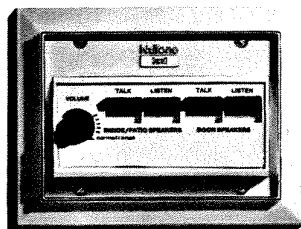

MODEL SR-42 REMOTE STEREO SPEAKER CONTROLS

FIGURE 3

USE WITH
SS-40 DELUXE 8-INCH SPEAKERS
SS-48 BUILT-IN 8-INCH SPEAKERS
IS-78 INSIDE METAL FRAME SPEAKERS
IS-79 OUTSIDE WEATHER PROOF METAL FRAME SPEAKERS
IS-77 OUTSIDE WEATHER PROOF SURFACE MOUNT SPEAKERS

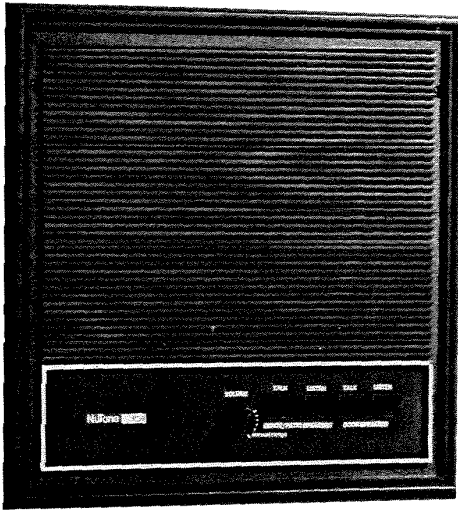

**MODEL SS-48c 8-INCH SPEAKER
(WITH STEREO CONTROLS)
(USE WITH SS-48)
FIGURE 4**

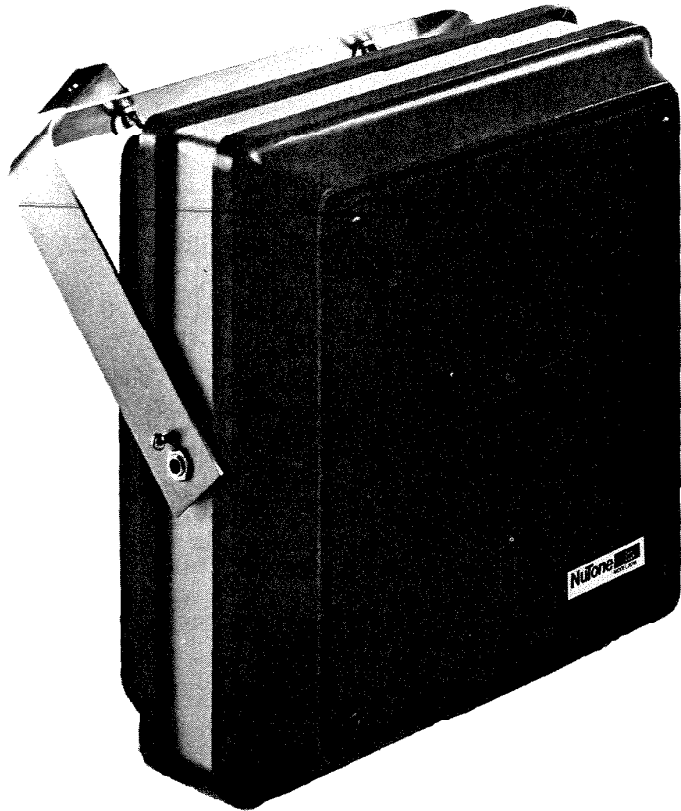

**IS-77 OUTSIDE WEATHER PROOF
SURFACE MOUNT SPEAKER
FIGURE 6**

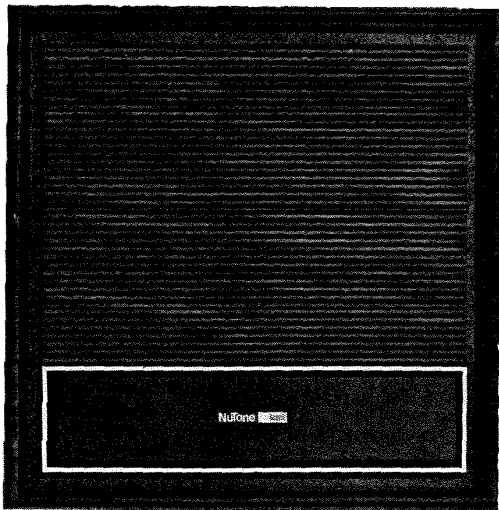

**MODEL SS-48 8-INCH SPEAKER
FIGURE 5**

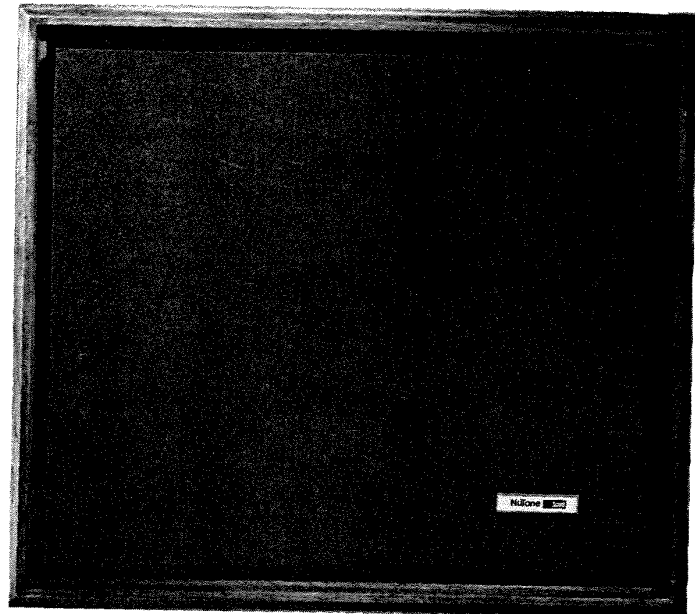

**SS-40 DELUXE 8-INCH SPEAKER
FIGURE 7**

OPERATIONAL CHECKOUT

THE SYSTEM MUST BE CAPABLE OF COMPLETING THE ENTIRE CHECK-OUT PROCEDURE. FAILURE TO COMPLETE ANY STEP INDICATES A MALFUNCTION IN ONE OR MORE OF THE SYSTEM'S COMPONENTS AND/OR THAT THE EQUIPMENT OR WIRING HAS BEEN IMPROPERLY INSTALLED. (SEE TROUBLE SHOOTING SECTION.)

BEFORE ATTEMPTING TO SERVICE THIS SYSTEM, THE TECHNICIAN SHOULD BE COMPLETELY FAMILIAR WITH THE "THEORY OF OPERATION."

ALL CONTROLS AND THEIR OPERATING FUNCTIONS ARE EXPLAINED COMPLETELY IN THE SECTION PERTAINING TO THE MODULE ON WHICH THEY ARE INSTALLED IN THE "THEORY OF OPERATION."

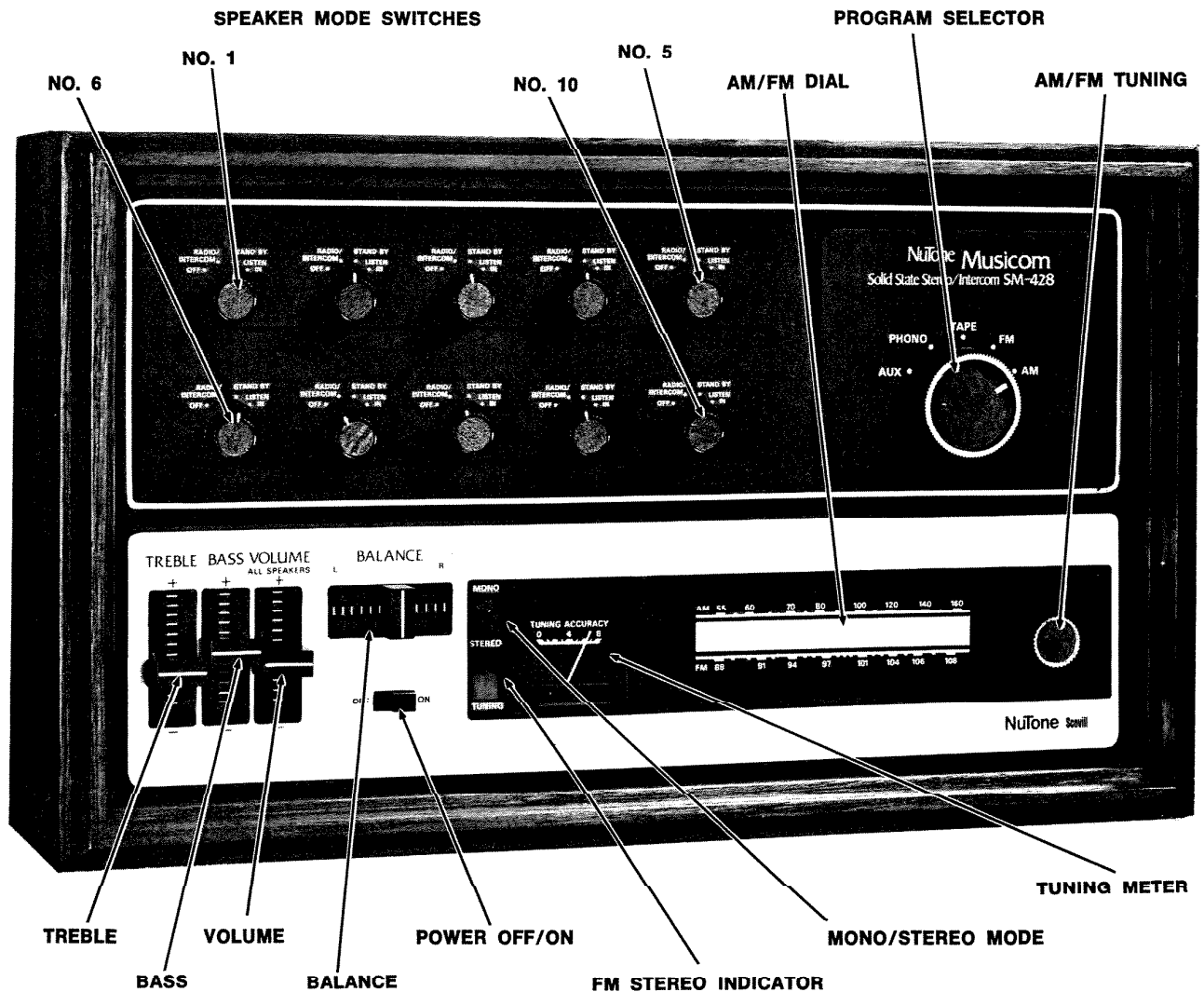

MODEL SM-428 MASTER UNIT

FIGURE 8

(1) Set volume control at every speaker station to maximum, i.e. full clockwise position. Note, there is no speaker in the SM-428 Master Unit.

(1.1) There is one volume control at each monaural speaker control (channel A).

(1.2) There are two volume controls at each stereo speaker control (channel A and channel B). These controls are mounted concentrically.

(1.2.1) The outer knob (ring) controls the level of the channel A speaker.

(1.2.2) The inner knob controls the level of the channel B speaker.

(1.3) There are no volume controls at the door speaker(s).

(2) If the ISA-47 Speaker/Clock Timer is included in the system, make certain that its MODE switch is in the ON position.

(3) AT THE SM-428 MASTER UNIT:

(3.1) Set the BASS and TREBLE controls to their approximate mid-range position. After initial checkout is completed, the controls may be adjusted to the setting that pleases the listener.

(3.1.1) To increase bass and treble response, slide the respective control up; to decrease response, slide the control down.

(3.1.2) The system incorporates individual potentiometers for controlling the bass and treble in each channel. The respective controls are connected in tandem by the knob and the bass and treble is varied in both channels when the respective knob is adjusted.

(3.2) Set the BALANCE control in its mid-range position. This control incorporates an individual potentiometer in each channel. The potentiometers are reverse connected and adjusted in tandem so that when the resistance of one increases, the resistance of the other decreases. (See paragraphs (12.5.1) and (12.5.2), page 23.

(3.2.1) When the BALANCE control is moved to the left—from center position, channel B's volume decreases. (Channel A's volume will increase, but increase is so small—less than ½ db from 50% to 100% of its travel—that its increase may not be discernible.)

(3.2.2) When control is moved to the right, channel A's volume decreases. (Channel B's volume will increase, but as noted above, increase may not be discernible.)

(3.3) Set SPEAKER OPERATING MODE switches, 1 through 10, to RADIO INTERCOM position.

(3.4) Set the tandem VOLUME ALL SPEAKERS control to minimum (down) position. The audio output of both amplifiers should be zero.

(3.5) Set PROGRAM SELECTOR switch to FM.

(3.6) Throw POWER ON/OFF switch to ON. The lights behind the AM/FM TUNING DIAL and the light behind the TUNING ACCURACY METER should be turned ON.

(3.7) When PROGRAM SELECTOR switch is in AM or FM and power is applied to the set, the TUNING METER will indicate the presence of a very low level signal even if the radio is NOT tuned to a station. This is caused by the r-f noise that is picked up by the receiver.

(3.7.1) When PROGRAM SELECTOR switch is in any other setting, the TUNING METER will read zero.

(3.8) While observing the FM (lower) dial scale, rotate the TUNING KNOB and tune to a familiar

FM broadcast station. Tune for maximum reading on the TUNING METER.

(3.8.1) If the FM station is broadcasting in stereo, the STEREO indicator light will be turned ON.

(3.8.2) Depending on whether the station is broadcasting in stereo or monaural, the integrated circuit (IC) that is used for FM multiplex decoding will automatically switch between stereo and monaural operation.

(3.8.3) When stereo FM is received, the left stereo program will be amplified through channel A, and the right stereo program will be amplified through channel B.

(3.8.4) When monaural FM is received, the monaural program will be amplified by both channel A and channel B amplifiers, and the identical program sent to all speakers.

(3.8.5) When sufficient FM signal is received (and the squelch control on the AM/FM Tuner Module is correctly set), the sideband noise that is typically present with limiter-discriminator FM operation is eliminated. The set will be quiet when tuned between FM stations and tuning is as easy and unambiguous as in an AM receiver — without resorting to AFC. (See AM/FM TUNER MODULE, THEORY OF OPERATION, below.)

(3.9) Adjust the VOLUME ALL SPEAKERS control so that there is sufficient volume in the locale requiring the greatest audio level. This should assure sufficient volume at all speaker stations.

(4) ADJUST VOLUME AT EACH SPEAKER STATION.

(4.1) STEREO SPEAKERS:

(4.1.1) At each stereo station's speaker control (SR-42 or SS-48C) adjust the concentric (channel A and channel B volume controls) for the desired audio level in that locale. To achieve proper audio balance, one control may be set slightly higher than the other.

(4.1.2) Since the audio level from the SM-428 Master Unit amplifiers is great enough for the locale requiring the greatest level (paragraph (3.9) above), the other stations will probably require slight attenuation of the audio signal by turning the controls counter clockwise.

(4.3) *To make certain that the audio power output of the amplifiers is used to drive the speakers and not be dissipated in their controls:*

(4.3.1) The VOLUME ALL SPEAKERS control on the SM-428 Master Unit should be set as low as possible — just high enough to assure sufficient volume at locale requiring the greatest audio level. (Paragraph (3.9) above)

(4.3.2) The volume control(s) at the mono and stereo locales should be set as high as possible — attenuated just enough to assure that the audio volume is not too loud at its individual locale.

(4.3.3) This will also help keep distortion at a minimum by preventing the over-driving of the amplifiers.

(4.3.4) If the control at a speaker is set very low in order to attenuate loud audio signals to that speaker, it will also attenuate that speaker's output when it is used to transmit an intercom message and result in low level intercom signals at the receiving speaker stations.

(4.4) The door speakers are not controlled by individual level sets. They are connected direct across channel A's output when receiving, and across the input when transmitting intercom messages. Their mode is determined by the controlling inside/patio speaker.

(5) ADDITIONAL BALANCE ADJUSTMENT:

(5.1) If the audio balance at all stereo speakers is maintained with only a slight difference in the setting of the A and B level set controls, no further adjustment to the SM-428 BALANCE control is required. (See paragraphs (3.2) through (3.2.2) above.)

(5.2) A difference in loading of the power amplifiers, such as would result in a system incorporating five sets of stereo speakers and five monaural speakers (ten speakers connected to channel A; and five speakers connected to channel B), may require readjustment of the balance controls so that the stereo speaker level set controls will more nearly track in unison. Move the BALANCE control on the SM-478 so as to increase the audio power to the weaker speakers.

(6) PHASING STEREO SPEAKERS:

(6.1) In practical application, phasing of the A (left) and B (right) speakers at a stereo locale will have very little audible effect on the mid-range and higher audio frequencies.

(6.2) When the left and right stereo speakers at a locale are in-phase the bass reproduction will sound better than when they are out-of-phase.

(6.3) Tune to an AM station or to a monaural FM station, and with the identical mono program source and the STEREO/MODE switch in STEREO position, listen to the bass response in the stereo locale being checked.

(6.3.1) Transpose the wiring connections at the B channel speaker and again note the bass response.

(6.3.2) Determine whether speakers sounded better in the former or latter and leave wiring at B channel speaker in accordance.

(7) INTERCOM OPERATION.

(7.1) With the exception of the door speakers, all intercom speaker operation is controlled by the INSIDE/PATIO (I/P) TALK and LISTEN switches on the speaker controls. This includes the ISA-47 5-inch Speaker/Clock Timer and the outdoor weather-proof speakers.

(7.2) The Instructions below are presented as checkout procedure for one I/P speaker, but they should be completed, in-turn, at every I/P station in the system.

(7.3) At the speaker control, press down the I/P SPEAKERS TALK switch and talk into the speaker (A channel speaker at stereo locale) in a normal voice.

(7.3.1) When speakers are fed through a remote control, such as a ceiling mounted patio speaker, they will pick up the voice signals from a normal distance.

(7.3.2) The entertainment program — both channel A and channel B — should be silenced at every I/P speaker due to the automatic muting circuit in the SM-428.

(7.3.3) The switching noise that is often associated with switching inputs and outputs in high gain circuits is essentially silenced by the "Key click" muting circuit in the SM-428. It may be noticed, but should not be objectionable, when speakers are switched so as to act as a transmitter (microphone). (See CONTROL CIRCUIT, THEORY OF OPERATION, below.)

(7.3.4) The intercom message should be heard at all other I/P speakers. (All I/P speakers OPERATING MODE SWITCHES should be in RADIO/INTERCOM position as directed in paragraph (3.3) above.)

(7.4) When through speaking, release the I/P SPEAKERS TALK switch.

(7.4.1) The key-clicks will be muted.

(7.4.2) The entertainment programs' muting — channels A and B — will be removed, and the entertainment audio will rise to full level through both channels in approximately one-half second.

(7.5) NOTE: WHEN ANY I/P SPEAKER OR DOOR SPEAKER TALK OR LISTEN SWITCH IS ACTIVATED (PRESSED DOWN) THE ENTERTAINMENT PROGRAM MUTING AND "KEY CLICK" MUTING SHOULD OPERATE AS DESCRIBED ABOVE.

(7.6) Press down the I/P SPEAKERS LISTEN switch. Have another person answer "Hands-Free" from any other I/P speaker. "Hands-Free" answering should be checked from every I/P speaker.

(7.7) Press down the DOOR SPEAKERS TALK switch and talk into the speaker. The message should be heard at the door speaker(s).

(7.7.1) The entertainment program will be muted and the intercom message to the door speaker(s) will be heard at all other I/P speakers.

(7.8) Release the DOOR SPEAKERS TALK switch and press down the DOOR SPEAKERS LISTEN switch. Another person should answer "Hands-Free" from the door speaker(s). The message from the door speaker will be heard at every I/P speaker.

(8) INTERCOM/ENTERTAINMENT LEVEL SET:

(8.1) The SM-428 Master Unit is supplied with the LEVEL SET controls (R617 in channel A, and R640 in channel B) set at maximum.

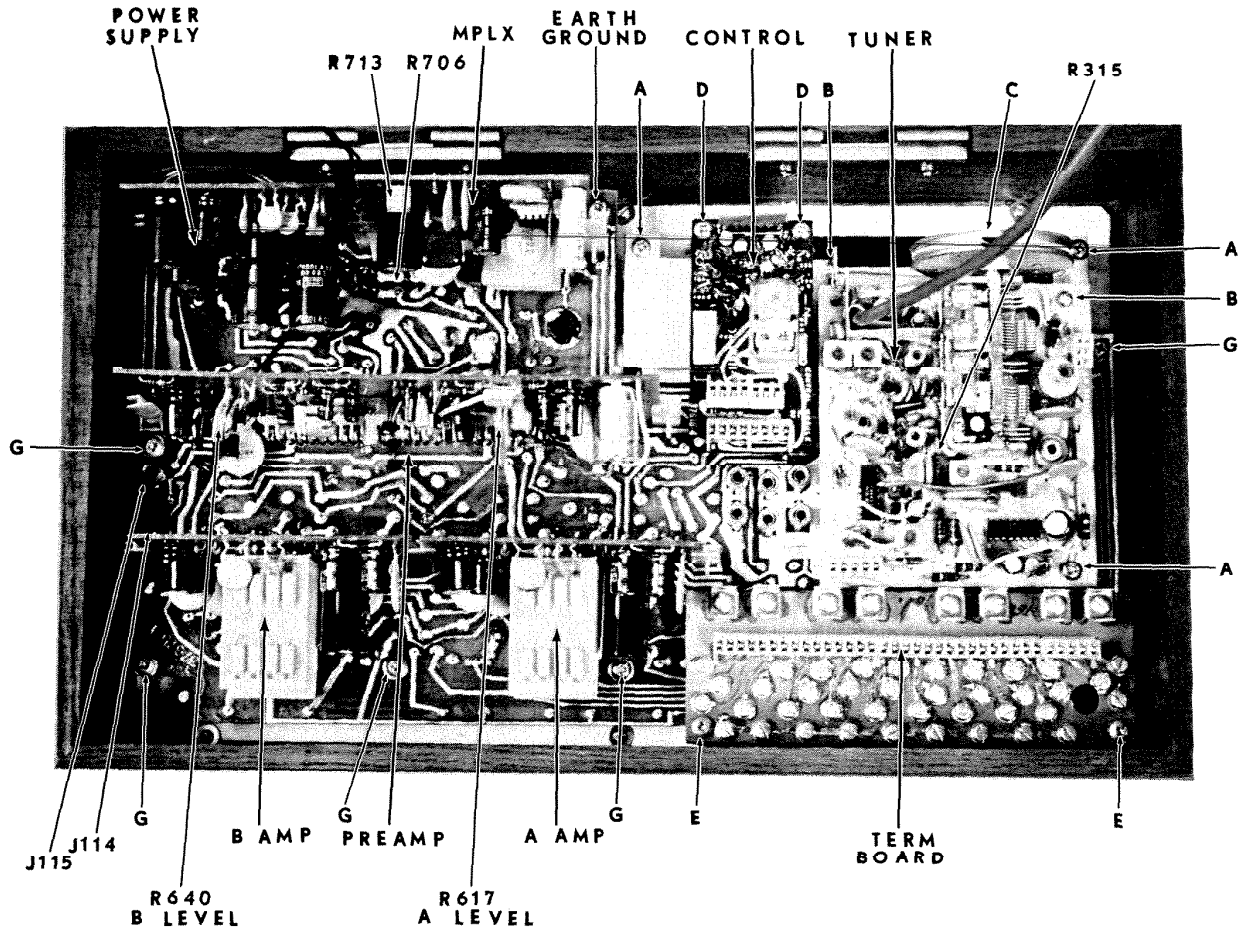

**MODEL SM-428 MASTER UNIT REAR VIEW
(AS VIEWED WHEN INSTALLED)**

FIGURE 9

(8.2) If after completing the checkout procedure above, the intercom signal volume is too low in comparison with that of the entertainment signals:

(8.2.1) While listening to an AM or FM station, lower the volume of the entertainment signals by equally reducing the setting of R617 (A channel) and R640 (B channel) level set controls.

(8.2.2) Increase setting of the VOLUME ALL SPEAKERS control on SM-428 so that the entertainment program at the speaker stations is at the desired level.

(8.2.3) Lowering the setting of the LEVEL SETS R617 and R640 had no effect on the intercom volume, but raising the setting of the VOLUME ALL SPEAKERS control increased the intercom volume as the entertainment program level was brought back to its original volume.

(8.2.4) Slight adjustment of the BALANCE control may be required.

(8.2.5) It may be necessary to make more than one adjustment of the LEVEL SET controls R617 and R640 and of the VOLUME ALL SPEAKERS control to get entertainment program and intercom signals at the exact desired level.

(8.3) If after completing the checkout procedure, the intercom signal volume is too high in comparison with that of the entertainment program:

(8.3.1) Check that LEVEL SET controls R617 and R640 are set at maximum. If not, raise their setting and lower the setting of VOLUME ALL SPEAKERS control.

(8.3.2) If LEVEL SET controls are set at maximum, raise the setting of the VOLUME ALL SPEAKERS control, and at each speaker station control lower the audio level with the volume control.

(8.3.3) Again, setting the volume controls a couple of times, and readjustment of the BALANCE control on the SM-428 Master Unit may be required.

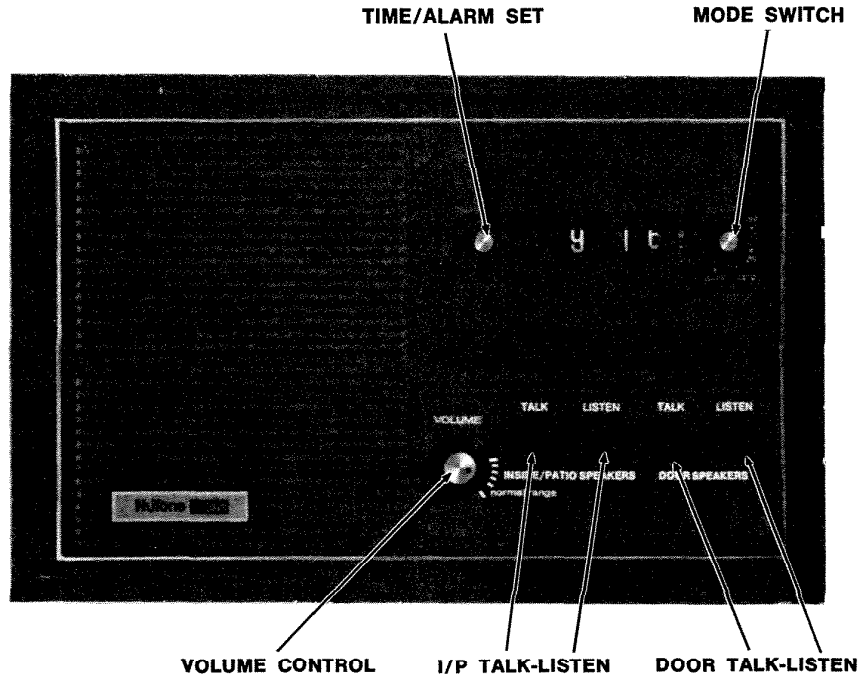

MODEL ISA-47 5-INCH SPEAKER/CLOCK TIMER

FIGURE 10

(8.4) IN ANY CASE, OPERATE THE SYSTEM WITH THE VOLUME ALL SPEAKERS CONTROL ON SM-428 AT THE MINIMUM POSSIBLE SETTING, AND THE VOLUME CONTROLS AT THE INSIDE/PATIO SPEAKERS AT THEIR MAXIMUM POSSIBLE SETTING THAT WILL RESULT IN THE DESIRED LEVEL RATIO. (See paragraphs (4.3) through (4.3.4) above.)

(9) I/P SPEAKERS OPERATING MODE SWITCHES:

(9.1) While carrying out the procedure above, each I/P SPEAKER OPERATING MODE (No. 1 through No. 10) switch should be in the RADIO/INTERCOM position as directed in paragraph (3.3) and their operation be as described above.

(9.2) SPEAKER MODE SWITCH IN OFF POSITION:

(9.2.1) Will not receive entertainment program; will not receive (nor can it answer "Hands-Free") calls originated by other I/P speakers, cannot receive nor transmit signals to door speaker(s); and will not receive chime and/or alarm signals.

(9.2.2) Using its I/P TALK switch, the "Off" speaker can send intercom signals to other I/P speakers that are in RADIO/INTERCOM. There will be no Key-Click nor entertainment program muting.

(9.2.3) Using its I/P LISTEN switch, it will receive "Hands Free" answer from other I/P speakers that are operating in RADIO/INTERCOM or STANDBY mode. There will be Key-Click and entertainment program muting.

(9.3) SPEAKER MODE SWITCH IN STANDBY:

(9.3.1) Speaker has regular intercom operation with other I/P speakers that are in RADIO/INTERCOM or STANDBY; and with door speaker(s).

(9.3.2) Speakers in this mode can not receive entertainment programs nor signals from electronic chimes and/or alarm systems.

(9.4) SPEAKER MODE SWITCH IN LISTEN-IN:

(9.4.1) The speaker will be connected to the input of the intercom preamp and sounds in the vicinity of this speaker will be heard in all other I/P speakers that are in RADIO/INTERCOM MODE.

(9.4.2) The intercom signal from this speaker should over-ride the entertainment program at the other I/P speakers. If not, the intercom level may be increased by increasing the setting of the channel A speaker volume at the speaker station's control.

(9.4.3) The speaker will not be able to receive calls originated by other I/P speakers.

(9.4.4) The speaker operating LISTEN-IN can originate intercom calls with its I/P talk switch, and receive "Hands-Free" answer from other I/P speakers that are in RADIO/INTERCOM or STANDBY MODE.

(9.4.5) The speaker can talk to, but can not hear the door speaker(s).

(10) Any number of I/P speakers can be operated in any MODE at the same time.

(11) ISA-47 5-INCH SPEAKER/CLOCK TIMER:

(11.1) Operation of its VOLUME CONTROL and TALK/LISTEN SWITCHES is the same as that for any I/P speaker.

(11.2) MODE SWITCH OPERATION:

(11.2.1) OFF: Entertainment program is muted through entire system. Its intercom operation is normal as determined by the setting of its SPEAKER MODE switch in the SM-428 Master Unit.

(11.2.2) ON: Full normal operation, determined by the setting of its SPEAKER MODE switch in the SM-428.

(11.3) TIME/ALARM SET CONTROL:

(11.3.1) SETTING TO CORRECT TIME: Push-in and turn in either direction until clock is reading correct time.

(11.3.2) AUTOMATIC/ALARM OPERATION: Set the MODE switch in AUTO or ALARM. Turn TIME/ALARM SET control by rotating in a clockwise direction (the alarm dial will turn counter clockwise) until the alarm dial is set to the time desired for the entertainment program to resume or for the alarm buzzer to be turned ON.

(11.3.3) If the MODE switch is in AUTO and clock has advanced to the alarm set time, muting of the entertainment program will be removed and the music will resume through all speakers in the system that are in RADIO/INTERCOM mode.

(11.3.3.1) For continuous normal radio/intercom operation, the MODE switch should be returned to ON: If not, the entertainment program will be on for approximately 30-minutes and then be automatically muted.

(11.3.4) If the MODE switch is in ALARM and the clock has advanced to the alarm set time, the alarm buzzer will be turned ON, and remain ON for 30-minutes or until the MODE switch is thrown ON. If allowed to run the 30-minutes the buzzer will be turned OFF and the entertainment program remain muted.

(12) SILENT (NIGHT) OPERATION:

(12.1) If an ISA-47 is not included in the system, full intercom operation with the entertainment program silenced may be maintained by throwing each speaker station's SPEAKER MODE switch on the SM-428 Master Unit to STANDBY position; or these switches may be left in the RADIO/INTERCOM position, and the PROGRAM SELECTOR switch set in AUX position — with no program being fed to the auxiliary inputs.

(13) RECORD PLAYER (OPTIONAL): The SM-428 is designed for operation with NuTone built-in automatic record changers, which are connected through shielded audio cables to the LEFT (J109) and RIGHT (J108) PHONO inputs according to the Installation Instructions.

(13.1) Throw the PROGRAM SELECTOR switch on the SM-428 to PHONO position, and operate the

record changer in accordance with its Operating Instructions.

(13.2) If another record player is substituted, it must use a self-equalizing ceramic phonograph cartridge with an output in the order of 300 millivolts.

(14) TAPE PLAYER (OPTIONAL): The SM-428 is designed for operation with NuTone built-in 8-track tape players, which are connected through audio shielded cables to the LEFT (J111) and RIGHT (J110) TAPE input jacks according to the Installation Instructions.

(14.1) Throw the PROGRAM SELECTOR switch on the SM-428 to TAPE position, and operate the tape player according to its Operating Instructions.

(14.2) If another tape player is used, it must have a preamplified output (not power amplified output) in the order of 300-500 millivolts when working into a high impedance input. If the players output is so great as to overload the input of the SM-428, shielded high-resistance (approximately 500K ohms) level-set potentiometers must be installed between the output of the tape player and the TAPE inputs of the SM-428. A separate control must be used in each channel. (These are local purchase items and are not supplied by NuTone.)

(14.2.1) The output of most tape decks is taken direct from the playback heads and can not be used to drive the TAPE input of the SM-428.

(14.2.2) If a tape deck is used, its outputs should be run through a stereo preamp, and the controlled outputs of the preamps fed to the TAPE input of the SM-428.

(15) AUXILIARY INPUT: Audio program source from other equipment may be fed through LEFT (J113) and RIGHT (J112) AUX jacks. The input should be preamplified level — not output of power amplifier. Tape heads and microphones can not be used direct. They must be preamplified. Preamplifiers for this purpose are local purchase items and are not supplied by NuTone.

(15.1) Connect program source through shielded audio cable; operate auxiliary equipment in accordance with its instructions; and throw PROGRAM SELECTOR switch on the SM-428 to AUX position.

(16) TAPE OUTPUT: A preamplified/buffered output of the entertainment program that is selected by the PROGRAM SELECTOR switch is fed to the LEFT (J114) and RIGHT (J115) TAPE OUTPUT jacks in the SM-428.

(16.1) The audio signals to these jacks is essentially "Flat" and is not effected by the LEVEL SET; BASS; TREBLE; BALANCE; and VOLUME controls.

(16.2) The tape output should be connected through shielded cables to the equipment it is to drive. It may be fed to auxiliary amplifiers or to NuTone's Model 516 amplifier for use in background music systems. Follow the auxiliary amplifiers or Model 516 instructions.

THEORY OF OPERATION
(SEE SYSTEM SCHEMATIC DIAGRAM, BACK FOLD-OUT PAGES)

POWER SUPPLY MODULE

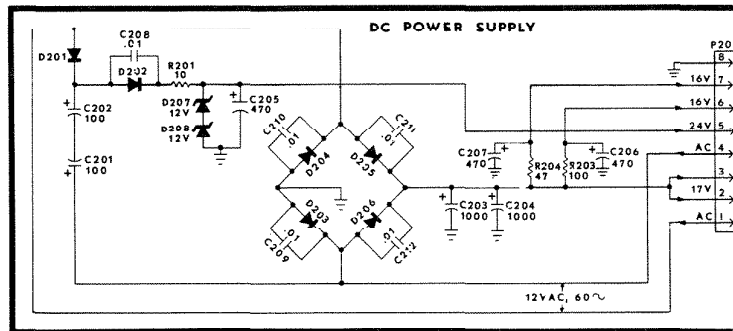

POWER SUPPLY SCHEMATIC DIAGRAM

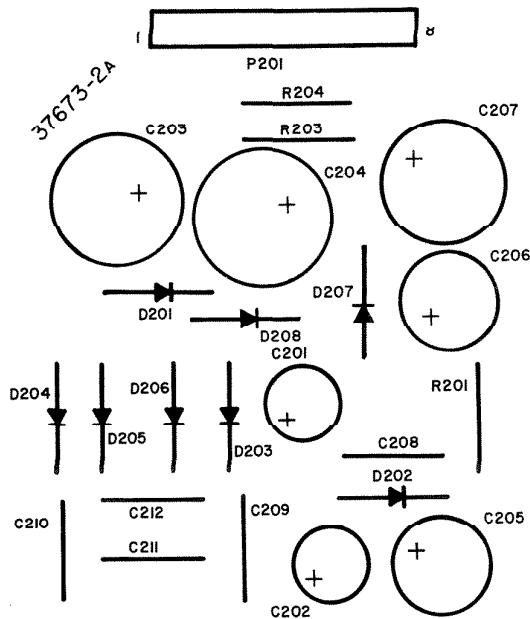

**POWER SUPPLY MODULE
COMPONENT LOCATION-TOP VIEW**

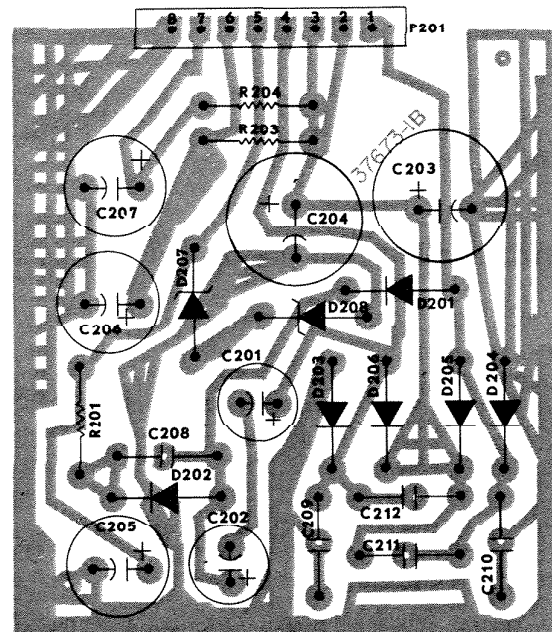

**POWER SUPPLY MODULE — BOTTOM VIEW
FOIL PATH/COMPONENT CONNECTION**

FIGURE 11

(1) The SM-428 Master Unit is powered by 120Vac, 60 Hz., which is fed to the primary of power transformer T101 (NuTone Part No. 42055-000)

(1.1) T101 is installed on a standard octagon electrical box that is located remotely from the Master Unit Rough-in Housing.

(1.2) T101 is a voltage step-down transformer whose secondary is rated at 30VA. With 120Vac to primary, the secondary should be capable of delivering 1.9 Amp DC at 12 Volts. (Secondary should not exceed 15Vac at no load.)

(1.3) The power transformer is protected by a non-replaceable 5 amp fuse in its secondary. If fuse opens, the transformer must be replaced.

(1.4) The secondary 12Vac is connected through two wires to terminals **(M)** and **(I)** on the parent PC board.

(1.4.1) To further protect the transformer one side of the 12Vac line is protected by a 3 amp in-line fuse.

(2) When POWER ON/OFF switch S112 is ON, the AM/FM series connected dial lights I104; I105; I106, and the tuning meter light I101 will be turned ON.

(2.1) When S112 is ON, the 12Vac is connected through J104-1/P201-1 and J101-4/P201-4 to the DC POWER SUPPLY MODULE.

(3) The 12Vac is connected to the half-wave rectifier doubler D201; C201/C202; and D202, whose output is regulated by the two 12V Zener diodes and filtered by C205.

(3.1) The regulated 24Vdc is fed through P201-5/J104-5; across the parent board; and through P104-14/J2B-14 to the CONTROL CIRCUIT MODULE, where it is switched by Q402 in order to power the TALK/LISTEN relay K401.

(3.2) The regulated 24Vdc is also fed from J104-5 through the parent board PC path to input of 12V regulator Z101. The regulated 12Vdc output of the regulator is fed to S111R-6 where it is switched to the FM or AM tuner when the PROGRAM SELECTOR switch S111 is in AM or FM position respectively.

(4) The 12Vac is also fed to the full-wave bridge rectifier D203; D204; D205; and D206, whose 17Vdc output is filtered by C203 and C204.

(4.1) The 17Vdc is fed through P201-2/J104-2 and through P201-3/J104-3.

(4.2) From J104-2 the 17Vdc is fed to one side of the FM STEREO INDICATOR light I102; and through J103-4/P701-4 to power the FM MULTIPLEX DECODER MODULE.

(4.3) From J104-2, the 17Vdc is also fed across the parent PC board; through R123 to terminal (rr) and a yellow wire for use as a muting control voltage with the NuTone Model ISA-47 5-Inch Speaker/Clock Timer.

(4.4) From J104-3, the 17 volts is connected through the parent board PC path to J102-1/P501-1 in order to supply the CHANNEL A AUDIO POWER AMPLIFIER MODULE; and to J101-1/P501-1 in order to supply the CHANNEL B AUDIO POWER AMPLIFIER MODULE.

(5) From the high side (+) of C203/C204, the 17Vdc is fed through R204 and filtered by C207 to supply 16Vdc to P201-7/J104-7.

(5.1) From J104-7, the 16Vdc is fed through J107-27/P602-27 to power the CHANNEL B PRE-

AMPLIFIER; and through P103-15/J2B-15 to power the muting control circuit on the CONTROL CIRCUIT MODULE.

(6) From the high side (+) of C203/C204, the 17Vdc is also fed through R203 and filtered by C206 to supply 16Vdc to P201-6/J104-6.

(6.1) From J104-6, the 16Vdc is fed through J105-6/P601-6 to power the CHANNEL A PRE-AMPLIFIER and the INTERCOM PREAMP.

(6.1.1) R204 (47 ohms) and R203 (100 ohms) are of different value in order to compensate for the difference in the quiescent current of the control circuit and of the intercom preamp. This is done in order to maintain the voltages to the preamplifiers as near equal as possible.

(7) SERVICING THE POWER SUPPLY MODULE:

(7.1) The d-c operating voltages may be checked at the terminals of P201 and/or at the terminals of the other modules.

(7.2) If the d-c voltages are not present at any of the terminals, check for 12Vac between terminals P201-1 and P201-4.

(7.2.1) If the 12Vac is not present, check the 3 amp in-line fuse; power transformer T101; POWER ON/OFF switch S101; wiring; and solder connections.

(7.3) If a short is in one or more of the other modules, the voltage powering that module will be greatly reduced when measured at the terminals of P201/J104.

(7.3.1) To check, remove the suspected module(s) and measure voltages at appropriate terminals of P201/J104.

(7.3.1.1) If voltage is near that indicated in the schematic diagram, check the suspected module(s).

(7.3.1.2) If voltage is still low, check the DC POWER SUPPLY MODULE.

AM/FM TUNER MODULE

(1) When PROGRAM SELECTOR switch S111 is in FM position, the regulated 12Vdc at S111R-6 is connected to S111R-4 and then through P101-3/J1-3 to the FM section of the AM/FM TUNER MODULE.

(1.1) The FM channel A audio is fed from the output of the FM MULTIPLEX DECODER P701-1/J103-1 through S111F-9 and S111F-3 to the input of channel A preamplifier.

(1.2) The FM channel B audio is fed from P701-2/J103-2 through S111R-10 and S111R-12 to the input of channel B preamplifier.

(2) When S111 is in AM position, the regulated 12Vdc at S111R-6 is connected to S111R-5 and

then through P101-2/J1-2 to the AM section of the tuner module.

(2.1) The AM audio is fed from J1-1/P101-1 through S111F-10 and S111F-3 to the input of channel A preamplifier, and through S111R-11 and S111R-12 to the input of channel B preamplifier.

(3) FM TUNER:

(3.1) The FM signal is fed from the antenna, through the coaxial lead-in to the primary of antenna transformer L301. The transformer is center tapped to RF ground through C301.

(3.2) The FM RF amplifier Q301 (Dual-gate MOS-FET) is operated tuned-gate, tuned-drain — resulting in high-gain at low noise.

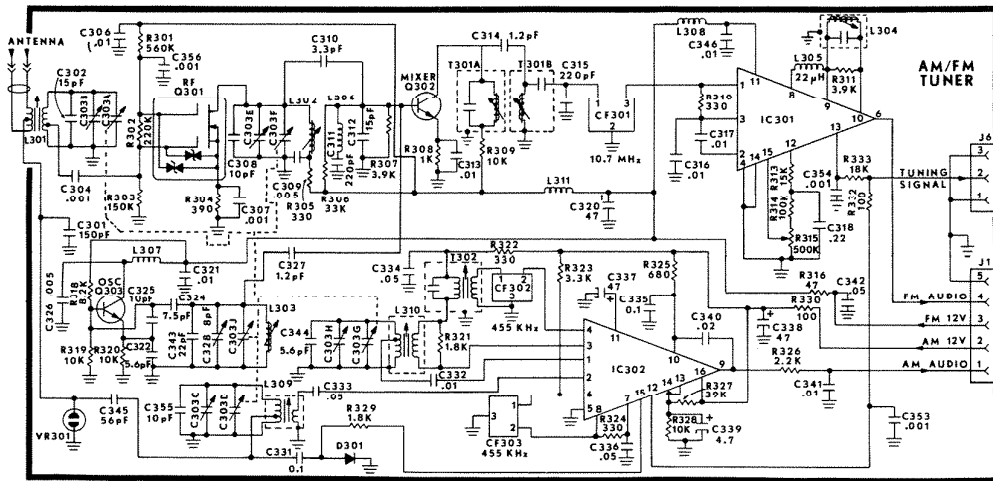

AM/FM TUNER SCHEMATIC DIAGRAM
OPERATING VOLTAGES

WHEN MAKING MEASUREMENTS AT, OR CONNECTIONS TO J1/P101, MAKE CERTAIN THAT THE VOLTAGE SUPPLY TERMINALS J1-2/P101-2 and J1-3/P101-3 ARE NOT SHORTED TO GROUND NOR TO EITHER ONE OF THE SIGNAL TERMINALS J-1/P101-1 AND J1-4/P101-4.

MAKE MEASUREMENTS WITH A HIGH-RESISTANCE INPUT METER SUCH AS A VTVM OR DIGITAL READOUT; OR OSCILLOSCOPE

AM

PROGRAM SELECTOR SWITCH S111 in AM position; tune off station—no signal.
Vcc at J1-2/P101-2 = 12Vdc (regulated)

| DEVICE | PIN NUMBER | | | | | | | | | | | | | | | |
|--------|------------|-----|------|------|---|-----|-----|-----|-----|-----|-----|----|-----|-----|----|------|
| | 1 | 2 | 3 | 4 | 5 | 6 | 7 | 8 | 9 | 10 | 11 | 12 | 13 | 14 | 15 | 16 |
| IC302 | 0.8 | 1.4 | 10.2 | 0.67 | 0 | 8.3 | 1.5 | 1.5 | 0.9 | 5.6 | 0.6 | * | 1.1 | 1.1 | 0 | 11.4 |

NOTE: (*) Tuning Meter Voltage, approximately 0.1V off station depending on received noise, will rise according to signal strength when receiver is tuned to an a-m broadcast station.

FM

PROGRAM SELECTOR SWITCH S111 in FM position; tune off station—no signal.
Vcc at J1-3/P101-3 = 12Vdc (regulated)

| DEVICE | PIN NUMBER | | | | | | | | | | | | | | | |
|--------|------------|-----|-----|---|-----|-----|-----|-----|-----|----|----|----|----|----|-----|----|
| | 1 | 2 | 3 | 4 | 5 | 6 | 7 | 8 | 9 | 10 | 11 | 12 | 13 | 14 | 15 | 16 |
| IC301 | 2.2 | 2.2 | 2.2 | 0 | 2.5 | 5.3 | 7.9 | 5.5 | 5.9 | 6 | 11 | 5 | * | 0 | 4.8 | 0 |

NOTE: (*) Tuning Meter Voltage, approximately 0.1V off station depending on received noise, will rise according to signal strength when receiver is tuned to an f-m broadcast station.

| DEVICE | FUNCTION | ELEMENT | | | |
|--------|-----------------|---------|--------|--------|-----------|
| | | SOURCE | GATE 1 | GATE 2 | DRAIN |
| Q301 | FM RF Amplifier | 1.8 | 1.9 | 3.8 | 9.2 |
| Q302 | FM CONVERTER | EMITTER | | BASE | COLLECTOR |
| | | 0.26 | | 0.94 | 6 |
| Q303 | FM Oscillator | 4.7 | | 6 | 10.43 |

FIGURE 12

(3.3) The FM RF signal is fed through a section of the antenna transformer secondary through C304 to G1 of Q301. The gate tuned circuit is varied by tuning one section of the ganged tuning capacitor C303A. C303B is the high frequency trimmer. Tuning slug in L301 is tuned for low frequency padding.

(3.4) The MOSFET drain is loaded by the tuned RF tank circuit. The tank's resonant frequency is varied by C303F. C303E is high-frequency trimmer and L302 is low-frequency padder.

(3.5) The output of the tank circuit is coupled through C310 to the base of the Mixer Q302.

(3.6) The oscillator Q303 resonant frequency is tuned by C303J. C328 is high-frequency trimmer and L303 is adjusted for low-frequency padding.

(3.6.1) The oscillator frequency should be 10.7 MHz. (the IF frequency) higher than that of the FM RF carrier signal to which the receiver is tuned.

(3.7) The output of the oscillator is coupled through C327 to the base of Mixer Q302.

(3.8) The Mixer Q302 beats the RF and oscillator signals and is loaded by T301A which should be tuned to the 10.7 MHz. IF frequency.

(3.9) For additional selectivity, the output of T301A is coupled through C314 to 10.7 MHz. tuned T301B.

(3.10) The output of T301B is coupled from the high-side of C315 to the Ceramic Filter CF301.

(3.10.1) CF301 is rated at 10.7 MHz. with a 3 db bandwidth of 200-280 KHz.—more than sufficient for the FM broadcast band. The filter has a very high rejection of all other RF frequencies, eliminating the need of additional IF transformers for high-selectivity.

(3.11) The output of CF301 is fed to terminal 1 of IC301.

(3.12) IC301 is a monolithic integrated circuit that provides all the functions of a comprehensive FM IF system, including 3-stage FM IF amplifier/limiter with level detection and an audio amplifier that features use of a noise squelch circuit.

(3.12.1) A complete explanation of this device (RCA's CA3089E) is available in the technical IC literature which is published by the manufacturer.

(3.13) The quadrature detector is tuned by the outboard coil L304.

(4) FM SQUELCH CONTROL R315:

(4.1) The Master Unit is supplied, from the factory, with SQUELCH CONTROL R315 set at maximum position, i.e. with full squelch.

(4.2) When sufficient (normally excess of 5 microvolts) FM broadcast band RF signal is fed to the input of the FM tuner, it will operate with full limiting and the setting of R315 will not effect the quantity nor quality of the recovered audio signal, and the signal-to-noise ratio will be in the order of 45 db. As the input increases, the signal-to-noise ratio will rise to the order of 70 db.

(4.3) When there is sufficient RF signal and the squelch can be operated at maximum, the side-band response that is characteristic of limiter-discriminator FM operation will be eliminated. The set will be quiet when tuned between stations, and the tuning is as easy and unambiguous as in an AM receiver—without resorting to AFC. This eliminates AFC pull from a strong station when attempting to tune to a weak station.

(4.3.1) The FM oscillator in this system has been designed with quality components and by the use of the regulated 12 Vdc supply should be practically free of drift under normal operating conditions and so AFC is not required.

(4.4) When the RF input is below 5 microvolts, due to: distance from transmitter (fringe area): poor receiving antenna; shielded RF area; etc., there may not be sufficient signal to drive the set to limiting, and it will require that the squelch control be set to a lower point.

(4.4.1) This may improve listening satisfaction, but the receiver may be operating at a point where the signal-to-noise ratio has deteriorated and the recovered audio is not acceptable.

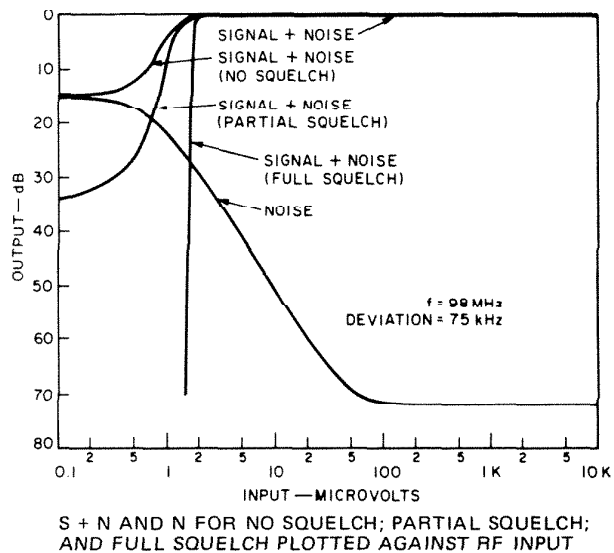
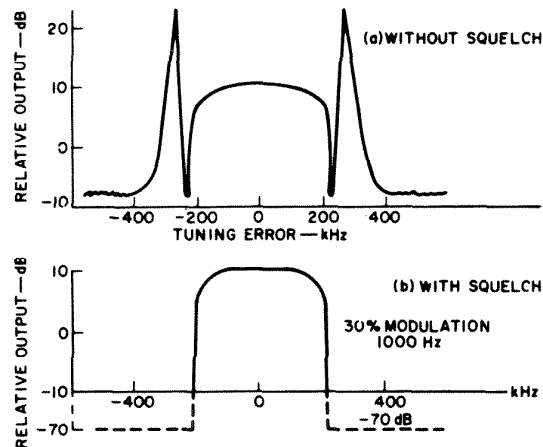

FIGURE 13



TYPICAL TUNING CHARACTERISTIC: (a) WITHOUT SQUELCH; AND (b) WITH SQUELCH, SHOWING THE SUPPRESSION OF SIDE RESPONSE CHARACTERISTIC OF LIMITER - DISCRIMINATOR RECEIVERS

FIGURE 14

(4.5) The magnitude of the squelch control voltage depends only on the signal-to-noise ratio at the tuner input and is essentially independent of the front-end gain because the quadrature signal is fully limited.

(4.6) Adjustment of the SQUELCH THRESHOLD CONTROL primarily changes the degree of noise suppression rather than the threshold. Control R315 is generally operated at maximum value, i.e. full-clockwise as viewed from the FM side of the AM/FM TUNER MODULE.

(4.7) IN THE FIELD ADJUSTMENT OF THE SQUELCH CONTROL R103:

(4.7.1) At the Master Unit, set the VOLUME ALL SPEAKERS control R101/R102; and the volume controls at the I/P speaker stations for normal operation.

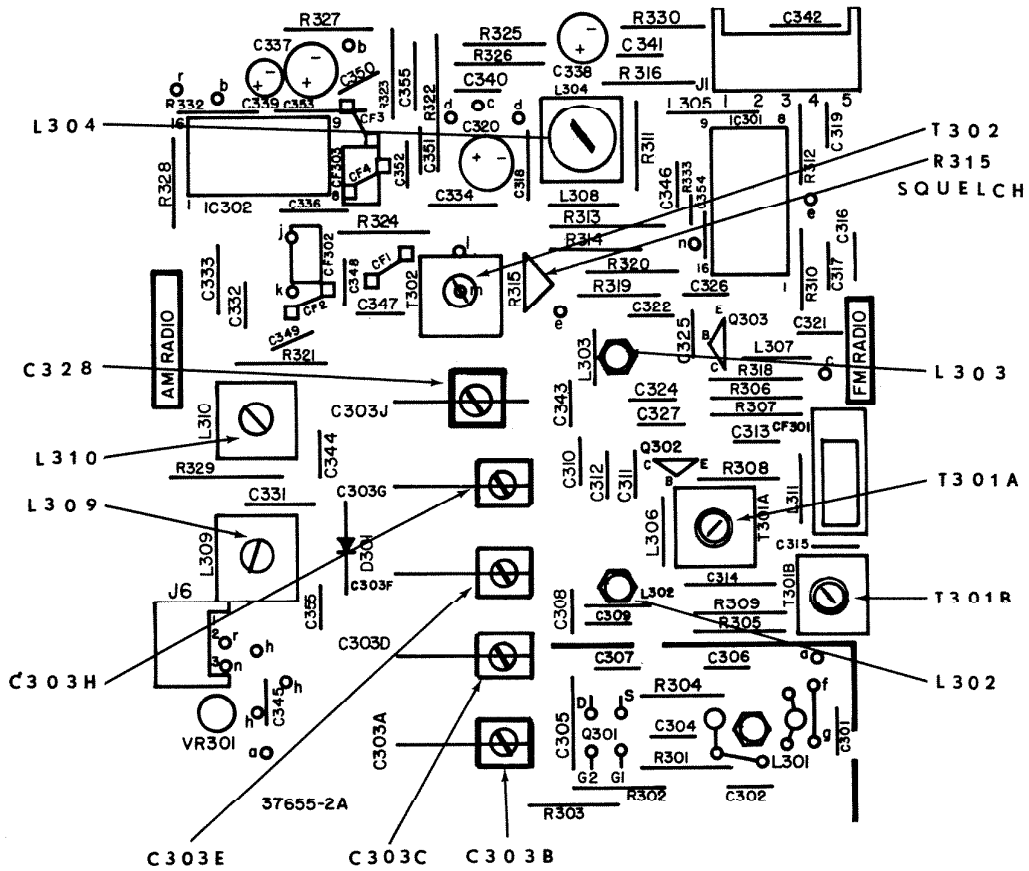

AM/FM MODULE COMPONENT LOCATION-TOP VIEW

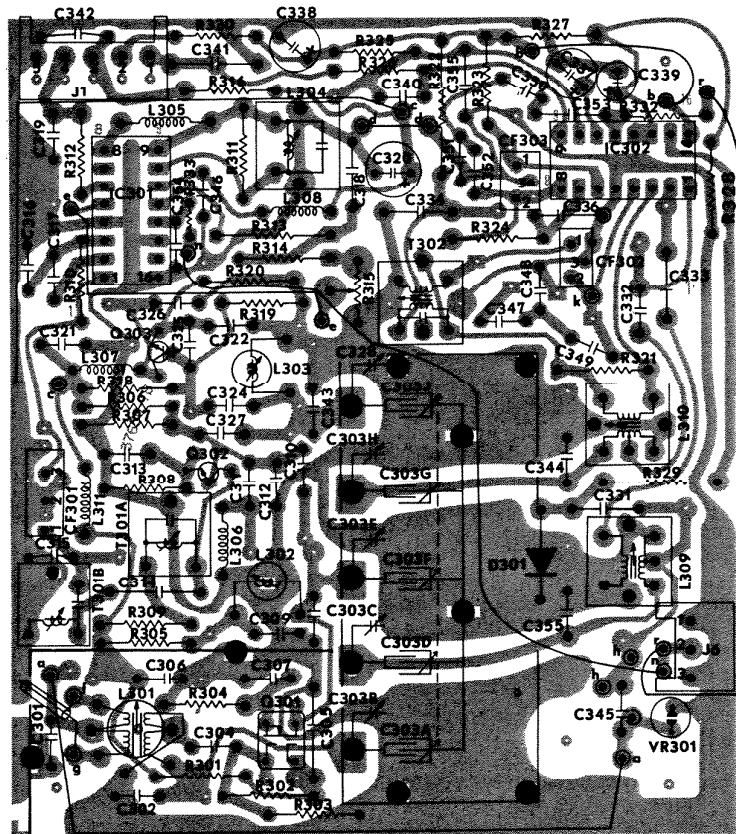

AM/FM MODULE FOIL PATH/COMPONENT CONNECTION-BOTTOM VIEW

FIGURE 15

(4.7.2) Set SQUELCH CONTROL R315 to minimum, i.e. no squelch.

(4.7.3) Tune receiver to weakest FM station that the homeowner may normally be expected to receive.

(4.7.4) If the weak station reception is acceptable, advance the SQUELCH CONTROL R315 until it interferes with reception of the station, then, back the control until reception is acceptable.

(4.7.5) In normal operation, with the FM tuner properly aligned and the received signal too weak to permit full squelch operation, the RF signal input to the receiver should be increased.

(4.7.5.1) This may be accomplished by changing the position of the inside antenna that is supplied with the Master Unit Rough-in Housing; installation of an outside antenna, and if required a directional antenna with an antenna rotor. In some cases increasing height of existing antenna will increase input sufficiently.

(4.7.6) REMEMBER, WITH A PROPERLY ALIGNED FM TUNER, SUB-PAR OPERATION OF THE SQUELCH CIRCUIT IS GENERALLY DUE TO INSUFFICIENT RF SIGNAL INPUT.

(5) As the FM receiver is tuned to the broadcast station, the voltage at IC301-13 will increase in a positive direction. The voltage will be maximum when the receiver is tuned to the exact carrier frequency of the station and will decrease when the receiver is tuned "Off station."

(5.1) The tuning voltage is fed from IC301-13 through R333 and J6-2/P107-2 to the TUNING ACCURACY METER I103. Always tune receiver for maximum indication on the meter.

(6) The recovered audio is fed from IC301-6 through J1-4/P101-4 and J103-5/P701-5 to the FM MULTIPLEX DECODER MODULE.

(6.1) THIS RECOVERED AUDIO SIGNAL IS NOT DE-EMPHASIZED.

(6.1.1) The audio will include both left and right channels and the 19 KHz. pilot tone when the station is broadcasting stereo.

(7) AM TUNER:

(7.1) The AM signal is fed from the center-tap of the antenna transformer L301's primary, through C345 to the tuned AM RF circuit.

(7.2) The RF circuit is tuned by gang capacitor C303D. C303C is the high-frequency trimmer and coupling of L309 is adjusted for low-frequency padding.

(7.3) Delayed AGC is supplied from IC302-15, through R329 and D301 to ground.

(7.3.1) The IC302 includes an audio preamplifier on-board, but in this application its output IC302-15 supplies delayed AGC voltage to the RF tuning circuit.

(7.3.2) With an increase in received signal, the delayed AGC voltage at IC302-15 increases in a positive direction, which increases the current through D301 which will tend to swamp the AM signal.

(7.4) The output of the tuned RF circuit is fed through C333 to IC302-2.

(7.5) IC302 is a monolithic integrated circuit (RCA CA3088E) which provides: AM convertor; IF amplifiers (2-stages) and detector. In this application it also supplies, internal AGC to the first IF stage on-board; delayed AGC to the RF tuned circuit; and tuning voltage to the TUNING ACCURACY METER.

(7.5.1) Complete specifications of the IC's operation can be found in the RCA LINEAR INTEGRATED CIRCUITS MANUAL No. SSD-201C (and subsequent printings).

(7.6) IC302-2 is the base of the oscillator/convertor stage on the IC chip.

(7.7) The oscillator tank is tuned by varying C303G. C303H is the oscillator trimmer and L310 the oscillator collector coupling is adjusted for low-frequency padding.

(7.8) The convertor output IC303-3 is fed to, and tuned by, the 455 KHz. IF transformer T302. The output of T302 is fed through the ceramic filter CF302 to the input of the first IF amplifier stage at IC302-4.

(7.9) The output of the first IF amplifier stage is fed from Z302-6 through the ceramic filter CF303 to the input of the second IF amplifier at IC302-8.

(7.9.1) Second IF amplifier feedback is from IC302-7 through R324 to the input at IC302-8.

(7.10) CF302 and CF303 are ceramic filters, whose center frequency is 455 KHz. ± 2 KHz. with a 3 db band width of 10 KHz. ± 3 KHz. with a frequency stability within 0.4% from -10°C to $+80^{\circ}\text{C}$.

(7.10.1) These ceramic filters provide improved selectivity, while requiring small space with the elimination of the need for additional IF transformers.

(7.11) The internal AGC voltage, which is derived from the on-board detector, varies in amplitude with changes in the received RF signal, and is filtered by C337 at IC302-11.

(7.11.1) The AGC voltage is positive at IC302-11, i.e. at the high side (+) of C337.

(7.12) As the AGC voltage increases, it is inverted on-board and fed to the base of the first IF amplifier—increasing its bias and decreasing its output.

(7.13) The AGC voltage is also fed to another on-board stage, whose "Turn-on" is delayed until the RF signal input to the antenna reaches 100-200 microvolts. When "Turned-on" this delayed AGC is fed from IC302-13 to the input of an on-board amplifier at IC302-14.

(7.13.1) This delayed AGC is amplified and fed from IC302-15 to the RF AGC diode D301, resulting in the swamping action noted in paragraph (7.3.2) above.

(7.14) The positive AGC voltage is also buffered and connected from IC302-12 through R332 and J2/P107-2 to the positive connection of the TUNING ACCURACY METER I103.

(7.14.1) Always tune receiver for maximum indication on the meter.

(7.15) The recovered audio is fed from the on-board detector's output IC302-19, through R326 and J1-1/P101-1 to the left (channel A) and right (channel B) section of the PROGRAM SELECTOR SWITCH on the parent PC board.

(7.15.1) Channel A's AM program is connected from S111F-10 through S111F-3; shielded cable ① to ②; and J105-5/P601-5 to channel A's preamplifier.

(7.15.2) Channel B's AM program is connected from S111R-11 through S111R-12; shielded cable ③ to ④; and J107-28/P602-28 to channel B's preamplifier.

(7.16) The neon lamp VR301 protects the AM and FM front ends from static charges and nearby lightning. It will not protect the set from a direct lightning strike.

(8) ALIGNMENT:

(8.1) The Master Units are shipped from the factory with the AM/FM tuner completely aligned and the FM squelch control R315 set at maximum, i.e. fully squelched.

(8.1.1) Alignment should be checked, and if necessary realignment attempted by qualified personnel ONLY WHEN ABSOLUTELY NECESSARY.

(8.2) The procedure shown on pages 18 and 19 is recommended for "In shop" alignment.

(8.3) The surge impedance (Z_0) of different antennas and their associated transmission lines may vary.

(8.3.1) The antenna transformer L301 must be relatively broad-band to allow for the variations of Z_0 , and when the FM is aligned with the 50 ohm dummy antenna according to the instructions on page 19, it may not exactly match the antenna to the FM RF input.

(8.3.2) If FM signal appears weak when checking the squelch circuit as described in paragraphs (4.7) through (4.7.6) above, it may be possible to increase the input to the RF amplifier Q301.

(8.3.2.1) Tune the receiver to an FM station; and while observing the TUNING ACCURACY meter I103, adjust the tuning slug in L301 for maximum indication on the meter.

(8.3.2.2) Only very slight adjustment should be required, if tuning seems to be too far off, realign according to the instructions on page 19.

(9) SERVICING THE AM/FM TUNER:

(9.1) The operating voltages shown with the schematic Figure 12, page 13, may be checked with the TUNER MODULE installed in the Master Unit and the system operating at its installation.

(9.2) The Radio Assembly, Complete (NuTone Part No. 42004-000) including dial assembly and Tuner PC Module (Part No. 42007-000); or the PC board only may be replaced.

(9.3) To remove Radio Assembly from Chassis:

(9.3.1) Remove AM/FM TUNING KNOB (Figure 8, page 5), pull straight forward.

(9.3.2) Remove two Phillips head mounting screws at top corners of chassis; fold chassis down and support with retainer strap.

(9.3.3) Disconnect shielded antenna lead-in from antenna terminal strip in rough-in housing.

(9.3.4) Remove CONTROL MODULE mounting screws D and gently but firmly lift PC board straight up and away from Master Unit chassis, disconnecting J2A and J2B from P104 and P103. (Figure 9, page 8)

(9.3.5) Remove Radio Assembly mounting screws A and while disconnecting J1 from P101 and J6 from P107, lift Radio Assembly away from Master Unit chassis just far enough to gain access to pilot lights I104, I105, and I106.

(9.3.6) Remove the three lights from the dial frame. (Note: a small screw driver may be needed to gently pry light socket keys out of slots in frame—use care.)

(9.3.7) Lift complete Radio Assembly out of the Master Unit.

(9.4) A replacement Radio Assembly may be installed by reversing disassembly instructions above.

(9.5) The original Radio Assembly may be serviced out of the chassis:

(9.5.1) Connect a regulated 12Vdc supply to terminal J1-2 to check AM; or to terminal J1-3 to supply FM. Connect negative or ground of supply to J1-5.

(9.5.2) The tuner voltages can be checked against Figure 12, page 13; and the alignment checked against that shown on pages 18 and 19.

(9.6) REPLACING TUNER PC BOARD ONLY:

(9.6.1) Disassemble Tuner Assembly as directed in paragraphs (9.3) through (9.3.7) above.

(9.6.2) Set tuning indicator to lowest frequency, i.e. maximum capacity—ganged tuning capacitor C303 fully closed.

(9.6.3) To eliminate the necessity of restringing the dial cord, using masking tape, secure the cord to the capacitor flywheel, at the dial cord pulleys and along the dial frame.

(Text continued on page 20)

FM ALIGNMENT

MASTER UNIT SETTINGS

1. SELECTOR SWITCH S111 in FM position.
2. VOLUME ALL SPEAKERS CONTROL R101/R102 set to desired level.
3. SQUELCH CONTROL R315 (On Tuner Module) set to minimum.

INSTRUMENTS REQUIRED

1. CATHODE RAY OSCILLOSCOPE
 - 1.1 High side of vertical input connected through a 15K ½ watt resistor to tuner's FM audio output J1-4/P101-4.
 - 1.2 Low (ground) side of vertical input connected to Tuner Module ground.
 - 1.3 Use 60 Hz. horizontal sweep. If scope does not have own 60 Hz. horizontal, use exterior source
2. FM SIGNAL GENERATOR
 - 2.1 Modulate RF output with 60 Hz. at 400 KHz. sweep width.
 - 2.2 Connect 60 Hz. to scope's horizontal input if required.
 - 2.3 Connect a 50 ohm resistor across RF output of signal generator
 - 2.4 Connect high-side of generator to center conductor of coax antenna lead-in.
 - 2.5 Connect low-side (ground) from signal generator to shield (braid) of coax.

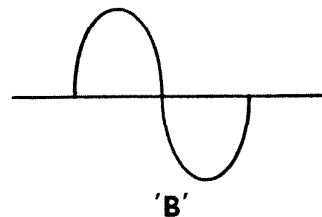
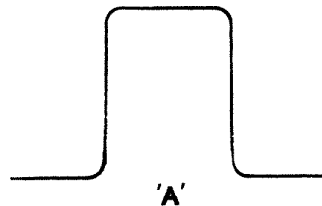

| Step | Signal Generator Setting | Receiver Setting | Adjust | Tune For |
|---|--|--|---|--|
| 1. | 106 MHz. @ 2 to 5 microvolts. (If generator does not have calibrated output, use lowest level consistent with good trace on scope.) | Tune receiver (ganged tuning capacitor to pick up signal generator). | L304 Quadrature coil. Detune coil to get wave form as shown in "A" below. If wave is negative, reverse direction of slug detuning. | Maximum trace on scope as shown in "A" below. Sacrifice gain for linearity and flat top. If necessary, reduce output from signal generator to prevent receiver limiting. |
| 2. | 108.5 MHz. | F.M. Tuning Dial to 108.5 MHz. (Ganged Tuning Capacitor fully opened.) | C328 Oscillator Trimmer | do |
| 3. | | F.M. Tuning Dial to 87.5 MHz. (Ganged Tuning Capacitor fully closed.) | Frequency of RF output from Signal Generator. (Should be in neighborhood of 87.5 MHz.) | do |
| IF, IN STEP 3 ABOVE, FREQUENCY OF SIGNAL GENERATOR IS VERY CLOSE TO 87.5 MHz | | | | |
| 4(a) | 87.5 MHz. | F.M. Tuning Dial to 87.5 MHz. (Ganged tuning Capacitor fully closed.) | L303 Oscillator Coil | do |
| IF, IN STEP 3 ABOVE, FREQUENCY OF SIGNAL GENERATOR IS BELOW 87.5 MHz. (87 MHz or lower) | | | | |
| 4(b) | Slightly decrease the inductance of L303: Turn tuning slug approximately 1/8 turn counter clockwise. Repeat steps 2 and 3 above. | | | |
| IF, IN STEP 3 ABOVE, FREQUENCY OF SIGNAL GENERATOR IS ABOVE 87.5 MHz. (88 MHz. or higher) | | | | |
| 4(c) | Slightly increase the inductance of L303: Turn tuning slug approximately 1/8 turn clockwise. Repeat steps 2 and 3 above. | | | |
| 5. | Repeat 2 and 3 above until oscillator is rocked in at both ends of dial. | | | |
| 6. | 106 MHz. | F.M. Tuning Dial to 106 MHz. | C303B RF Input Transformer 303E RF Output Trimmer T301A and T301B, Mixer 10.7 MHz. IF Output. | do |
| 7. | 90 MHz. | F.M. Tuning Dial to 90 MHz. | L301 Antenna Input Transformer: Two peaks may be noted while adjusting this slug. USE THE PEAK WITH THE SLUG POSITIONED NEAR THE BOTTOM OF THE COIL. L302 RF Amplifier Tank Coil | do |
| 8. | Repeat steps 6 and 7 until no further improvement in scope trace is noted at either setting. As the set is aligned, it may be necessary to reduce output of Signal Generator to prevent receiver limiting. | | | |
| 9. | 90 MHz. @ 10 microvolts. (If uncalibrated, use sufficient signal strength to drive receiver into limiting.) | F.M. Tuning Dial to 90 MHz. | L304 Quadrature Coil. | Maximum symmetrical "S" curve. See "B" below. Curve should be linear and equal distance above and below the reference line on scope. |
| 10. | Step 9 should be checked for various frequencies across the F.M. band. Check limiting by increasing the output of the signal generator, the "S" curve's amplitude should remain the same. | | | |
| 11. | Disconnect signal generator and (if used) external sweep to scope. Scope should use regular horizontal sweep. Tune receiver between stations. Note noise at J/P1-4 (as seen on scope). Turn R315 full clockwise for maximum squelch. Noise should disappear and straight line horizontal trace be seen on scope. | | | |

(9.6.3.1) Be extremely careful, do not distort the dial pointer, nor change its setting.

(9.6.4) Remove the flywheel retainer screw C, bushing, and retainer ring, and slide the flywheel off the capacitor shaft. Secure flywheel to dial frame—do not change its orientation.

(9.6.5) Remove the two PC board-to-dial frame mounting screws B and separate the two assemblies.

(9.7) Install new PC board by reversing above.

(9.8) If desired steps (9.3) through (9.3.7) may be eliminated, if an off-set Phillips head screw driver is available for removing the flywheel retainer screw of paragraph (9.6.4) above.

(9.9) Comparison of the alignment of the old and new AM/FM TUNER MODULES can be made by readings from the TUNING ACCURACY meter I103 with the modules tuned to the same station.

(9.10) If restringing of dial cord is desired, follow diagram, Figure 16, page 18.

FM MULTIPLEX DECODER MODULE

(1) The module board is mounted in the PC card supports with P701 connected to J103 of the parent board.

(2) The decoder is supplied by 17Vdc at J103-4/P701-4, filtered through R714 and C711, from which it supplies base bias to Q702 and Vcc to Z701-1.

(3) The supply is further filtered by R716 and C713, from which it supplies the output terminals Z701-4 and Z701-5 and Vcc to Q701.

(4) The NOT DEEMPHASIZED FM signal—stereo and monaural—is fed from the FM output of the AM/FM TUNER MODULE, through J103-5/-P701-5; R701; and C701 to the audio amplifier Q701.

(5) The amplified FM audio signal (including left and right channels, and pilot tone, when FM stereo signals are received) is coupled through C702 and R706 to the input Z701-2 of the Stereo Demodulator IC.

(6) Z701 (type LM1310) is a monolithic silicon integrated circuit (IC) that is designed for FM stereo demodulation with an automatic internal stereo/monaural switch with a capability of supplying 75 mA for driving the external stereo indicator lamp I102.

(6.1) It has excellent channel separation being typically in the order of 40 db with an input signal of 2.8V (p-p)

(6.2) Its ultrasonic frequency rejection to the output is in the order of 35 db for 19 KHz., and 45 db for 38 KHz.

(6.3) Complete information on the LM1310 may be found in the Motorola and RCA Integrated Circuit Manuals.

(6.4) The optimum alignment procedure, with no input signal applied, is to adjust R713 until 19.00 KHz. is read at Z701-10 on a frequency counter.

(6.4.1) If the receiver is tuned to an FM stereo broadcast station and stereo indicator lamp is not ON: Adjust R713 until the STEREO INDICATOR LAMP I102 is turned ON. To find the center of the lock-in range, rotate the potentiometer back and forth until the center of the lamp "On" range is found.

(6.4.2) If decoder can not be adjusted in this manner, check antenna, receiver alignment, operating voltages etc.

(6.5) When operating FM stereo, the left (A) channel is fed from Z701-4, through 38 KHz. Notch Filter Z702; P701-1/J103-1; shielded cable (h) to (h); and R121 to S111F-9.

(6.5.1) The right (B) channel is fed from Z701-5, through 38 KHz. notch filter Z701; P701-2/J103-2; shielded cable (i) to (i); and R120 to S111R-10.

(6.5.2) Although the demodulator IC has excellent high frequency rejection, the 38 KHz. notch filters are used to protect high-frequency transducers (tweeters) by keeping the 38 KHz. out of the amplifiers; and prevents harmonics from beating with the bias oscillator of tape recorders when program is being taped from the TAPE OUTPUT JACKS J114 and J115.

(6.6) If an FM monaural program is received, the same monaural signal will be fed from outputs Z701-4 and Z701-5 through their respective paths to the PROGRAM SELECTOR SWITCH S111.

(6.7) C705 and R710 in channel A; and C704 and R709 in channel B, form a 13 microsecond deemphasis network. This is less than the normal 75 microsecond deemphasis normally desired with FM reception.

(6.7.1) Further deemphasis is supplied by C635 (channel A) and C634 (channel B) on the DUAL AUDIO PREAMP AND INTERCOM PREAMP MODULE. This is done on order that all audio inputs have the same nominal flat frequency characteristic.

(6.8) When a stereo signal is received the automatic internal switching of the IC connects the stereo lamp indicator pin Z701-6 to ground (saturated collector of on-board NPN transistor).

(7) When Z701-6 is grounded Q702 is saturated and its collector and one side of I102 is grounded. With the other side of the STEREO INDICATOR LAMP connected to 17Vdc, the lamp will be turned ON.

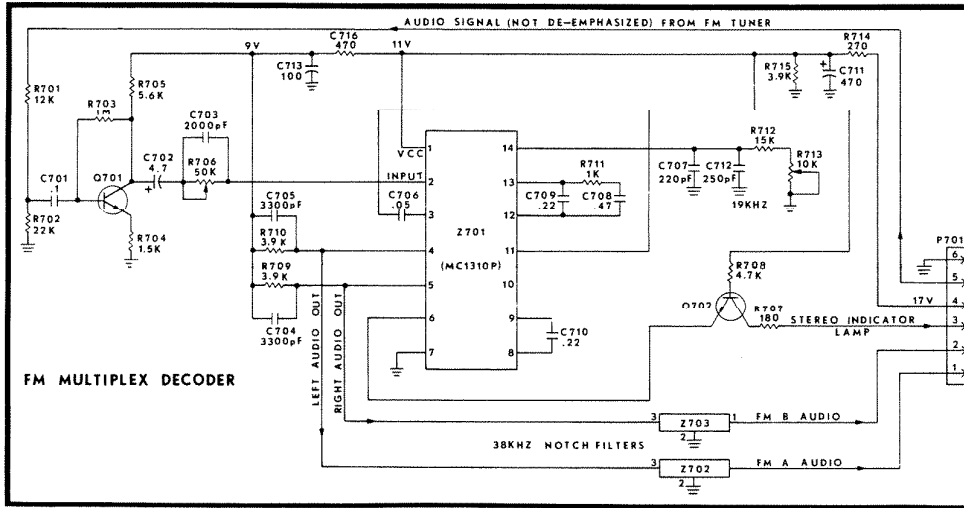

FM MULTIPLEX DECODER SCHEMATIC DIAGRAM

OPERATING VOLTAGES

Vcc at P701-4/J103-4 = 15.1Vdc

| DEVICE | OPERATING CONDITION | PIN NUMBER | | | | | | | | | | | | | |
|--------|---------------------|------------|-----|-----|-----|------|------|---|------|-----------|----|------|------|------|-----|
| | | 1 | 2 | 3 | 4 | 5 | 6 | 7 | 8 | 9 | 10 | 11 | 12 | 13 | 14 |
| Z701 | NO SIGNAL | 10.8 | 2.9 | 5 | 6.8 | 6.8 | 10.4 | 0 | 2.25 | 2.25 | | 2.25 | 2.25 | 2.25 | 3 |
| | FM STEREO | 11.4 | 3 | 5.8 | 6.8 | 6.8 | .913 | 0 | 2.45 | 2.45 | | 2.45 | 2.45 | 2.45 | 3.4 |
| | | ELEMENT | | | | | | | | | | | | | |
| | | EMITTER | | | | BASE | | | | COLLECTOR | | | | | |
| Q701 | NO SIGNAL | 1.6 | | | | 2.18 | | | | 4.7 | | | | | |
| | FM STEREO | 1.4 | | | | 2.01 | | | | 4 | | | | | |
| Q702 | NO SIGNAL | 10.4 | | | | 10.8 | | | | 10.4 | | | | | |
| | FM STEREO | 0.913 | | | | 1.77 | | | | 1.04 | | | | | |

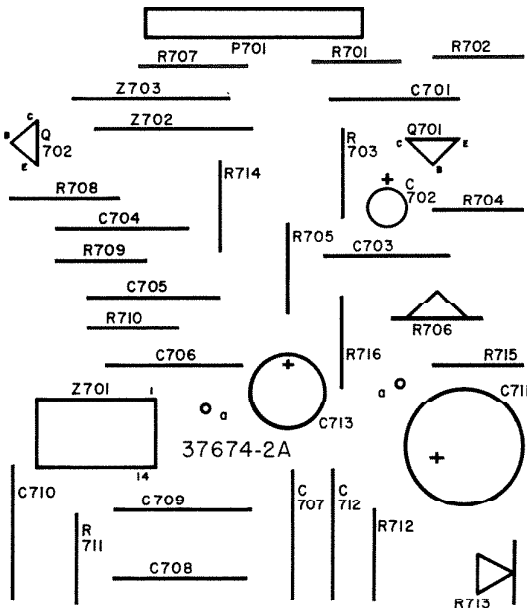

FM MULTIPLEX DECODER MODULE COMPONENT LOCATION-TOP VIEW

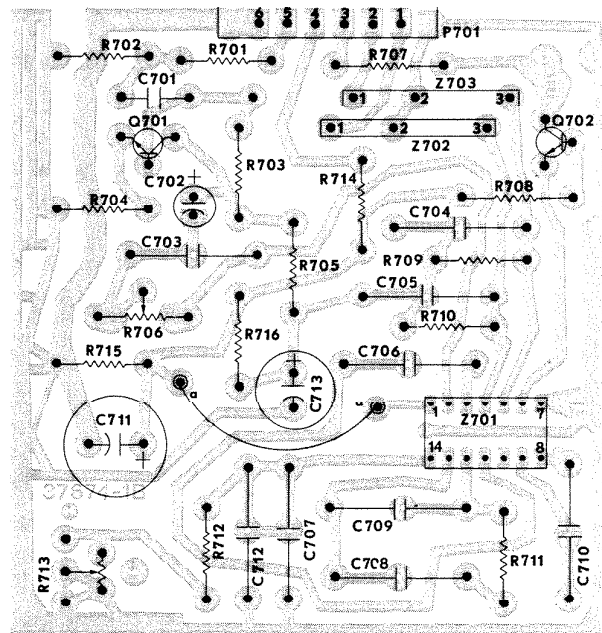

FM MULTIPLEX DECODER MODULE BOTTOM VIEW FOIL PATH/COMPONENT CONNECTION

FIGURE 17

(8) Z701 ALIGNMENT:

(8.1) The oscillator 19.00 KHz. should be set with a frequency counter as described in paragraph (6.4 above); or may be set, using the STEREO INDICATOR LAMP as described in paragraph (6.4.1) above.

(8.2) SETTING INPUT TO Z701-2: The 50 Kohm rheostat R706, in conjunction with C703 controls the phase relationship of the 38 KHz. in respect to the other components of the composite signal which is fed to the input of the decoder.

(8.2.1) With the oscillator at Z701-10 properly set to 19.00 KHz., the channel separation will be equal to or greater than 40db, with a composite signal 0.5V to 2.8V (p-p).

(8.2.2) The IC's on-board stereo switch and lamp control is activated by a d-c voltage in the switch modulator. This d-c voltage is proportional to the received 19 KHz pilot tone.

(8.2.3) Total harmonic distortion (THD) of the IC will vary with composite input level. It will be approximately 0.06% with a composite input level of 0.05V (p-p) and will increase to approximately 0.23% at 2.8V (p-p).

(8.3) The conditions described in paragraphs (8.2.1) through (8.2.3) are well within the specifications for high fidelity stereo FM reception.

(8.3.1) To maintain these specifications, the composite input level should be limited to 2.8V (p-p).

(8.3.2) This input signal may be measured with an oscilloscope.

(8.3.2.1) In practice, tuning to a familiar FM stereo station and setting the control R706 to a level where the pilot tone activates the switch and light and where distortion is not apparent, should suffice for a check.

(9) SERVICING THE MPLX MODULE:

(9.1) Voltage measurements may be made with the module installed in the Master Unit parent board. See voltage chart with schematic diagram, Figure 17.

(9.2) To remove module from parent board, pull straight out—disconnecting P701 from J103.

(9.2.1) When installing module, make certain that all connections are properly made between P701 and J103.

(9.3) BENCH SERVICING: The module may be checked while installed in the Master Unit.

(9.3.1) The module may also be checked independent of the FM tuner and Master Unit.

(9.3.1.1) Connect a variable d-c supply at P701-4 and adjust for 11Vdc at Z701-1. Vcc at high side of C713 should be approximately 9Vdc. Connect ground side to P701-6.

(9.3.1.2) Connect the high side of the composite output of an FM stereo signal generator to P701-5, and the low side to ground P701-6.

(9.3.1.3) The left channel audio output can be measured at P701-1 and the right channel at P701-2.

(9.3.1.4) Measure 19.00 KHz. at pin Z701-10. When composite signal is fed to module, and 19.00 KHz. is properly set, the stereo indicator voltage at P701-3 should be at ground. (If not receiving stereo, or if 19.00 KHz. is not properly tuned, P701-3 will be floating.)

(9.4) Attention is invited to Motorola's Linear Integrated Circuits Manual, Volume 6, Series A, for a detailed description of the operation and test procedure recommended for Z701 (MC1310P).

DUAL AUDIO PREAMP & INTERCOM PREAMP MODULE

(1) The channel A (left) audio preamplifier and the intercom preamplifier are powered by the +16Vdc that is fed from R203 and P201-6/J104-6 of the DC POWER SUPPLY MODULE through J105-6/P601-6 of the PREAMP MODULE.

(2) The channel B (right) audio preamplifier is powered by the +16Vdc from R204 and P201-7/J104-7 of the POWER SUPPLY through J107-27/P602-27 of the PREAMP.

(2.1) This 16Vdc from J104-6 also supplies the CONTROL MODULE through P103-15/J2B-15.

(3) The PREAMP MODULE is connected to circuit ground at P602/J107 terminals 15, 16, and 17.

(4) Channel A's entertainment signals are fed from the front section of PROGRAM SELECTOR SWITCH S111F-3, through shielded cable (f) to (f); J105 5/P601 5; and C606 to the base of Q602.

(5) Channel B's entertainment signals are fed from the rear section of PROGRAM SELECTOR SWITCH S111R-12, through shielded cable (d) to (d); J1-7-28/P602-28; and C617 to the base of Q607.

(5.1) One section of S111R (terminals 4, 5, and 6) is used to switch the regulated 12Vdc to the AM/FM TUNER MODULE, when the switch is in AM or FM position respectively.

(5.2) No voltage is supplied to the TUNER when the switch is in any other position.

(6) The load matching networks—C101/R116 (left PHONO input); and C102/R117 (right PHONO input)—are designed for matching the self-equalizing ceramic phonograph cartridge which is used in NuTone's built-in automatic record player.

(7) The load—C107/R112 (left TAPE input) and C108/R113 (right TAPE input) are designed for use with the preamplified outputs of NuTone's built-in 8-track (4 stereo tracks) tape player.

(8) The partially de-emphasized FM audio signals from the FM MULTIPLEX DECODER MODULE (see paragraphs (6.7) and (6.7.1) under FM MULTIPLEX DECODER MODULE above) are loaded by C103/R121 (left FM input) and C104/R120 (right FM input).

(9) The AM signal from the AM/FM TUNER MODULE is fed direct to the AM input without additional loading.

(10) The four left channel signals are fed individually—depending on the setting of S111F—through C606 with high-frequency roll-off of C634, and they are essentially equal in frequency response and amplitude at base of Q602.

(10.1) The four right channel signals are fed individually—depending on the setting of S111R—through C617 with high-frequency roll-off at C635, and they are essentially equal in frequency response and amplitude at base of Q607.

(11) CHANNEL A: The entertainment program is amplified through Darlington connected Q602 and Q603; and the emitter follower Q604 with an overall gain (V_{out}/V_{in}) of 13.

(11.1) Since the emitter follower Q604 has a gain of slightly less than unity, the actual gain takes place in Q602 and Q603.

(11.2) The emitter output of Q604 is connected through C608; and P601-7/J105-7 to left (A) channel TAPE OUT JACK J114.

(11.2.1) The output at J114 is not effected by the setting of any tone control, nor by the setting of the volume; balance, and level set controls, and thus can be fed to a tape recorder or to another amplifier at a constant level with flat response regardless of the setting of these controls.

(11.3) From C608 the flat audio signal is fed to the high-side of LEFT CHANNEL LEVEL CONTROL R617. From the variable tap of R617 the audio signal is fed through R618; R619; and P601-8/J105-8 to the left (A) channel BASS CONTROL R105.

(11.4) From the variable tap of R617 the flat audio signal is fed through R621; C611; and P601-11/J105-11 to the left channel TREBLE CONTROL R107.

(11.5) The bass adjusted audio signal is fed from the variable tap of R105, through J105-9/P601-9 and R622 to the high-side of R625.

(11.6) The treble adjusted audio signal is fed from the variable tap of R107, through J105-12/P601-12 to the high-side of R625.

(11.7) The bass/treble adjusted audio signals are added at the high side of R625; and coupled through C613 to the base of the class A audio voltage amplifier Q605.

(11.7.1) There is some loss of audio signal through the bass and treble controls, and this loss is made up by Q605. The overall voltage gain Q602 through Q605 is approximately 13, with the bass

and treble ratios boosted or attenuated depending on the setting of R605 and R607 respectively.

(11.8) The amplified output of Q605 is coupled through C616 and then connected through P601-14/J105-14 (where it is connected to one side of MONO/STEREO SWITCH S113); and LEFT BALANCE CONTROL R104 to ground.

(11.8.1) The variable tap of R104 is connected to the high-side of the LEFT VOLUME CONTROL R101 to ground. The variable tap of R101 is connected through R114 to the input J102/4/P501-4 of the CHANNEL A AUDIO POWER AMPLIFIER MODULE.

(12) CHANNEL B: The entertainment program is fed to the input transistor Q607.

(12.1) By substituting Q607, Q608, Q609, and Q610 and their associated circuits for Q602, Q603, Q604, and Q605 and their associated circuits respectively, the operation of the right (B) channel preamplifier is the same as the left (A) channel as described above.

(12.2) RIGHT BASS CONTROL R106 and RIGHT TREBLE CONTROL R108 operation is the same as the left bass and treble controls.

(12.2.1) The individual left and right bass controls are adjusted in tandem by the BASS CONTROL KNOB being installed on the shafts of both controls, and the bass response of both channels is increased when the knob is moved up, and decreased when the knobs are moved down.

(12.2.1.1) When the controls are centered there is a boost of approximately 2 db in the bass response. This will help compensate for the loss in the human ear's response to low amplitude bass signals.

(12.3) The individual left and right treble controls are adjusted in tandem by the TREBLE CONTROL KNOB being installed on the shafts of both controls and the treble response of both channels is increased when the knob is moved up, and decreased when the knob is moved down.

(12.4) The left channel flat tape output signals are coupled from the output of Q609 through C620; and P602-26/J107-26 to the RIGHT CHANNEL TAPE OUTPUT JACK J115.

(12.5) The bass and treble adjusted amplified channel B audio is fed from the collector of Q610 through C628; and P602-18/J107-18 (where it is connected to one side of the MONO/STEREO SWITCH S113); and RIGHT BALANCE CONTROL to ground.

(12.5.1) The BALANCE potentiometer (R104 in channel A; and R103 in channel B) has a modified liner taper. When its slide contact is at 50% of its travel, the tap's resistance to ground is at 95% of the potentiometer's maximum resistance.

(12.5.2) Normally the controls are operated at their center position (50% travel). When BALANCE KNOB is moved to the left, R103 tap voltage decreases in a linear manner, but at the same time R104 tap voltage increases only about 5% giving

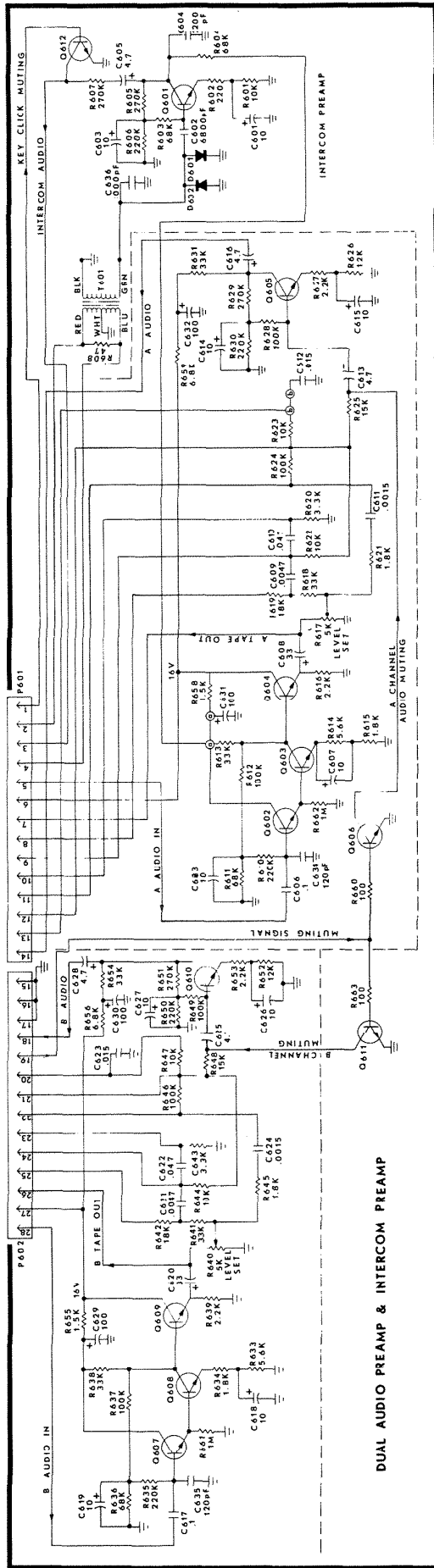

PREAMPLIFIER/INTERCOM PREAMP SCHEMATIC DIAGRAM

OPERATING VOLTAGES

PROGRAM SELECTOR SWITCH S111 in AUX POSITION (No Signal)
 Vcc at J105-6/P601-6 = 15.9Vdc
 Vcc at J107-27/F602-27 = 16.1Vdc

| DEVICE | FUNCTION | ELEMENT | | |
|--------|-----------------------|---------|------|-----------|
| | | EMITTER | BASE | COLLECTOR |
| Q601 | Channel A IC Preamp | 1.55 | 2.12 | 4.92 |
| Q602 | Channel A Input | 2.18 | 2.33 | 15.18 |
| Q603 | Channel A Amplifier | 1.59 | 2.18 | 6.30 |
| Q604 | Channel A Emit' Fol' | 6.01 | 6.30 | 15.9 |
| Q605 | Channel A Amplifier | 2.70 | 3.27 | 7.58 |
| Q606 | Channel A Mute Switch | 0 | 0 | 0(open) |
| Q607 | Channel B Input | 2.22 | 2.36 | 15.62 |
| Q608 | Channel B Amplifier | 1.62 | 2.22 | 6.89 |
| Q609 | Channel B Emit' Fol' | 6.27 | 6.39 | 16.1 |
| Q610 | Channel B Amplifier | 2.79 | 3.34 | 7.64 |
| Q611 | Channel B Mute Switch | 0 | 0 | 0(open) |
| Q612 | Key Click Mute Switch | 0 | 0 | 0(open) |

FIGURE 18

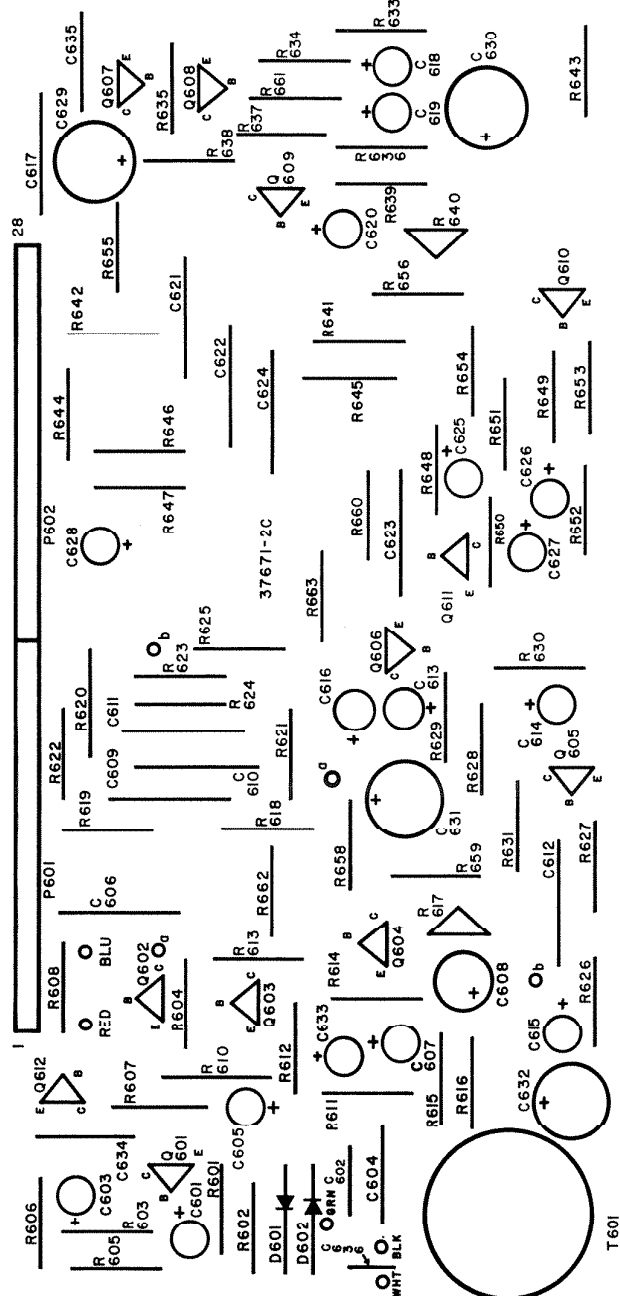

PREAMPLIFIER MODULE-TOP VIEW
COMPONENT LOCATION

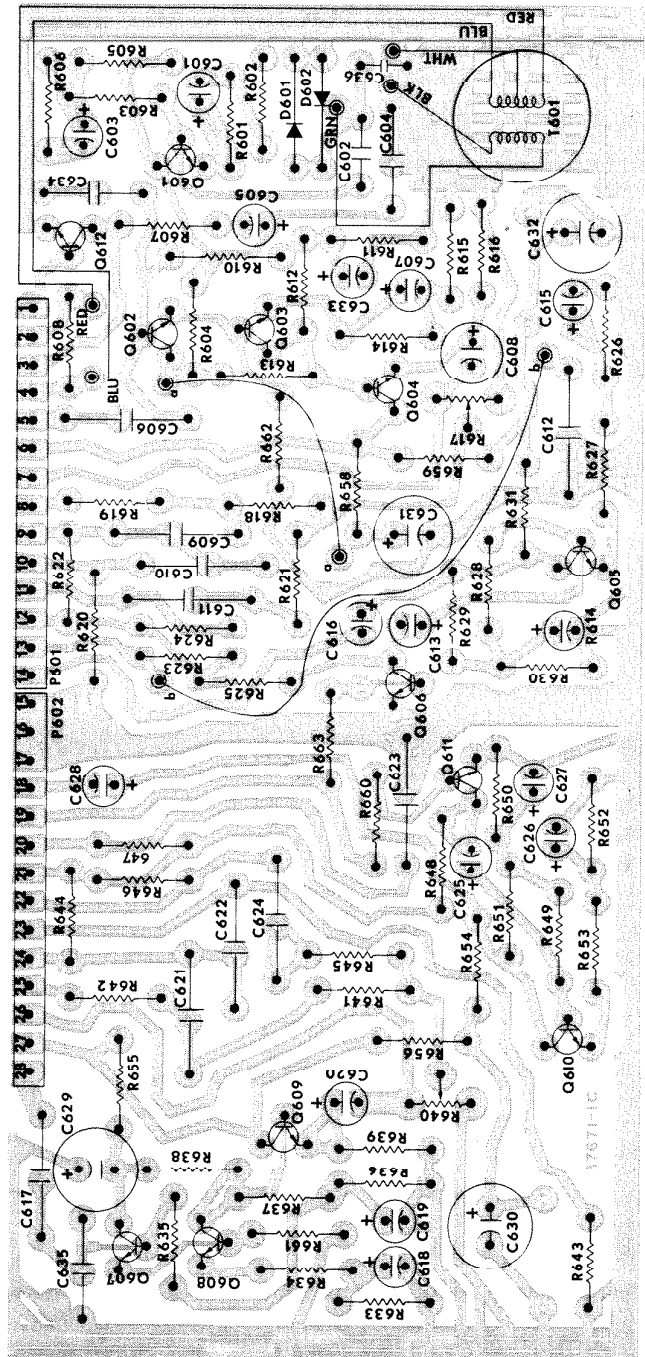

PREAMPLIFIER MODULE-BOTTOM VIEW
FOIL PATH/COMPONENT CONNECTION

FIGURE 19

an increase to channel A's volume of approximately 0.5 db. (Conversely when the knob is moved to the right, channel A's R104 decreases in a linear manner, and R103 tap voltage increases approximately 5% or 0.5 db.)

(12.6) The variable tap of R103 is connected to the high-side of the RIGHT VOLUME CONTROL R102 to ground. The variable tap of R102 is connected through R115 to the input J101-4/P501-4 of the CHANNEL B AUDIO POWER AMPLIFIER MODULE.

(17.7) The left and right volume controls are operated in tandem by the VOLUME KNOB being connected to the shafts of both R101 and R102. When the knob is raised the volume increases in both channels, and when lowered the volume decreases in both channels. When the knob is all the way down, both channels should be silent.

(18) STEREO/MONO SWITCH S113: The switch is shown in its normal stereo mode, when thrown to MONO, the output of the channel A preamplifier is added to the output of the channel B preamplifier and the same signal is fed to both power amplifiers. This results in the same (mono) signal being heard through both channel A and channel B speakers.

(19) VOLUME, BALANCE, BASS, AND TREBLE CONTROLS:

(19.1) Each of these controls is a 100 Kohm ($\pm 20\%$); 1/4 watt; carbon composition; slide-type variable resistor. They are identical in size and appearance.

(19.2) EACH OF THESE VARIABLE RESISTORS HAS A DIFFERENT TAPER, AND THEY ARE NOT INTERCHANGEABLE. USE THE EXACT NUTONE REPLACEMENT. ORDER BY PART NUMBER.

| | | |
|------------|-----------------|-----------|
| R101, R102 | Volume Control | 34660-000 |
| R103, R104 | Balance Control | 34661-000 |
| R105, R106 | Bass Control | 34662-000 |
| R107, R108 | Treble Control | 34663-000 |

(See Replacement Parts List, for complete description.)

(20) INTERCOM PREAMP

(20.1) The intercom signals, and when used, the signals from electronic chime and/or alarm systems, are fed to the MODULE through J105-2/P601-2 and J105-4/P601-4 to the center-tap balanced primary of the Intercom Input Transformer T601.

(20.2) The secondary output of T601 is coupled through C602 to the input of the intercom preamp Q601.

(20.2.1) The input is protected from High voltages (static, signals, etc.) by the back-to-back diodes D601 and D602.

(20.3) The output of Q601 is coupled through C605; R607; and P601-3/J105-3 to the input of the CHANNEL A AUDIO POWER AMPLIFIER at J102-4/P501-4.

(20.3.1) The output of Q601 at J102-4 is also connected through R114 and the combination of the VOLUME CONTROL R101, BALANCE CONTROL R104, C616, R631, and C632 to ground.

(20.4) The setting of the left channel Volume and Balance controls will effect the amplitude of the intercom signal that drives the base of Q501 in the channel A Audio Power Amplifier Circuit.

(20.5) In most properly operating systems, the BALANCE control will be set at approximately 50% (mid-range) of its total travel. (The control is at 95% of its total (100 Kohm) resistance) and in general the intercom amplitude is effected only by the setting of the VOLUME CONTROL R101.

(20.6) When VOLUME CONTROL R101 is in its mid-range (50% of travel) position, and the level of the intercom signal to the base of Q501 of the channel A audio power amplifier may be considered at 0 db level.

(20.6.1) If the VOLUME CONTROL R101's setting is increased to 90% of its total travel, the level of the intercom signal to base of Q501 will be increased by approximately 1.6 db.

(20.6.2) As the setting of R101 is increased above 90% of travel the input at Q501 will decrease, until at 100% of travel (i.e. all the way up) the intercom signal input to the base of Q501 will be 4.44 db below 0 db level of paragraph (20.6) above.

(20.6.3) If the setting of R101 is decreased from the 50% travel setting, the intercom input to base of Q501 will decrease, until the setting is at zero travel (i.e. all the way down) the level of the intercom input signal to Q501 will be 5.58 db below 0 db level of paragraph (20.6) above.

(20.6.4) The db levels given above are close approximations and the calculations were made while disregarding the reactance (X_c) of C616 and C632.

(20.7) The 10 Kohm resistor R114 is used so that the intercom signal will not be shorted out even though the VOLUME CONTROL R101 is set at zero.

(20.7.1) The 10 Kohm resistor R115 is used in channel B in order that the entertainment program to channel B's audio power amplifier will track with that of channel A's when the BALANCE and/or VOLUME controls are adjusted.

(21) MUTING:

(21.1) When one of the speaker stations are operated for intercom signals, there is a positive muting signal voltage generated at P103-12 that is fed through R125 to the base of Q101; through J105-19/P602-19, and then through R660 to the base of Q606 and through R663 to the base of Q611. (See CONTROL MODULE, THEORY OF OPERATION, below.)

(21.2) When the Model IS-47 Speaker/Clock Timer is in a silent mode a muting signal voltage is fed to ss and then through R122 to the base resistors of Q101; Q606 and Q611. (See SPEAKER/CLOCK TIMER, THEORY OF OPERATION, below.)

(21.3) The emitters of Q101; Q606 and Q611 are at ground. When their bases are forward biased by the muting signal voltage from the CONTROL MODULE and/or from the Speaker/Clock Timer, they will be saturated, and their collectors will go to ground.

(21.3.1) When Q101's collector is at ground, the audio signals at the junction of R115 and J101-4/P501-4 will be shorted out, and the audio output of channel B will be zero.

(21.3.2) When Q606 is saturated, its collector will ground the audio signals at the junction of R625 and C613, and Q605's entertainment program output will be zero.

(21.3.3) When Q611 is saturated, the junction of R648 and C625 is grounded and the output of Q610 is zero.

(21.3.3.1) Q611 is required when the MONO/STEREO MODE SWITCH is in MONO position. If not used, and the system is operating in an intercom mode, with S113 in MONO, the entertainment program of channel B would be fed through channel A's VOLUME and BALANCE controls to the input of the channel A audio power amplifier and would interfere with the signals being transmitted to the channel A speakers.

(21.4) When the muting signal is fed from the CONTROL MODULE and the activating intercom switch in the originating speaker is released, the muting transistors bias voltage will return to cutoff in something like 1/2 second, and the entertainment program will fade back in from zero to normal in approximately this time.

(22) KEY CLICK MUTING:

(22.1) When a "Talk" or "Listen" switch at a speaker is operated, a speaker/speakers is/are connected or disconnected across the primary of the Intercom Input transformer T601. This may introduce a voltage change in T601's primary which will be coupled through the transformer secondary to the base of Q601.

(22.2) Voltage changes on the base will be amplified by Q601 on the INTERCOM MODULE; and by Q501 and Z501 on the CHANNEL A AUDIO POWER AMPLIFIER MODULE. This noise will be heard as a "Key Click" through the speakers that are connected to the output of the channel A power amplifier.

(22.3) When the speaker's "Talk" or "Listen" switch is operated a voltage is generated on the CONTROL MODULE that is fed through J2B 12/P103-12; R109; and J105-1/P601-1 to the base of the "Key Click" muting transistor Q612.

(22.3.1) This positive "Key Click" muting signal voltage is generated for approximately 150 milliseconds, and is of sufficient amplitude to saturate Q612.

(22.3.2) This "Key Click" will be generated when a "Talk" or a "Listen" switch is pressed-in or when released.

(22.4) When Q612 is saturated, its collector is grounded and the audio signal at the output of Q601 is shorted out.

(22.5) This "Key Click" suppression may not completely silence the signal, but should reduce it so that it is not objectionable.

(23) SERVICING THE PREAMP MODULE:

(23.1) All operating voltages can be measured with the MODULE installed in the Parent Board. See voltage chart with Figure 18, page 24.

(23.2) When removing MODULE, pull straight out between card supports, disconnecting P601 from J105, and P602 from J106/J107, respectively.

(23.3) When installing MODULE, make certain that all pins of P601 and P602 are properly aligned with the jack connections of J105, J106, and J107.

(23.4) The PREAMP MODULE should normally be checked while installed in the Master Unit Parent Board, but it can be checked individually, as follows:

(23.4.1) Connect 16Vdc to P601-6 and P602-27, and the ground side (negative) of supply to P602-15.

(23.4.2) The operating voltages may be compared with those shown in chart. Figure 18.

(23.4.3) To check amplification, insert a calibrated 100 millivolt, 1 KHz. signal at left channel input P601-5 and measure flat amplified output at channel A Tape Output Pin P601-7—should be approximately 1300 millivolts.

(23.4.4) Check the channel A Audio Output at Pin P601-14. The voltage here will be less than that at P601-7 as the loss through the resistor capacitor coupling network without going through the base and treble controls will be greater than the amplification factor of Q605.

(23.4.5) If desired, the gain of Q605 can be checked by inserting the 1 KHz. signal at the junction of R625 and C613, and measuring the output at P601-14.

(23.4.5.1) Do not overdrive Q605, reduce input if necessary, as when wave starts to flatten out.

(23.4.6) To check channel B preamplifier, insert the 100 millivolt, 1 KHz. signal at P602-28, and measure gain of Q607-Q608-Q609 at channel B Tape Output Pin P602-26.

(23.4.7) Measure overall gain of channel B Output at Pin P602-18.

(23.4.7.1) To measure gain of Q610 insert signal at junction of R648 and C625, and measure output at P602-18. Do not over drive Q610.

(23.5) To check intercom preamp, insert audio signal between pins P601-2 and P601-4, and measure output at Pin P601-3. Output should approximate that of Q605 or Q610 when checked as shown in paragraphs (23.4.5) and (23.4.7.1) as applicable above.

POWER AMPLIFIER MODULE

(1) An individual POWER AMPLIFIER MODULE (NuTone Part No. 42014-000) is used in each channel.

(1.1) The system schematic diagram (back fold-out pages) shows both modules with their associated input circuits, output circuits, and speaker mode switches.

(2) Channel A Module's P501 is connected to J102 on the Master Unit Parent Board.

(3) Channel B Module's P501 is connected to J101 on the Master Unit Parent Board.

(4) The +17Vdc is filtered by C507 and fed to supply terminal Z501-1 of the power amplifier integrated circuit (IC).

(5) The +17Vdc is also fed through R508; filtered by C512, and then through R507 to the collector of Q501.

(6) The audio input is connected through P501-4 and C510 to the base of Q501.

(7) Q501 serves as an inverter with a gain of less than unity.

(8) The inverted signal is coupled from the collector of Q501 through C511 to the IC input Z501-8.

(8.1) The output of the IC at Z501-12 is in-phase with the input at Z501-8. By inverting the signal to the input, the output is out-of-phase with the input signal to the MODULE. This will help eliminate coupling (and possible oscillation) due to parallel input-output paths of the entertainment and intercom signals on the parent board and between speaker wiring and connections.

(9) The type TBA810AS (Z501, NuTone Part No. 36667-000) is supplied by SGS-ATES, and complete specifications and details are available in their CONSUMER TRANSISTORS & ICs DATA-BOOK, 1975/76.

(9.1) The IC includes amplifiers and inverters driving a linear class B power amplifier with low harmonic and crossover distortion.

(9.2) The IC is rated at a nominal 37 db voltage gain, but because of manufacturing variations the gain may vary between 34 and 40 db. With a 4 ohm load, the output may be 7 watts at 10% distortion. (At 5 watts the distortion will be less than 3%.)

(9.3) When operating with 16Vdc at input terminal Z501-1: A 1 KHz. signal input to Z501-8 of 80 mv. (226 mv p-p) and with 37 db gain the output should be 5.3 V (15V p-p).

(9.4) Differences in the gain of the IC's used in the A and B channels should be compensated for by adjusting the LEVEL SET CONTROL(s) in the preamplifier(s) sections. This will permit concurrent tracking of the volume and balance controls when adjustments are required.

(9.5) The quiescent output voltage at Z501-12 should equal $\frac{1}{2}$ the supply voltage to pin Z501-1.

(9.6) The IC includes on-board thermal protection for current limiting in case of short circuit to the output, and it is mounted on a heat-sink for greater heat dissipation.

(10) OUTPUT LOAD:

(10.1) The output load should not be less than 2.5 ohms.

(10.2) The NuTone SS-40 Deluxe 8-inch Speaker has a nominal impedance of 8 ohms. (See Figure 7, page 4.)

(10.3) Other speakers recommended for use with the SM-428 System have an impedance of 25 ohms. (See Figures 1 through 6, pages 3 and 4.)

(10.4) Ten of the latter speaker's combined impedance will be 2.5 ohms and may safely be connected to each channel.

(10.5) Three of the Model SS-40 Deluxe 8-inch Speakers may be connected to each channel. (As a rule, one deluxe 8-ohm speaker may be used in lieu of three, 25-ohm speakers.)

(11) GROUNDING

(11.1) To prevent audio ground loop currents, the amplifier output ground is isolated from the circuit common ground and earth ground.

(11.2) The audio input to base of Q501 is against circuit common ground.

(11.3) In a properly installed system, output ground; circuit common ground; and earth ground are connected together at the earth ground terminal — center left of the Parent Board (center right when viewed from rear of Master Unit).

(12) RIGHT SPEAKER(S) POWER AMPLIFIER:

(12.1) The channel B power amplifier drives the right speakers at a stereo speaker station.

(12.2) The channel B audio output is fed from P501-2/J101-2 to terminal R6 (terminal 6, rear section) of all SPEAKER MODE SWITCHES S101-S110.

(12.3) When a MODE SWITCH is in the RADIO/INTERCOM position, the audio signal is connected from R6 to common terminal R5; to the corresponding blue terminal on the TERMINAL BOARD and then through the blue wire to the blue terminal in the speaker control to which that MODE SWITCH is assigned.

(12.3.1) The other side of the speaker is connected through its blue/white terminal and wire and its blue/white terminal on the TERMINAL BOARD to output ground.

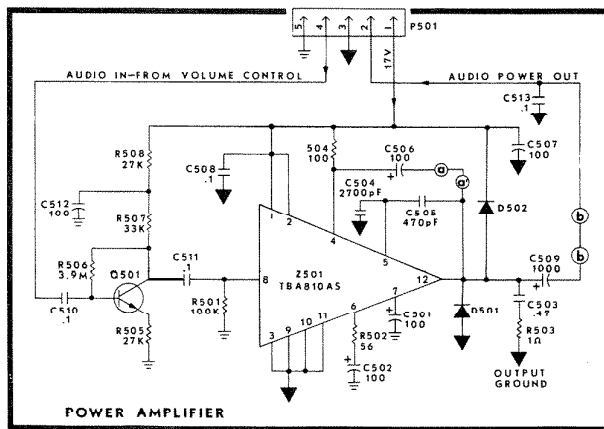

POWER AMPLIFIER SCHEMATIC DIAGRAM
OPERATING VOLTAGES

PROGRAM SELECTOR SWITCH S111 in AUX POSITION (No Signal)
Vcc at P501-1 = 16.2Vdc

| DEVICE | PIN NUMBER | | | | | | | |
|--------|------------|-----------|------|------|------|------|-----------|-----|
| | 1/2 | 3/9/10/11 | 4 | 5 | 6 | 7 | 8 | 12 |
| Z501 | 16.2 | 0 | 15.9 | 0.69 | 1.34 | 8.18 | 0.07 | 8.1 |
| | EMITTER | | | BASE | | | COLLECTOR | |
| Q501 | 4.26 | | | 4.39 | | | 6.68 | |

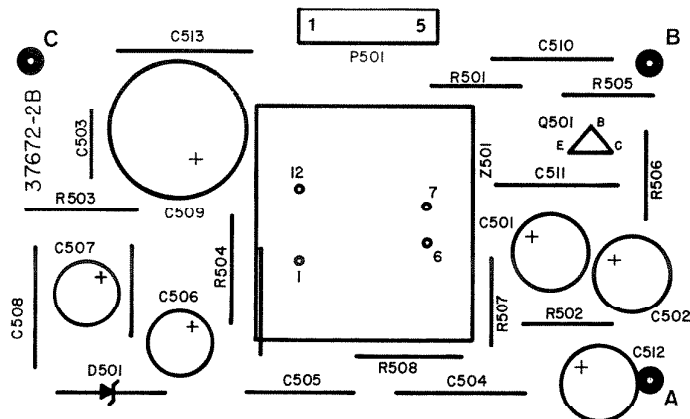

POWER AMPLIFIER MODULE-TOP VIEW-COMPONENT LOCATION

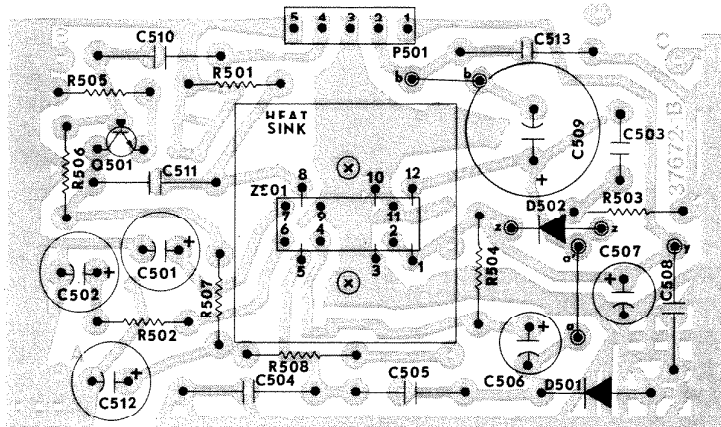

POWER AMPLIFIER MODULE-BOTTOM VIEW-FOIL PATH/COMPONENT CONNECTION

FIGURE 20

(12.3.1.1) NOTE: There are only 9 blue/white terminals on the TERMINAL BOARD. When 10 remote speaker controls are used, suggest that speakers No. 9 and No. 10's blue/white wire be connected to the same terminal.

(12.4) When a SPEAKER MODE SWITCH is in any other position, the output of the channel B power amplifier is open-ended at terminal R6 and the audio program will not be connected to the speaker controlled by that switch.

(12.5) Channel B audio input to the amplifier is muted when system is operating in any intercom mode. (See PRE-AMPLIFIER MODULE THEORY OF OPERATION, above.)

(13) LEFT SPEAKER(S) POWER AMPLIFIER:

(13.1) The channel A power amplifier drives the left speaker(s) at stereo station(s); and the speaker(s) at monaural station(s).

(13.1.1) Preamplified intercom signals from the PREAMP MODULE are also amplified through the channel A power amplifier.

(13.1.2) Entertainment program signals are muted when the system is operating in any intercom mode.

(13.2) Channel A's audio output is fed through P501-2/J102-2; A Audio PC path on Parent Board; P103-9/J2B-9; Talk/Listen Relay (K401-3-2-B to B (K401 in its normal de-energized position) on the CONTROL MODULE; J2A-1/P104-1 to terminal F8/9 (terminals 8 and 9, front section) of all SPEAKER MODE SWITCHES S101-S110.

(13.2.1) NOTE: Channel A's output is also connected, from the audio output PC path on the Parent Board, through the 330 ohm resistor R124 to output ground. This has little or no effect on the audio signal, but does supply a d-c ground path for the speaker control line when that speaker is operating in STANDBY (STBY), i.e. intercom only. (See intercom operation of speakers and CONTROL CIRCUIT MODULE, theory of operation below.)

(13.3) Channel A's output is against output ground. Output ground is connected through P103-10/J2B-10; T/L relay K401-1-2-A; J2A-2/P104-2: to terminal F2 of all SPEAKER MODE SWITCHES.

(13.4) When a SPEAKER MODE SWITCH is in RADIO/INTERCOM (RI) or STBY position, channel A's output is connected from F8 or F9, respectively, to F7; and then through the numbered red terminal on the TERMINAL BOARD and the red wire to the red terminal in the SPEAKER CONTROL.

(13.5) When the SPEAKER MODE SWITCH is in RI position, channel A's output ground is connected from F2 to F1 and then through the same numbered red/white terminal on the TERMINAL BOARD and the red/white wire to the red/white terminal in the SPEAKER CONTROL.

(13.5.1) When the SPEAKER MODE SWITCH is in STBY, the output ground is open-ended at F2; and with the CONTROL MODULE T/L relay K401 in its normal de-energized position, there is no ground return for the speaker, and it will not transduce the entertainment program audio signals. (Neither will it receive the chime nor alarm signals that may be connected to the SM-428 System.)

(13.5.1.1) The red/white return from the speaker is connected through the red/white wire and red/white terminal of the TERMINAL BOARD to terminal F1 of its controlling MODE SWITCH. When the switch is in STBY, terminal F1 is connected to STBY terminal F3 and then through the STBY line PC path on the Parent Board and P104-3/J2A-3 to the open STBY RELAY contact K402-2 — speaker ground still open.

(13.6) Further discussion of the SPEAKER MODE SWITCHES is included with the SPEAKER OPERATION below.

(14) SERVICING THE POWER AMPLIFIER MODULE:

(14.1) With the AMPLIFIER MODULE installed in the system, the operating voltages may be checked against the chart with Figure 20.

(14.2) To replace, pull MODULE straight out from Parent Board; and install new MODULE in PC card supports making certain that pins of P501 mate properly with jack connectors in Parent Board.

(14.3) BENCH SERVICING: When removed from the chassis, the POWER AMPLIFIER MODULE may be checked, as follows:

(14.3.1) Connect output ground terminal P501-3 to circuit common ground terminal P501-5.

(14.3.2) Connect a +16Vdc supply to P501-1 — connect ground (or negative) side to P501-5.

(14.3.3) If available connect a 4 ohm speaker between terminals P501-2 and P501-3. (A 4-ohm, 10-watt resistor may be used in lieu of speaker.)

(14.3.4) Connect a 1 KHz. signal, approximately 80 mv. to P501-4 — ground-side of signal generator to P501-5.

(14.3.5) With a db meter; AC volt meter; or oscilloscope measure signal at Z501-8. Should be slightly lower than input signal at P501-4. (Q501 is an inverter with a gain of less than unity.)

(14.3.6) Measure output voltage of power amplifier IC at P501-2 — should be approximately 37 db above input to Z501-8. This represents a gain of 70.

(14.3.6.1) Because of manufacturing tolerances in the IC's, output may vary between 34 and 40 db above input. This represents a gain between 50 and 100 times the input.

(14.4) When replacing the IC, use extreme care when removing the IC heat-sink. All solder must be removed, or softened when removing nuts

from mounting screws. Make certain that replacement IC tabs are secured between stand-offs and bottom of heat-sink.

(15) CIRCUIT CHANGES:

(15.1) Later production units (after April 11, 1977) differ from earlier units in the following manner: (See schematic diagram and PC layout, Figure 20.)

(15.1.1) In early production units D501 was an 18V Zener Diode. Later production units use a 1N4002, 100PIV, 1 amp diode.

(15.1.2) D502 (1N4002) was not used in earlier production units.

(15.1.3) Original production units incorporated a one microhenry choke between points b and b on the PC board. This choke is not used in later units.

(15.1.4) Earlier production units may be modified if desired. Later production boards are direct replacement.

CONTROL MODULE

(1) The module is supplied by +24Vdc through P103-14/J2B-14; and by +16Vdc through P103-15/J2B-15.

(2) The module is connected to circuit common ground through J2B-11/P103-11.

(3) The amplifier audio output ground is connected through P103-10/J2B-10 to terminals 6 and 1 of Talk/Listen (TL) relay K401.

(3.1) When K401 is not energized (as shown in schematic diagram, Figure 21), the output ground is connected through K401-A and J2A-2/P104-2 to terminal F2 of all SPEAKER MODE SWITCHES S101 through S110.

(4) Channel A audio power output is connected through P103-9/J2B-9 to terminals 8 and 3 of TL relay K401.

(4.1) When K401 is not energized (as shown in schematic diagram, Figure 21), the channel A audio output is connected through K401-B and J2A-1/P104-1 to terminals F8/F9 of the SPEAKER MODE SWITCHES S101 through S110.

(5) The orange input wires are connected from the orange terminals in the speaker controls through the two common orange terminals on the TERMINAL BOARD; J803-4/P102-4; the orange PC path on the Parent Board; P104-6/J2A-6; to TL relay K401-D.

(5.1) When K401 is not energized, the orange input is connected from K401-7 through J2A-8/P104-8; Intercom Signal path on Parent Board; and J105-4/P601-4 to one side of the Intercom Input Transformer on the DUAL AUDIO PREAMP & INTERCOM PREAMP MODULE.

(6) The orange/white input wires are connected from the orange/white terminals in the speaker controls through the two common orange/white terminals on the TERMINAL BOARD; J802-11/P105-11; the orange/white PC path on the Parent Board; and P104-5/J2A-5 to TL relay K401-C.

(6.1) When K401 is not energized, the orange/white input is connected from K401-5 through J2A-7/P104-7; Intercom Signal Path on the Parent

Board; and J105-2/P601-2 to the other side of the Intercom Input Transformer T601.

(7) The Standby (STBY) line (used by speakers that are operating in STBY (Intercom Only) mode) is connected from the STBY terminal F3 of all SPEAKER MODE SWITCHES through P-104-3/J2A-3 to one side of the switch of STBY relay K402-2.

(7.1) The other side of relay switch K402-1 is connected to the red/white (normal audio output ground to the SPEAKER MODE SWITCHES).

(8) The black wires from all speaker controls are connected in common at the two black terminals on the TERMINAL BOARD; and then through J801-24/P106-24 and R119 to the Control Line PC path on the Parent Board.

(8.1) The black/white wires from all speaker controls are connected in common at the two black/white terminals on the TERMINAL BOARD; and then through J801-3/P106-3 and R118 to the Control PC path on the Parent Board.

(8.2) The Control Line is connected through P104-4/J2A-4 to D407 and D401.

(9) NOTE: The Door Speaker(s) should be connected — through the two wires of a 22 ga. twisted-pair cable(s) (NuTone IW-2) — to the black and black/white terminals on the TERMINAL BOARD or, if more convenient, to the black and black/white terminals in the nearest speaker control(s).

(10) When a speaker's I/P TALK; DOOR TALK; or DOOR LISTEN switch is activated (pressed-in) the control line is connected to ground through a low resistance.

(10.1) This resistance may vary between 25 and 200 ohms depending on which switch is activated and the operating mode of the speaker as controlled by its SPEAKER MODE SWITCH (S101-S110).

(10.2) When the Control Line is connected to ground through the low resistance, the voltage at Point X goes to approximately .86 volts (drop across D407 plus drop through Control Line resis-

larice), and the base of PNP control transistor Q401 is forward biased and the transistor is turned ON.

(11) When Q401 is turned ON, the collector (Point Z) goes to approximately 14.6 volts.

(12) When Point Z goes to 14.6 volts, Veb of the PNP "Key Click" muting control transistor Q404 is positive by the drop across D405 (from voltage chart, Figure 21, this voltage is 0.6 volts) and the transistor is clamped OFF.

(13) The positive 14V at the emitter of Q404 is divided between R414 and R415 to ground, and the potential at the high (+) side of C403 is approximately 9.5 volts.

(13.1) This 9.5V is pulsed through C403 and D406 to Point W. The voltage decays at a rate that is determined by the RC time constant of C403 and the resistance of R416 in parallel with R417 and D406.

(13.2) This positive voltage at Point W is the "Intercom Key Click Muting Signal" and its duration is 150-200 milliseconds.

(13.3) This signal is connected through J2B-12/P103-12; R109; and J105-1/P601-1 to the base of the key click muting transistor Q612 on the PRE-AMPLIFIER MODULE. (See paragraphs (22) through (22.5) under DUAL AUDIO PREAMP & INTERCOM PREAMP MODULE, THEORY OF OPERATION above.)

(14) When a speaker's I/P LISTEN switch is activated (pressed-in) the control line is connected to ground through a 10 Kohm resistor; Point X goes to 10.3 volts; and Point Y goes to 10.5 volts.

(14.1) The Intercom Key Click Muting Signal is generated in the same manner as described in paragraphs (10.2) through (13.3) above.

(15) When the speaker's TALK or LISTEN switch is released, Point X returns to 16 volts; Q401 is turned OFF; and Points Y and Z return to zero volts.

(16) When Point Z returns to zero, Q404 is forward biased as a result of the 9.5 volt charge on C403, and the capacitor discharges through the transistor.

(17) When C403 discharges through W, the Key Click Muting Voltage at high side of R417 goes to approximately 4 volts and decays at a rate as determined by C403 and the combination of the resistors R414, R415, R416, and R417. This time constant is longer than the time constant for C403 charging (see paragraph (13.1) above), but since the Key Click Muting Voltage at R417 starts at a lower level than when C403 is charging, its duration is only slightly longer.

(18) The 9.5 volts at Point W when TALK or LISTEN switch is pressed-in and the 4 volts at Point W when the TALK or LISTEN switch is released can be observed on an oscilloscope.

(18.1) The momentary voltage at Point W can be measured with a VTVM or digital readout meter

(and in some cases by a 20 Kohm per volt multi-meter). Since these meters average the pulse, the meter will read between 0.3 and 0.7 volts at make and at break. The meter reading will decay to zero very quickly.

(19) When Point Z goes high to 14.6 volts, the base of the NPN STBY switching transistor Q403 is forward biased and the transistor is turned ON.

(19.1) When Q403 is turned ON, STBY relay K402 is energized and the STBY line is connected to the red/white (channel A audio output ground) line from the SPEAKER OPERATING MODE SWITCHES. (This affects only the speakers that are operating in the STBY (Intercom Only) mode.

(20) When a speaker's TALK or LISTEN switch is held-in, the 14.6 volts at Point Z is divided by R410; R411; D402; and R412; and the Audio Muting Signal at Point U (high (+) side of C402) is approximately 3 volts.

(20.1) The voltage is connected through J2B-13/P103-13 to the Audio Muting Signal PC Path on the Parent Board.

(20.2) From the PC Path the voltage is connected through R125 to the base of muting transistor Q101; and through J107-14/P602-14; and R660 and R663 to the base of muting transistors Q606 and Q611 respectively. (See paragraphs (21) through (21.4) under DUAL AUDIO PREAMP MODULE THEORY OF OPERATION, above.)

(21) When the speaker's TALK or LISTEN switch is released, Point Z goes to zero, and the 3 volts at Point U starts to decay in an RC manner as determined by C402 and R412.

(21.1) The forward bias to Q101; Q606 and Q611 will decrease from saturation through cutoff to zero. The entertainment program will fade-in to full volume in approximately 1/2 second.

(22) When a speaker's I/P TALK, DOOR TALK, or DOOR LISTEN switch is held-in, the potential at Point Y is approximately 1.48 volts. This potential is connected through divider R404, R405, and R406 so that the bias on the base of Q402 is 0.26 volts. Since this is not sufficient to turn T/L switching transistor Q402 ON, it will remain OFF and TL relay K401 will be de-energized.

(23) When a speaker's I/P LISTEN switch is activated, the potential at Point Y rises to a value approaching 10.5 volts. This potential is connected through R404 and R405 and divided by R406 so that a forward bias of 1.28 volts is applied to Q402. Q402 is turned ON and the T/L relay K401 is energized.

(24) When T/L relay K401 is energized, the red speaker path from terminals F8 (RI) and F9 (STBY) of the SPEAKER OPERATING MODE SWITCHES S101-S110 is connected through K401-B/4; J2A-8/P104-8; one Intercom Signal Path on the Parent Board; and J105-4/P601-4 to one side of the Intercom Input Transformer T601 on the PREAMP MODULE.

(24.1) When T/L relay K401 is energized, the red/white speaker path from terminal F2 (RI) of

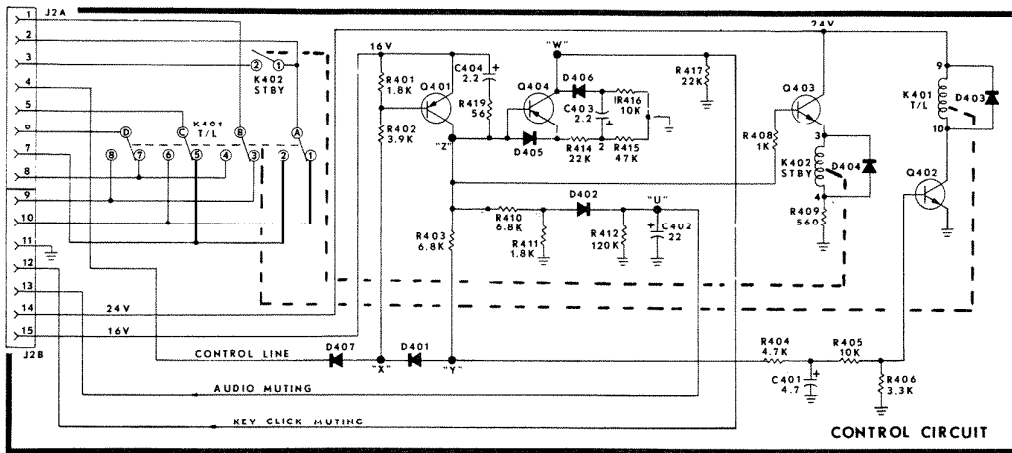

CONTROL CIRCUIT OPERATING VOLTAGES

Vcc at P103-14/J2B-14= +24.4Vdc (+19.3 Vdc when PROGRAM SELECTOR SWITCH S111 is in FM position).
 Vcc at P103-15/J2B-15= +16Vdc.

Measure Point "W" (and collector of Q404) "Key Click" muting voltage at J2B-12/P103-12.

Measure Point "U" muting voltage at J2B-13/P103-13. Should read approximately +3V when any speaker control "Talk" or "Listen" switch is pressed-in. Voltage will decay to zero in approximately 1/2 second when switch is released.

VOLUME CONTROL R101 & R102 set to normal operating position.

PROGRAM SELECTOR SWITCH S111 in AUX position. (Voltages are approximately the same if switch is in PHONO, TAPE, or AM position.)

Music Prgm. operating mode; indicates entertainment program, i.e. no speaker "Talk" or "Listen" switch is activated.

| OPERATING MODE | Q401 | | | Q402 | | | Q403** | | | Q404 | | | CONTROL LINE PTS | |
|----------------|------|------|------|------|------|------|--------|------|------|------|------|------|------------------|------|
| | E | B | C(Z) | E | B | C | E | B | C | E | B | C(W) | X | Y |
| Music Prgm. | 16 | 16 | 0 | 0 | 0 | 0 | 0 | 0 | 24.4 | 0 | 0 | 0 | 16 | 0 |
| I/P Talk | 15 | 13.7 | 14.6 | 0 | 0.26 | 23.2 | 13.8 | 14.6 | 23.2 | 14 | 14.6 | .7-0 | 0.86 | 1.48 |
| I/P Listen | 15 | 13.7 | 14.6 | 0 | 1.28 | 0.9* | 13.8 | 14.6 | 18.2 | 14 | 14.6 | .7-0 | 10.3 | 10.5 |
| Door Talk | 15 | 13.7 | 14.6 | 0 | 0.26 | 23.2 | 13.8 | 14.6 | 23.2 | 14 | 14.6 | .7-0 | 0.86 | 1.48 |
| Door Listen | 15 | 13.7 | 14.6 | 0 | 0.26 | 23.2 | 13.8 | 14.6 | 23.2 | 14 | 14.6 | .7-0 | 0.86 | 1.48 |

NOTE: (*) When any speaker "I/P Listen" switch is pressed-in, Q402 is turned ON, and T/L Relay K401 is energized.

(**) STBY Relay K402 is energized when any speaker's "Talk" or "Listen" switch is pressed-in. (Q403 turned ON).

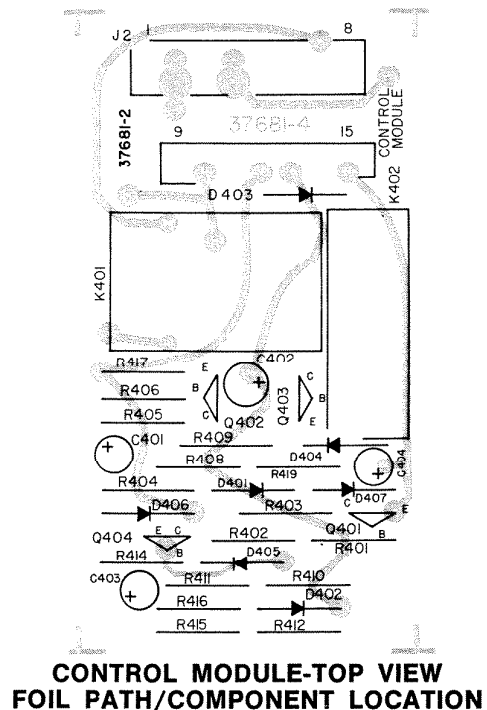
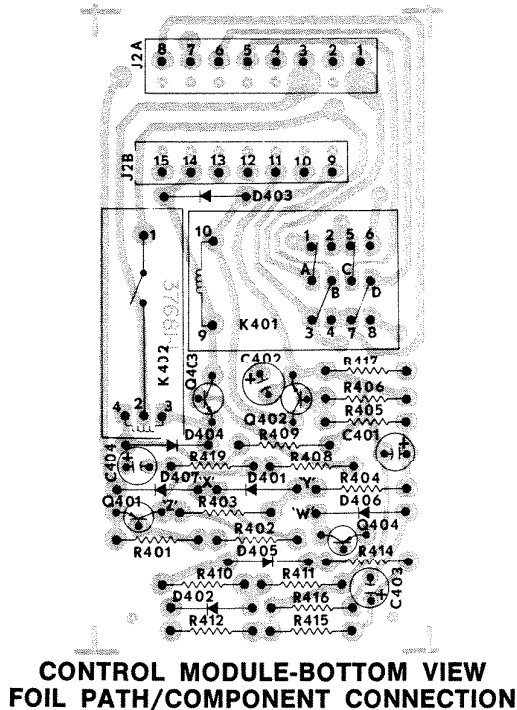

FIGURE 21

The MODE SWITCHES K101-K110 is connected through K401-A/2 J2A-7/P104-7; the other Intercom Signal Path on the Parent Board; and J105-2/P601-2 to the other side of T601.

(24.2) All speakers, other than the initiating speaker, that are in RI or STBY mode will act as "Hands free" transmitting transducers (microphones) and sounds in their vicinity will be heard by the initiating speaker.

(24.2.1) NOTE: Speaker(s) other than the initiating speaker that are in STBY mode will be connected to the red/white path via the STBY F3 terminal of its MODE SWITCH; STBY path on Parent Board; P104-3/J2A-3 and STBY relay terminals K402-2/1 to the red/white speaker path on the CONTROL MODULE. (K402 is energized during all intercom operations, see paragraphs (19) and (19.1) above.)

(25) When a speaker control's I/P LISTEN switch is held-in, its speaker (channel A speaker at stereo station) is connected across the orange and orange/white leads. (T/L relay K401 is energized).

(25.1) The orange speaker path is connected through K401-D/8 to the channel A red audio lead; and the orange/white path is connected through K401-C/6 to the channel A red/white audio lead. Signals transmitted by the other speakers that are in RI or STBY mode (paragraph (24.2) above) are heard at the speaker with its I/P LISTEN SWITCH activated.

(26) SERVICING THE CONTROL MODULE:

(26.1) The operating voltages should be checked with the CONTROL MODULE installed in the Parent Board; compare with voltage chart shown with figure 21.

(26.2) Operation of the CONTROL MODULE can be simulated by shorting black terminal on TERMINAL BOARD to ground.

(26.2.1) To simulate I/P LISTEN operation, connect a 10 Kohm resistor between black terminal and ground.

(26.3) To remove MODULE, pull straight out away from Parent Board — disconnecting J2A from P104 and J2B from P103.

(26.4) When replacing MODULE, make certain that pins of P103 and P104 properly engage the connections of J2B and J2A respectively.

(26.4.1) Pins 1, 2, 9, and 10 must be engaged so that channel A's audio output can be connected to the speakers.

(26.5) If MODULE is removed from the chassis, short pins: P103-9 to P104-1; and P103-10 to P104-2 so that channel A speakers will receive output.

(26.6) BENCH SERVICING:

(26.6.1) For convenience the MODULE should be checked while installed in an SM-428 Master Unit.

(26.7) If a chassis is not available, the MODULE operation may be simulated in the following manner:

(26.7.1) Connect a 19 to 24 Vdc supply to J2B-14; and a 16 Vdc supply to J2B-15; connect ground (negative) side of supply to J2B-11.

(26.7.2) Should have continuity between J2B-9 and J2A-1; between J2B-10 and J2B-2; between J2A-5 and J2A-7; and between J2A-6 and J2A-8.

(26.7.3) To simulate action of I/P TALK; DOOR TALK; and DOOR LISTEN operation: short Control terminal J2A-4 to ground terminal J2B-11; compare operating voltages with those shown in Figure 21.

(26.7.3.1) Check for STBY continuity (K402-2 to K402-1) between J2A-3 and J2A-2.

(26.7.4) To simulate action of I/P LISTEN operation: connect a 10 Kohm resistor between control terminal K2A-3 and ground terminal K2B-11; compare operating voltages with those shown in Figure 21.

(26.7.4.1) Check for STBY continuity (K402-2 to K401-1) between J2A-3 and J2A-2.

(26.7.4.2) Check T/L relay K401 operation: With relay energized: should have continuity between J2B-9 and J2A-6; between J2B-10 and J2B-5; between J2A-8 and J2A-1; and between J2A-7 and J2A-2.

MASTER UNIT TERMINAL BOARD / REMOTE COMPONENTS WIRING

(See SYSTEM SCHEMATIC DIAGRAM, Figure 24)

(1) THE RECOMMENDED WIRE AND CABLE MUST BE USED BETWEEN THE TERMINAL BOARD IN THE SM-428 MASTER UNIT AND THE REMOTE COMPONENTS

(2) OBSERVE COLOR CODE.

(3) NuTone IW-8, four twisted-pair, color-coded cable should be used between the TERMINAL BOARD and the stereo speaker controls.

(4) NuTone IW-6, three twisted-pair, color-coded cable can be used between the TERMINAL BOARD and the monaural speaker controls.

(4.1) IW-8 may be used in lieu of IW-6 between the TERMINAL BOARD and the monaural speaker controls. When so used, the blue and blue/white wires must be insulated and tied back so that they can not short at the TERMINAL BOARD nor at the speaker control.

(5) NuTone IW-2, 22 ga. twisted-pair cable should be used between individual speaker control and its associated remote speaker(s).

(6) IW-2 should be used between door speaker(s) and the black and black/white terminals on the TERMINAL BOARD (Or, if more convenient, door speaker(s) may be connected to the black and black/white terminals in any speaker control).

(7) The signals from a NuTone electronic chime and/or the signals from a NuTone alarm horn may be connected to the Master Unit so as to be heard by the I/P speakers that are operating in the Radio Intercom Mode. (The I/P speaker's operating mode is determined by the setting of its individual SPEAKER OPERATING MODE SWITCH S101-S110.)

(7.1) In compliance with the instructions that are furnished with the chimes and alarm systems, connect the IW-2 between the pickup in the electronic chime and/or the pickup in the alarm horn and the CHIME terminals on the Master Unit TERMINAL BOARD.

(7.2) When chime and/or alarm signals are transmitted through the system, the entertainment program is not muted, and these signals must override the entertainment program. (See paragraph (8), page 7 through (8.4), page 9.)

(8) IS-47 SPEAKER/CLOCK TIMER:

(8.1) The IS-47 is operated monaurally (channel A only) and its speaker controls are identical to the

monaural controls shown with No. 3 speaker in the SCHEMATIC DIAGRAM, Figure 24.

(8.2) The IS-47 should be installed in the Model IR-7 Rough-in Housing.

(8.2.1) The Class A 120Vac, 60 Hz. line must be installed in the rough-in housing in order to power the clock — observe local code. The housing should be grounded to 120V power line earth ground.

(8.3) The IS-47 PROTECTION CIRCUIT is installed in the Master Unit:

(8.3.1) Mount the P31 and Wire Assembly at Parent Board mounting screw in Master Unit Chassis. (Figure 9, page 8)

(8.3.2) Connect the red wire from P31 to the red wire from (SS) on the Parent Board. Use solderless connector.

(8.3.3) Connect the yellow wire from P31 to the yellow wire from (rr) on the parent board. Use solderless connector.

(8.3.4) Connect the black wire from P31 to a ground terminal — Parent Board mounting screw.

(8.3.5) Connect control line IW-2 between the violet wires of the Protection Circuit and TB21 of the Clock Timer Controls in the IS-47.

(8.3.6) The Protection Circuit's J31 should be connected to P31.

INTERCOM OPERATION

(See SYSTEM SCHEMATIC DIAGRAM, Figure 24)

(1) The intercom circuit operation is the same for stereo and monaural speaker controls. (Figure 24)

(2) The audio circuits at the speaker controls differ as follows:

(2.1) The stereo speaker control includes, blue and blue/white terminals; channel B speaker volume control R1B; and terminals for connecting the IW-2 wiring to channel B speaker, which are not included in the monaural controls.

(2.2) The stereo control's channel A and channel B volume controls R1A and R1B are mounted concentrically. Turn the outer knob (ring) to adjust R1A — the channel A volume. Turn the inner knob to adjust R1B — the channel B volume.

(2.3) The monaural control incorporates R1 for adjusting its speaker's volume (channel A).

(2.4) Turn controls clockwise to increase volume, and counter clockwise to decrease volume.

(3) R1A (channel A) in the stereo control, and R1 (channel A) in the monaural control also determine the level of the audio signal that is sent from the speaker when it is used as a microphone for transmitting intercom signals.

(4) ALL I/P SPEAKERS IN RADIO/INTERCOM (RI) MODE: SPEAKER NO. 1 ORIGINATES TALK TO DOOR SPEAKER(S):

(4.1) ACTIVATE DOOR TALK SWITCH S2A/S2B.

(4.2) One side of door speaker(s) will be connected through the black terminal; S1-2/1; and S2A-2/3 to the red/white terminal. Other side of door speaker(s) will be connected through the black/white terminal; S1-5/4; and S2B-2/3 to the red terminal.

(4.3) The red and red/white wires from the speaker control are connected to the No. 1 red and red/white terminals on the Master Unit TERMINAL BOARD.

(4.3.1) The No. 1 red/white terminal is connected through J803-3/P102-3; S101F-1/2; P104-2/J2A-2; K401-A/1; and J2B-10/P104-10 to output ground.

(4.3.2) The No. 1 red terminal is connected through J803-2/P102-2; S101F-7/8/9; P104-1/J2A-1; K401-B/3; and J2B-9/P103-9 to channel A audio output.

(4.4) The channel A speaker common side will be connected through S2A-5/6 to the orange terminal.

(4.4.1) The other side of channel A speaker will be connected through part of R1A (depending on setting); and S2B-5/6 to the orange terminal.

(4.5) The orange and orange/white wires from the speaker are connected to the orange and orange/white terminals on the Master Unit TERMINAL BOARD.

(4.5.1) The orange terminal is connected through J803-4/P102-4; P104-6/J2A-6; K401-D/7; J2A-8/P104-8; one side of the Intercom Signal Line; and J105-4/P601-4 to one side of the intercom input transformer T601 on the DUAL AUDIO PREAMP & INTERCOM PREAMP MODULE.

(4.5.2) The orange/white terminal is connected through J102-11/P105-11; P104-5/J2A-5; K401-C/5; J2A-7/P104-7; the other side of the Intercom Signal Line; and J105-2/P601-2 to the other side of T601 on the PREAMP MODULE.

(4.6) The CONTROL LINE will be connected from point X on the CONTROL CIRCUIT MODULE, through D407; J2A-4/P104-4; R119; P100-24/J801-24; black terminal on TERMINAL BOARD; and black wire to black terminal in No. 1 speaker control.

(4.6.1) With the DOOR TALK SWITCH S2A/S2B activated, the Control Line is connected from the No. 1 speaker control's black terminal through S1-2/1; S2A-2/3; red/white speaker terminal/ and then through the red/white path to output ground as shown in paragraphs (4.3) and (4.3.1) above. The output ground is connected to circuit common ground on the Master Unit Parent Board.

(4.6.2) When the CONTROL LINE is taken to ground (or, as in this case, approximately 43 ohms above ground), the key-clicks are muted, and channels A and B entertainment programs are muted. See CONTROL MODULE, THEORY OF OPERATION, paragraphs (10) through (13.3); and (20) through (20.2) above.

(4.7) The audio signals from the No. 1, channel A, speaker will be heard through the door speaker(s) and through I/P speakers that are in RI or STBY mode. (See CONTROL MODULE, THEORY OF OPERATION, paragraphs (19) and (19.1) above.)

(4.8) When speaker control No. 1's DOOR TALK SWITCH S2A/S2B is released, the door speaker(s) will be disconnected from the channel A amplifier output and its channel A speaker will be reconnected across the red and red/white pair (channel A output).

(4.8.1) The CONTROL line will be opened; key-click muting will be activated, entertainment muting signal will be turned off; and the entertainment program will resume in channel A and B. (See CONTROL MODULE, THEORY OF OPERATION, paragraphs (15) through (18.1); (21) and (21.1) above.)

(5) ALL I/P SPEAKERS IN RI MODE: SPEAKER NO. 1 ORIGINATES LISTEN TO DOOR SPEAKER(S):

(5.1) ACTIVATE DOOR LISTEN SWITCH S1.

(5.2) One side of door speaker(s) is connected from black terminal through S1-2/3 to orange terminal; and other side of door speaker(s) is connected through S1-5/6 to the orange/white terminals.

(5.3) The orange and orange/white terminals are connected to the intercom input transformer T601 on the PREAMP MODULE through the paths shown in paragraphs (4.5) through (4.5.2) above.

(5.4) The Control Line is connected from point X on the CONTROL CIRCUIT MODULE to the black and black/white terminals on the No. 1 speaker control.

(5.4.1) From the black terminal it is connected through S1-2/3; and the orange terminal back through the orange circuit to one side of T601's primary through its center-tap to ground.

(5.4.2) From the black/white terminal, it is connected through S1-5/6 and the orange/white terminal back through the orange/white circuit to the other side of T601 and through its center tap to ground.

(5.4.3) The Control line will be taken to approximately 24 ohms above ground: the key-clicks will be muted; and channels A and B entertainment programs will be muted. See CONTROL MODULE, THEORY OF OPERATION, paragraphs (10) through (13.3); and (20) through (20.2) above.

(5.5) The intercom signals from the door speaker(s) will be heard through all I/P speakers that are in RI or STDY mode.

(5.6) When the DOOR LISTEN SWITCH S1 is released, the door speaker(s) will be disconnected from the channel A intercom preamp input; the Control Line will be opened, key-click muting will be activated; entertainment program will fade-back in both channel A and B speakers. (See CONTROL MODULE, THEORY OF OPERATION, paragraphs (15) through (18.1); and (21) and (21.1) above.)

(6) ALL I/P SPEAKERS IN RI MODE: SPEAKER NO. 1 ORIGINATES TALK TO I/P SPEAKERS:

(6.1) ACTIVATE I/P TALK SWITCH S4A/S4B.

(6.2) One side of channel A speaker is connected through S2A-5/4; S3A-2/1; and S4A-5/6 to the orange terminal; and the other side of channel A speaker is connected through part of R1A (depending on setting); S2B-5/4; S3B-5/4; and S4B-2/3 to the orange/white terminal.

(6.3) The orange and orange/white terminals are connected to the intercom input transformer T601 on the PREAMP MODULE through the paths shown in paragraphs (4.5) through (4.5.2) above.

(6.4) The CONTROL LINE is connected from Point X on the CONTROL CIRCUIT MODULE, through the black terminal on the speaker No. 1 control; and S4B-5/6 to the red/white terminal.

(6.4.1) From the red/white terminal, the CONTROL LINE will be connected to circuit ground as shown in paragraph (4.3.1) above.

(6.5) When the CONTROL LINE is taken to ground (or, as in this case, to approximately 43 ohms above ground), the key-click and entertainment program muting takes place as described in paragraph (4.6.2) above.

(6.6) The audio signals from the No. 1 channel A speaker will be heard by all other I/P speakers that are in RI or STBY mode.

(6.7) When the I/P TALK switch S4A/S4B is released, the No. 1 channel A speaker will be connected across the channel A amplifier output, the key-click muting will be activated and the entertainment muting will be turned off; and the entertainment program will resume (fade back to both channel A and channel B speakers). (See CONTROL MODULE, THEORY OF OPERATION, paragraphs (15) through (18.1); (21) and (21.1) above.)

(7) ALL I/P SPEAKERS IN RI MODE: SPEAKER NO. 1 ORIGINATES LISTEN TO OTHER I/P SPEAKERS:

(7.1) ACTIVATE I/P LISTEN SWITCH S3A/S3B.

(7.2) The CONTROL LINE is connected from Point X on the CONTROL CIRCUIT MODULE, through R119 to the black terminal on the speaker control.

(7.2.1) From the black terminal, it is connected through S4B-5/4; 10 Kohm resistor R2; and S3A-5/6 to the orange terminal.

(7.2.2) From the orange terminal on the No. 1 speaker control, the CONTROL LINE is connected through the orange path and one side of the intercom input transformer T601 to center-tap ground.

(7.3) When the CONTROL LINE is connected through R2 to ground, the TALK/LISTEN relay K401 on the CONTROL CIRCUIT MODULE is energized. (See paragraphs (23) through (25.1) under CONTROL MODULE, THEORY OF OPERATION, above.)

(7.4) When T/L relay K401 is energized the orange lead (and thus the CONTROL LINE) is switched from K401-D/7 to K401-D/8; and from there through J2B-9/P103-9; the channel A audio output path on Parent Board; and R124 to ground. (R124 being 330 ohms, has very little loading effect of the channel A audio signal.) This maintains the high resistance in the CONTROL LINE and keeps K401 energized.

(7.5) Even though the No. 1 channel A speaker is connected to the orange and orange/white leads at its control, it is connected across the channel A audio output. (See CONTROL MODULE reference of para (7.3) above.)

(7.5.1) All other I/P speakers that are in RI or STBY mode will be connected through their red and red/white leads (STBY lead for speakers in STBY) to the intercom input transformer T601.

(7.5.2) Signals in the vicinity of the other I/P speakers will be heard (Hands-Free) by the No. 1 speaker.

(7.6) When the I/P LISTEN switch S3A/S3B is activated, the key-click muting and entertainment

program muting are as described in paragraphs (14) and (14.1); and (20) through (20.2) under CONTROL MODULE, THEORY OF OPERATION, above.

(7.7) When I/P LISTEN switch is released, the key-clicks are muted, the originating speaker and the other I/P speakers are returned to their normal condition across the channel A output; entertainment muting is turned off; and the program fades back to the speakers as described in paragraphs (15) through (18.5); and (21.1) under CONTROL MODULE, THEORY OF OPERATION, above.

(8) SPEAKER NO. 1 IN STANDBY (INTERCOM ONLY) MODE:

(8.1) THROW SPEAKER OPERATING MODE SWITCH S101 TO STANDBY (STBY) POSITION:

(8.1.1) The channel B audio output path (blue) is open-ended at S101R-6 and speaker No. 1's B channel speaker is OFF.

(8.1.1.1) NOTE: The channel B speaker is ON only when its respective OPERATING MODE SWITCH is in RADIO/INTERCOM (RI) position.

(8.1.2) The channel A audio output path is completed through S101F-9/8/7 to speaker No. 1's A channel speaker.

(8.1.2.1) The No. 1 channel A speaker's ground return path is connected through S101F-1 and the STBY terminal S101F-3 to the STBY path on the Parent Board.

(8.1.2.2) When no intercom function is being used, the STBY line is open-ended at STBY relay contact K402-2 on the CONTROL MODULE.

(8.1.2.3) With this open ground return the channel A speaker is OFF to entertainment program signals, and to chime and/or alarm signals that may be fed to the system.

(8.2) When any DOOR TALK; DOOR LISTEN: I/P TALK; or I/P LISTEN switch at any I/P speaker control is activated, the STBY line at K402-2 is connected to the output ground line at K402-1 and the speaker in STBY will have complete intercom operation with door and I/P speaker(s). (See paragraphs (19); (19.1); and (24.2.1) under CONTROL MODULE, THEORY OF OPERATION, above.)

(9) SPEAKER NO. 1 IN LISTEN-IN (LI) MODE:

(9.1) THROW SPEAKER OPERATING MODE SWITCH S101 TO LISTEN-IN (LI) POSITION.

(9.1.1) The No. 1 channel B speaker is turned OFF by S101R.

(9.1.2) The channel A audio output line is open-ended at S101F-9/8, and the channel A output ground is open-ended at S101F-2 and no channel A audio (entertainment program and intercom signals) is fed to No. 1 channel A speaker through its red and red/white terminals.

(9.1.3) The red lead from channel A speaker is connected through S101F-7 and LI terminal S101F-10 to one side of the intercom only path on the Parent Board.

(9.1.4) The red/white lead from channel A speaker is connected through S101F-1 and LI terminal S101F-4 to the other side of the intercom only path on the Parent Board.

(9.1.5) The intercom only path is connected through J101-2/P601-2 and J105-4/P601-4 to the intercom input transformer T601 on the PRE-AMPLIFIER MODULE.

(9.2) Sounds in the vicinity of the No. 1 channel A speaker will be fed through the transformer; amplified and fed to all other I/P speakers that are operating in the RADIO/INTERCOM mode.

(9.2.1) SINCE NO TALK OR LISTEN SWITCH AT ANY I/P SPEAKER IS BEING ACTIVATED, THERE WILL BE NO MUTING.

(9.2.2) The signals from the speaker in LI mode must override the entertainment program to the channel A speakers that are operating in RI mode. (See, under OPERATIONAL CHECKOUT: paragraph (8), page 7 through paragraph (8.4), page 9; and under PREAMP MODULE, paragraphs (20) through (20.7.1), page 26.)

(9.3) Speakers that are in LI can activate its DOOR TALK switch S2A/S2B and speak to the door speaker(s), but even if it activates its DOOR LISTEN switch S1, it can not hear signals from the door speaker(s).

(9.4) Speaker in LI can not hear intercom messages originated by other I/P speakers.

(9.5) Speaker operating LI can activate its I/P TALK switch S4A/S4B and send messages — with regular key-click and entertainment program muting — to all other I/P speakers that are operating in the RADIO/INTERCOM or STANDBY mode.

(9.5.1) Speaker operating LI, can activate its I/P LISTEN SWITCH S3A/S3B and hear "Hands Free" answer from the other I/P speakers that are operating in RI or STBY mode.

(10) SPEAKER NO. 1 IN OFF MODE:

(10.1) THROW SPEAKER OPERATING MODE SWITCH S101 TO OFF MODE.

(10.1.1) No. 1 channel B speaker's blue lead will be open at S101R-5 and the speaker will be OFF.

(10.1.2) The No. 1 channel A speaker's output (red) line is open-ended at S101F-7; and its output ground (red/white) line is open-ended at S101F-1.

(10.1.2.1) The No. 1 channel A speaker is OFF and will not receive: channel A's entertainment program; chime and/or alarm signals; TALK signals from other I/P speakers; and TALK or LISTEN signals from door speaker(s).

(10.2) If DOOR LISTEN switch S1 is activated, the Control Line will be connected — through No. 1 speaker control's orange and orange/white leads; and the intercom input transformer T601's center-tap — to ground. (See paragraphs (5.1) through (5.4.2) above.)

(10.2.1) Systems key-click muting will be activated and the entertainment program (both channels) will be muted. Sounds in the vicinity of the door speaker(s) will not be heard at speaker No. 1, but will be heard by other I/P speakers which are operating in RI or STBY mode.

(10.3) If No. 1 speaker's DOOR TALK switch S2A/S2B is activated, the door speaker(s) will be connected — through the black and black/white leads — to the controls red and red/white wires, but since these wires are open-ended at S101F-7 and S101F-1, the door speaker(s) will not receive channel A signals.

(10.3.1) The Control Line will remain open and there will be no key-click nor entertainment program muting. (See paragraphs (4.1) through (4.3.2); and (4.6) through (4.6.2) above.)

(10.3.2) When S2A/S2B is activated, the No. 1 channel A speaker is connected through the orange and orange/white leads to the intercom input transformer T601. (See paragraphs (4.4) through (4.5.2) above.)

(10.3.3) Sounds in the vicinity of speaker No. 1 will be amplified through the intercom preamp Q612 and the CHANNEL A AUDIO POWER AMPLIFIER, and with no muting, the signals will be mixed with the entertainment program and heard at all channel A speakers that are operating in the RI mode.

(10.3.3.1) The ratio of the audio levels will be the same as when Speaker No. 1 operates in LISTEN-IN mode. (See paragraphs (9.2.1) and (9.2.2) above.)

(10.4) If speaker No. 1's I/P TALK switch S4A/S4B is activated, its channel A speaker will be connected — through the orange and orange/white paths — across the intercom input transformer T601.

(10.4.1) Since the red and red/white paths are open-ended at S1-1F-7 and S101R-5 the Control Line is not grounded, and there will be no key-click nor entertainment program muting.

(10.4.2) The sounds in vicinity of No. 1 channel A speaker will operate same as shown in paragraphs (10.3.3) and (10.3.3.1) above.

(10.5) If, while in the OFF mode, speaker No. 1's I/P LISTEN switch S3A/S3B is activated, its channel A speaker will be connected to the orange and orange/white leads.

(10.5.1) The Control Line will be connected through the 10 Kohm resistor R2 to ground and the CONTROL CIRCUIT will operate the same as when the speaker is operating in the RI or STBY Mode and S3A/S3B is activated. (See paragraphs (7) through (7.6) above.)

(10.5.2) This allows a speaker that is in the OFF mode to monitor I/P speakers that are operating in the radio intercom or standby modes.

SYSTEM SERVICING

(1) Before attempting servicing of the SM-428 system, the technician should be familiar with the OPERATIONAL CHECKOUT (pages 5-10) and the THEORY OF OPERATION (pages 11-38) of this manual.

(2) The system should be capable of completing every step of the OPERATIONAL CHECKOUT.

(2.1) When the system is checked, step-by-step, it can more easily be determined in which circuit (or circuits) the mal-function is located.

(3) In the THEORY OF OPERATION, each circuit (module) is treated independently, and when a particular module is suspected, it can be serviced according to the information included in its section. (See TABLE OF CONTENTS, page 2 for the individual sub-headings under the THEORY OF OPERATION.)

(3.1) Individual schematic diagram, voltage chart, and PC board layout are included with the section dealing with the respective module. The complete system schematic is shown in Figure 24, fold-out pages 52-54 and 55-57.

(4) The voltages shown in this manual were observed on a production unit and were measured with a high-impedance input, digital read-out meter.

(4.1) A standard 20 kohm per volt multi-meter may be used for relatively accurate measurements, but suggest that a high-impedance input meter such as a digital readout or VTVM meter be used when available.

(4.2) Measured voltages may vary $\pm 10-20\%$ in an individual set, but the relationship between the various potentials should be as shown.

(5) When servicing units in the field, a suspected defective module may be replaced, and later "Bench serviced" as shown in its individual section in the THEORY OF OPERATION.

(5.1) Most operating voltages can be made with the set installed and opened out as shown in Figure 9, page 8.

DISASSEMBLY

(1) REMOVING MASTER UNIT:

(1.1) Extract Phillips head retaining screws in upper left and upper right corners—through front panel.

(1.2) Tip the complete chassis down and hold in a horizontal position with the support strap.

(1.3) Disconnect the tuner's coaxial antenna lead-in from the antenna terminal strip in the IR-14 Rough-in Housing. (Figure 9, page 8)

(1.4) Disconnect the Master Unit's green ground wire at the grounding terminal in the Rough-in Housing.

(1.5) Disconnect one of the 12Vac power wires from the power transformer (T101) from one of the black wires (through the in-line fuse F101).

(1.5.1) INSULATE THE END OF THE 12VAC WIRE THAT COMES FROM THE TRANSFORMER T101.

(1.6) Disconnect the other 12Vac power wire from the transformer from the other black wire to the Master Unit Parent Board.

(1.6.1) INSULATE THE END OF THIS WIRE COMING FROM THE POWER TRANSFORMER.

(1.7) DO NOT SHORT THE 12VAC WIRES THAT ARE CONNECTED TO TRANSFORMER T101. THE SECONDARY OF THIS TRANSFORMER IS PROTECTED BY A NON-REPLACEABLE 5 AMP FUSE. IF THE WIRES ARE SHORTED, THE FUSE WILL BLOW AND THE TRANSFORMER WILL HAVE TO BE REPLACED.

(1.8) If the system includes the Model ISA-47 5-Inch Speaker/Clock Timer, disconnect its protective circuit's J31 from P31.

(1.9) If the system includes a record player, disconnect its shielded cables from PHONO jacks J108 and J109. Pull plugs straight out.

(1.9.1) Make certain that the record player's left channel cable and right channel cable can be identified.

(1.10) If the system includes a tape player, disconnect its shielded cables from the TAPE-IN jacks J110 and J111. Pull plugs straight out.

(1.10.1) Make certain that the tape player's left channel cable and right channel cable can be identified.

(1.11) If an auxiliary program source is use, disconnect its shielded cable from the AUX jacks J112 and J113. Pull plugs straight out.

(1.11.1) Make certain that the auxiliary program source's left channel cable and right channel cable can be identified.

(1.12) If entertainment program is being fed to a tape recorder for recording, remove the tape recorder's cables from TAPE OUT jacks J114 and J115.

(1.12.1) Make certain that the recorder's left input cable and right input cable can be identified.

(2) REMOVING MASTER UNIT WITHOUT DISCONNECTING THE INTERCONNECTING WIRES AND CABLES AT THE TERMINAL BOARD.

- (2.1) Complete steps (1) through 1.12.1) above.
- (2.2) See Figure 9, page 8. Remove the TERMINAL BOARD mounting screws E.
- (2.3) Lift the complete TERMINAL BOARD ASSEMBLY with the interconnecting wires and cables intact, disconnecting J801, J802, and J803 from P106, P105 and P102 respectively.
- (2.3.1) Carefully stow the TERMINAL BOARD with wires attached in the rough-in hosing.

(3) REMOVING MASTER UNIT COMPLETE WITH THE TERMINAL BOARD.

- (3.1) Complete steps (1) through (1.12.1) above.
- (3.2) Remove the twisted pair(s) from the door speaker(s) from the DOOR terminals on the TERMINAL BOARD.
- (3.3) Remove the color-coded wires of the four twisted-pair cables and/or the color-coded wires of the three twisted-pair cables (when used) from the I/P Speaker Controls at their respective color-coded terminals.
- (3.3.1) Mark these wires for identity. (Speaker No. 1, Speaker No. 2, et al).
- (4) After completing paragraphs (1) and (2) or paragraphs (1) and (3) above: Unhook support strap from rough-in housing and lift unit and moveable leaf up and away from the fixed leaf of each hinge that is fastened to the rough in-housing.
- (4.1) Do not remove the hinge leaf from the rough-in housing. These leaves may be adjusted by loosening the mounting screws, and tightening when adjustment is completed.

(5) REPLACING INDIVIDUAL MODULES

- (5.1) The plug-in modules:
Power Supply
FM Multiplex Decoder
Dual Audio Preamp & Intercom Preamp
Channel A Audio Power Amplifier
Channel B Audio Power Amplifier
may be removed by pulling straight out from the Parent Board.
- (5.1.1) The Master Unit is shipped with these boards secured in place by elastic bands around the plastic PC board guides.
- (5.1.2) If these elastic bands were left in place when system was installed, they should be removed before unplugging the modules.
- (5.1.3) If desired, to secure modules and supports, the elastic bands may be reinstalled after the new or repaired module is reinserted in the Parent Board.

(5.2) CONTROL MODULE:

- (5.1.2) Remove Control Module mounting screws D and gently but firmly lift PC board straight up and away from Master Unit chassis.
- (5.1.3) Do not lose the plastic standoff that is installed on P104. This standoff prevents shorting of the Control Module to the Parent Board.

(5.3) AM/FM TUNER MODULE:

(5.3.1) Removing complete Tuner Assembly:

- (5.3.1.1) Remove AM/FM TUNING KNOB (Figure 8, page 5), pull straight forward.
- (5.3.1.2) Disconnect shielded antenna lead-in from antenna terminal strip in rough in-housing.
- (5.3.1.3) Remove Control Module as directed in paragraphs (5.2) through (5.1.3) above.
- (5.3.1.4) Remove Radio Assembly mounting screws A and while disconnecting J1 from P101, and J6 from P107, lift Radio Assembly away from Master Unit chassis just far enough to gain access to pilot lights I104, I105, and I106.
- (5.3.1.5) Remove the three lights from the dial frame. (Note: a small screw driver may be used to gently pry light socket keys out of slots in frame—use care.
- (5.3.1.6) Lift complete Radio Assembly out of the Master Unit.

(5.3.2) Replacing Tuner PC Board only:

- (5.3.2.1) Set tuning indicator to lowest frequency, i.e. maximum capacity—ganged tuning capacitor C303 fully closed.
- (5.3.2.2) To eliminate the necessity of restringing the dial cord, using masking tape secure the cord to the capacitor flywheel.
- (5.3.2.3) Remove the flywheel retainer screw C, bushing, and retainer ring: Slide the flywheel off the capacitor shaft. Secure the flywheel to dial frame—do not change its orientation.
- (5.3.2.4) Remove the two PC board-to-dial frame mounting screws B.
- (5.3.2.5) Remove the mounting screw A that holds the top corner of the tuner PC board to the Master Unit.
- (5.3.2.6) Pull the tuner PC board straight out from the chassis—disconnecting J6 from P107, and J1 from P101. Do not lose the flexible standoff that is on P107.

(6) REPLACING PILOT LIGHTS

- (6.1) Complete paragraphs (5.3) through (5.3.1.5) above.
- (6.2) Remove pilot lamps from sockets by pulling straight out.

(6.2.1) The pilot lamps I104, I105, and I106 are connected in series. Check lamps with ohm meter for continuity to determine which lamp(s) is/are defective.

(6.3) Replace defective lamp(s).

(6.4) Reassembly by reversing above. Make certain that wiring to lamps does not interfere with reassembly.

(7) REMOVING MASTER UNIT PARENT BOARD

(7.1) The Parent Board should be removed from the Master Unit only during "In-shop bench service."

(7.2) The Parent Board must be removed from the Master Unit in order to replace any of the components shown with the PC layouts of Figure 22, page 45/46; and Figure 23, page 47/48.

(7.2.1) These components are shown as "100" series part numbers in the Schematic Diagram, Figure 24, pages 52/53/54-55/56/57.

(7.3) NOTE: Use Figure 22 when checking Parent Board's foil path for continuity or open in signal or power paths.

(7.4) Remove Master Unit from installation by completing paragraphs (1) through (4.1) above.

(7.5) See Figure 8, page 5; Remove the AM/FM TUNING KNOB; PROGRAM SELECTOR KNOB; ten SPEAKER MODE SWITCH KNOBS; and the four tandem control knobs—TREBLE, BASS, VOLUME, and BALANCE.

(7.5.1) Pull all knobs straight forward.

(7.5.1.1) If knobs are difficult to remove, they may be pried gently with a small screw driver whose blade is protected by a cloth wrapping so that it does not mar the front panel.

(7.6) Lay the Master Unit, face down, on a soft protective cloth so that front panel is not marred.

(7.7) If Master Unit was removed from installation with its Terminal Board, remove Terminal Board mounting screws E and pull Terminal Board straight out from chassis. (See Figure 9, page 8)

(7.8) Remove all other Modules. Complete paragraphs (5) through (5.3.1.6) above.

(7.8.1) Gently stow these Modules so that they are protected while working on the Parent Board.

(7.9) Remove all Parent Board mounting screws G. (See Figure 9, page 8)

(7.10) Gently lift Parent Board out of chassis.

(7.10.1) When replacing Parent Board, make certain that the shafts of all controls are centered in their opening through front panel, and reverse procedure listed above.

(8) REPLACING FRONT PANEL ASSEMBLY:

(8.1) Complete Parent Board removal as shown in paragraphs (7) through (7.10) above.

(8.2) EARLY PRODUCTION UNITS: Remove the retainer screws and washers from around perimeter of Front Panel.

(8.2.1) LATER PRODUCTION UNITS: Pull staples and remove retainer blocks from around perimeter of Front Panel.

(8.3) Lift Front Panel Assembly out of chassis.

(8.4) Make certain that new panel is square and even in frame and secure in place with screws or retainer blocks.

TROUBLE SHOOTING

(1) SYSTEM DEAD—NO PILOT LIGHTS

CHECK: 12Vac in-line 3 amp Fuse F101.
12Vac between terminals **mm** and **ll**
12Vac secondary of T101.
Open secondary of T101—built-in 5 amp fuse blown?
120Vac supply to T101.
ON/OFF SWITCH S112.

(2) SYSTEM ON—NO PILOT LIGHTS BEHIND TUNER DIAL—LIGHT I101 BEHIND TUNING METER ON

CHECK: 12Vac between terminals **oo** and **pp** on Parent Board. (Figure 22)
Wiring between **oo** and **pp** and pilot light assembly on tuner frame.
Individual lamps I104, I105, and I106—lamps connected in series, if one is out, all are out
Individual lamp contact in its socket.

(3) SYSTEM ON—PILOT LIGHTS BEHIND TUNER DIAL ON—LIGHT I101 BEHIND METER OFF

CHECK: For 12Vac across I101 socket on Parent Board. (See Figure 22)
If voltage is present, check lamp I101.

(4) NO FM—ALL OTHER FUNCTIONS NORMAL

CHECK: FM antenna connections at Antenna Terminal Strip, through coaxial cable to Tuner PC Board. Make certain that cable is not shorted to ground on PC Board.
Program Selector Switch S111R-10; S111F-9;
12Vdc at S111R-4.
Regulated 12Vdc at J1 3/P101-3.
17Vdc at P701-4/J103-4.
If Tuning Meter I103 indicates zero or very low reading, check Q301, Q302, IC301, FM audio output at J1-4/P101-4.
FM audio input at P701-5/P103-5.
Operating voltages on Tuner Module (see page 13) and on MPLX Module (see page 21)

(5) NO AM—ALL OTHER OPERATIONS NORMAL

CHECK: Antenna connections at rough-in housing's antenna terminal strip.
Antenna connections on Tuner PC Board.
AM's regulated 12Vdc at S111R-5.
AM audio signal at S111R-11 and S111F-10.
AM audio out at J1-1/P101-1.
Check 12Vdc at J1-2/P101-2; operating voltages on Tuner PC Board (see page 13).
Q303 and IC302.

(6) NO SOUND AT I/P SPEAKERS.

CHECK: Speaker Operating Mode Switches S101-S110.
I/P Speakers' cable connections at Master Unit Terminal Board.
Speaker wiring connections at Individual I/P Speaker Controls.
Connections at terminals 1 and 2 at J2A/P104.
Check that muting is not on. Voltage at base of Q101, Q606, Q611 and Q612 should be zero.
Master Unit VOLUME control and Volume control at I/P Speakers.

(7) DISTORTION AT ALL SPEAKERS.

CHECK: Setting of Master Unit VOLUME control and volume controls at I/P Speakers. (See paragraphs (3.9) and (4) through (5.2), pages 6 and 7).
Operating voltages to preamp at J105-6/P601-6 and J107-27/P602-27.
Preamplifier operating voltages (see page 24.)
Channel A and Channel B Audio Amplifiers' operating voltages (see page 29).

(8) RECORD PLAYER AND/OR TAPE PLAYER SILENT—ALL OTHER OPERATIONS NORMAL

CHECK: PROGRAM SELECTOR SWITCH S111.
Record Player and/or Tape Player.
Shielded audio leads between Record Player and/or Tape Player and their correct input jacks on the Parent Board.

(9) HUM WHEN SELECTOR SWITCH IS IN PHONO OR TAPE POSITION—ALL OTHER OPERATIONS NORMAL

CHECK: Shielded cable between Phono and/or Tape Player and Master Unit Parent Board and connections thereto.
Ground wire of Phono and Tape Player Rough-in Housing should be connected to the ground screw in the Master Unit's Rough-in Housing.

(10) NO MUTING DURING INTERCOM OPERATION—ALL OTHER FUNCTIONS NORMAL.

CHECK: DC voltage at P103-14/J2B-14 and at P103-15/J2B-15. Control Module quiescent and operating voltages (see page 33).
Audio Muting voltage at P103-13/J2B-13.
Key Click Muting voltage (when listen switch is opened or closed) at P103-12/J2B-12.
Transistors on Control Modules.
Muting Transistors Q101, Q606, Q611, and Q612 and base voltage thereto when switch is operated.

(11) MUTING ON—NO TALK OR LISTEN SWITCH IS BEING ACTIVATED

CHECK: For shorted Control Line (black or black/white speaker wire). Impedance point "X" to ground should be very high.
Voltage at point "X" on Control Module. Should be in the order of 0.86 volts when no switch is being operated.

For closed or shorted talk listen switch at one or more of the I/P Speakers.
Short between black or black/white and one of the orange wires or red wires in one or more speaker cables.
If system includes ISA-47 Speaker/Clock Timer, make certain unit is ON (see paragraphs (11)-(11.3.4), page 10).
For emitter/collector short in Q401.

(12) SIGNALS FROM CHIME AND/OR ALARM AND FROM SPEAKERS IN "LISTEN IN" MODE IS TOO LOW.

CHECK: Setting of LEVEL SET CONTROLS R617 and R640 (see paragraphs (8) through (8.4), pages 7-9).

(13) NO INTERCOM SIGNALS FROM ANY SPEAKER OPERATING IN ANY MODE—ALL OTHER OPERATIONS NORMAL.

CHECK: Intercom Input Transformer T601; D602; D601; Q601; Q612; and associated circuitry.

(14) DOOR SPEAKERS CAN NOT RECEIVE NOR TRANSMIT INTERCOM SIGNALS—ALL OTHER OPERATIONS NORMAL.

CHECK: Door Speaker wiring, and connections at black and black/white terminals on Terminal Board, or at black and black/white terminals in I/P Speaker Door Speaker.
Door Talk and Listen switches in I/P Speaker(s)

(15) ALL I/P SPEAKERS CAN TRANSMIT INTERCOM CALLS, BUT CANNOT RECEIVE "HANDS FREE" ANSWER.

CHECK: Talk/Listen Relay K401.
Q402
R404, R405, R406, and C401
Voltage at point "Y" when I/P LISTEN switch is activated, should be approximately 10.5Vdc.

(16) WHEN I/P SPEAKER IS IN STANDBY MODE, IT CANNOT RECEIVE NOR TRANSMIT INTERCOM SIGNALS—OTHER OPERATIONS NORMAL

CHECK: Speaker Operating Mode Switches S101-S110.
Standby Relay K402
Q403, R408, R409

(17) HIGH PITCH SQUEL

CHECK: For shorts between input and output speaker wires and terminals (red and orange pairs).

(18) LOW FREQUENCY FEEDBACK BETWEEN SPEAKERS DURING INTERCOM OPERATION

CHECK: Volume setting of the offending speakers. Speakers must not be installed back-to-back on a common wall.
Reduce volume of different speakers to determine acoustic feedback between individual speakers.

SM428 SYSTEM REPLACEMENT PARTS LIST

RESISTORS: Value in ohms $\pm 5\%$, $\frac{1}{4}$ watt, Carbon Film, unless otherwise noted.

K = Kilo = (10^3)

M = Mega = (10^6)

CAPACITORS: Value in micro (10^{-6}) farads $\pm 10\%$, 500WVDC, Ceramic Disc, unless otherwise noted.

ρ = pico = (10^{-12})

| Schematic Symbol | NuTone Part No. | Description | Schematic Symbol | NuTone Part No. | Description |
|-------------------------------------|-----------------|--|-------------------|-----------------|--|
| MODEL SM-428 MASTER UNIT | | | | | |
| | 38823-000 | Frame | 1104, 1105, 1106 | 39330-000 | Lamp, 6.3V, .250A, Wedge Base, Type #259 (series connected pilot lights) |
| | 42001-000 | Front Panel Assembly | | 42103-000 | Socket and Wire Assembly using Molex type SDX-6013 wedge type sockets, for use with 1104, 1105, and 1106 |
| | 41999-000 | Frame & Front Panel Assy. | CONNECTORS | | |
| | 39620-036 | Hinge Leaf (2 required) | J101, J102 | 39339-101 | Receptacle, 5-pin PC board mounting, Molex type A-2145-5B (for Audio Power Amplifier Modules) |
| | 28031-015 | Screw, #8 \times $\frac{3}{8}$ " Ph Hex/W "A" Hinge Leaf Mounting | J103 | 39339-108 | Receptacle 6-pin PC board mounting, Molex type A-2145-6B (for FM MPLX Decoder Module) |
| | 39624-000 | Knob, AM/FM Tuning | J104 | 39339-103 | Receptacle, 8-pin PC board mounting, Molex type A-2145-8B (for Power Supply Module) |
| | 39627-000 | Knob, Program Selector Switch | J105 | 39339-107 | Receptacle, 15-pin PC board mounting, Molex type, A-2145-15B (for Dual Stereo Preamplifier and Intercom Preamp Module) filling space for J105 and J106 (pins 1 to 15) as shown on PC board layout in Figures 22 & 23 |
| | 39626-000 | Knob, Speaker Operating Mode Switch, (10 required) | J106 | Not Used | |
| | 39625-000 | Knob, Treble; Bass; Balance; and Volume Controls, (4 req.) | J107 | 39339-110 | Receptacle, 12-pin PC board mounting, Molex type A-2145-12B (for Dual Stereo Preamplifier and Intercom Preamp Module, pins 16-28) |
| | 38825-000 | Lens, engraved, AM/FM Tuning Dial | J108-J115 | 39595-000 | Receptacle, RCA shielded phono jack type for PC board mounting |
| | 38828-000 | Lens, FM Stereo/Mono Indicator | P101 | 39338-101 | Plug, 5-pin, PC board mounting, Molex type A2461-5D (for AM/FM Tuner Module) |
| PARENT PRINTED CIRCUIT BOARD | | | P102 | 39338-101 | Same as P101 (for Terminal Board pins 1 to 5) |
| | 42002-000 | Complete Assembly | P103 | 39338-102 | Plug, 7-pin PC board mounting, Molex type A-2461-7D (for Control Module, pins 9 to 15) |
| | 90029-004 | Mounting Screws, #6 \times 38" Ph. Tr. "A" (12 required) | P104 | 39338-103 | Plug, 8-pin PC board mounting, Molex type A-2461-8D (for Control Module, pins 1 to 8) |
| | 31984-000 | Clamp, cable, for power wiring and ground wire. | P105, P106 | 39338-105 | Plug, 15-pin PC board mounting, Molex type A-2461-15D (for Terminal Board: pins 6 to 20; and pins 21 to 35) |
| | 39387-003 | Screw, #6 \times $\frac{5}{8}$ " Ph. Pan 25" Cable Clamp Mounting | P107 | 39338-108 | Plug, 3-pin PC board mounting, Molex type A-2461-3D (for AM/FM Tuner Module to Tuning Meter) |
| | 39612-000 | Plastic Guide/Support for PC boards. Amp. type #58325-1. For Power Amplifier, Preamplifier; Power Supply; and Multiplex Modules. | TRANSISTOR | | |
| CAPACITORS | | | Q101 | 36613-000 | NPN, SILICON, muting switch to input of Channel B Audio Power Amplifier Motorola MPS-A20 Texas Inst. TIS-098 |
| C101, C102 | 35100-180 | 47pf | | | |
| C103, C104 | 35101-142 | 15pf, Temperature Compensated | | | |
| C105 | 35055-101 | .47 \pm 20%, 100 WVDC, Polyester Film | | | |
| C106 | 35100-127 | .1, +80%, -20%, 200 WVDC | | | |
| C107, C108 | 35100-188 | 100pf | | | |
| C109 | 35100-142 | 330pf | | | |
| FUSE | | | | | |
| F101 | 39664-000 | 3 Amp., 250V, Fast-Blow, Type AGC3 | | | |
| | 42000-000 | Fuseholder and Wire Assembly for F101 | | | |
| INDICATORS | | | | | |
| I101 | 39611-000 | Lamp, 14V, .08A, GE type #73 Tuning Meter Illuminator | | | |
| | 39610-000 | Socket, Lamp, Elecon type #1818, for I101 | | | |
| I102 | 31813-000 | Lamp, 12V, .035 - .045 Amp., Type #12ESB, FM Stereo Indicator | | | |
| | 31815-000 | Socket, Lamp, Sylvania type BO150, for I102 | | | |
| I103 | 36105-000 | Meter, 0-200 microA dc \pm 10%, Mura Meters type #YN-40, AM/FM Tuning Indicator | | | |

| Schematic Symbol | NuTone Part No. | Description |
|------------------|-----------------|---|
| RESISTORS | | |
| R101, R102 | B-34660 | Variable, 100Kohm \pm 20%, 1/2 watt, slide type, modified logarithmic taper: 20% R at 50% travel, Channels A and B Volume Control Stackpole type 5020 Original production: White Shaft Intermediate production: White Shaft Later production: Red Shaft CHECK PART NUMBER ON CASE. |
| R103, R104 | B-34661 | Variable, 100Kohm \pm 20%, 1/4 watt, slide type, Modified linear taper: 53% R at 25% travel; 95% R at 50% travel; 97% R at 75% travel, Channels A and B Balance Control Stackpole type 5005R Original production: White Shaft Intermediate production: Black Stripe Later production: Blue Shaft CHECK PART NUMBER ON CASE |
| R105, R106 | B-34662 | Variable, 100Kohm \pm 20%, 1/4 watt, slide type, modified logarithmic taper: 10% R at 25% travel; 27% R at 50% travel; 48% R at 75% travel, Channels A and B Bass Control Stackpole type 6535 Original production: White Shaft Intermediate production: Red Stripe Later production: Black Shaft CHECK PART NUMBER ON CASE |
| R107, R108 | B-34663 | Variable, 100Kohm \pm 20%, 1/4 watt, slide type, modified logarithmic taper: 4% R at 25% travel; 12% R at 50% travel; 30% R at 75% travel, Channels A and B Treble Control, Stackpole type 6515 Original production: White Shaft Intermediate production: Blue Stripe Later production: White Shaft CHECK PART NUMBER ON CASE |
| R109, R118, R119 | 33082-470 | 47 |
| R110, R111 | 33082-102 | 1K |
| R112, R113 | 33082-474 | 470K |
| R114 | 33082-103 | 10K |
| R15 | 33101-103 | 10K \pm 10%, 1/2 watt, Carbon Comp. |
| R116, R117 | 33082-105 | 1M |
| R120, R121 | 33082-684 | 680K |
| R122, R123 | 33082-472 | 4.7K |
| R124 | 33101-331 | 330 \pm 10%, 1/2 watt, Carbon Comp. |
| R125 | 33082-101 | 100 |
| SWITCHES | | |
| S101-S110 | 34664-000 | Rotary, non-shorting contacts, 4-position, OAK Mfr. #521521-348. Speaker Operating Mode |
| | 39626-000 | Knob, for S101-S110 |
| S111 | 34665-000 | Rotary, non-shorting contacts, 5-position. PROGRAM SELECTOR Standard Grigsby Co. #45462-4MLR-1 |

| Schematic Symbol | NuTone Part No. | Description |
|------------------------------------|------------------------|--|
| S112, S13 | 39627-000 39666-000 | Knob, for S111 Slide type, DPDT, 0.5Adc, 0.3Aac, 125V Switchcraft #4606L POWER ON/OFF; MONO/ STEREO |
| TRANSFORMER | | |
| T101 | 42055-000 | Power, 120Vac, 60 hz. Primary; Secondary 12.3Vac @ d-c output of 1.9Aavg; 30 VA. Secondary protected by non-replaceable 5A fuse. (Supplied with IR-14) Better Coil & Transformer #PN-10520-PI |
| INTEGRATED CIRCUIT | | |
| Z101 | 36648-000 | 3-terminal, Positive Voltage Regulator: Output 12Vdc (11.1V to (12.9V) with internal short circuit current limiting and thermal overload protection Motorol #78L12CP Fairchild #78L12WC |
| DC POWER SUPPLY MODULE | | |
| | 42016-000 | Complete Assembly |
| CAPACITORS | | |
| C201, C202 | 35091-108 | 100, +100%, -10%. 25WVDC Electrolytic |
| C203, C204 | 35091-107 | 1000, +100%, -10%, 35WVDC Electrolytic |
| C205 | 35091-114 | 100, +100%, -10%. 50WVDC Electrolytic |
| C206, C207 | 35091-105 | 470, +100%, -10%, 25WVDC Electrolytic |
| C208-C212 | 35100-139 | .01, +80%, -20%, 50 WVDC |
| DIODES | | |
| D201, D202 | 36549-000 | Silicon Rectifier, 1Adc, 100PIV, 1N4002 |
| D203-D206 | 36608-000 | Silicon Rectifier, 3Adc, 100PIV, General Instrument 1N540Z Motorola MR-502 |
| D207, D208 | 36539-000 | Silicon Zener. 12V \pm 5% 1N4742A |
| CONNECTOR | | |
| P201 | 39619-103 | Plug, 8-pin, PC board mounting, Molex type A-2373-8M |
| RESISTORS | | |
| R201 | 33101-100 | 10 \pm 10%, 1/2 watt, Carbon Comp. |
| R202 | Not Used | |
| R203 | 33039-101 | 100 \pm 10%, 1 watt, Wire Wound |
| R204 | 33101-470 | 47 \pm 10%, 1/2 watt, Carbon Comp. (Early production units) |
| R204 | 33101-101 | 100 \pm 10%, 1/2 watt, Carbon Comp. |
| AM/FM RADIO TUNER MODULE | | |
| | 42004-000 | Complete Assembly |
| AM/FM PRINTED CIRCUIT BOARD | | |
| | 42007-000 | Complete Assembly |

(Parts List continued on page 49)

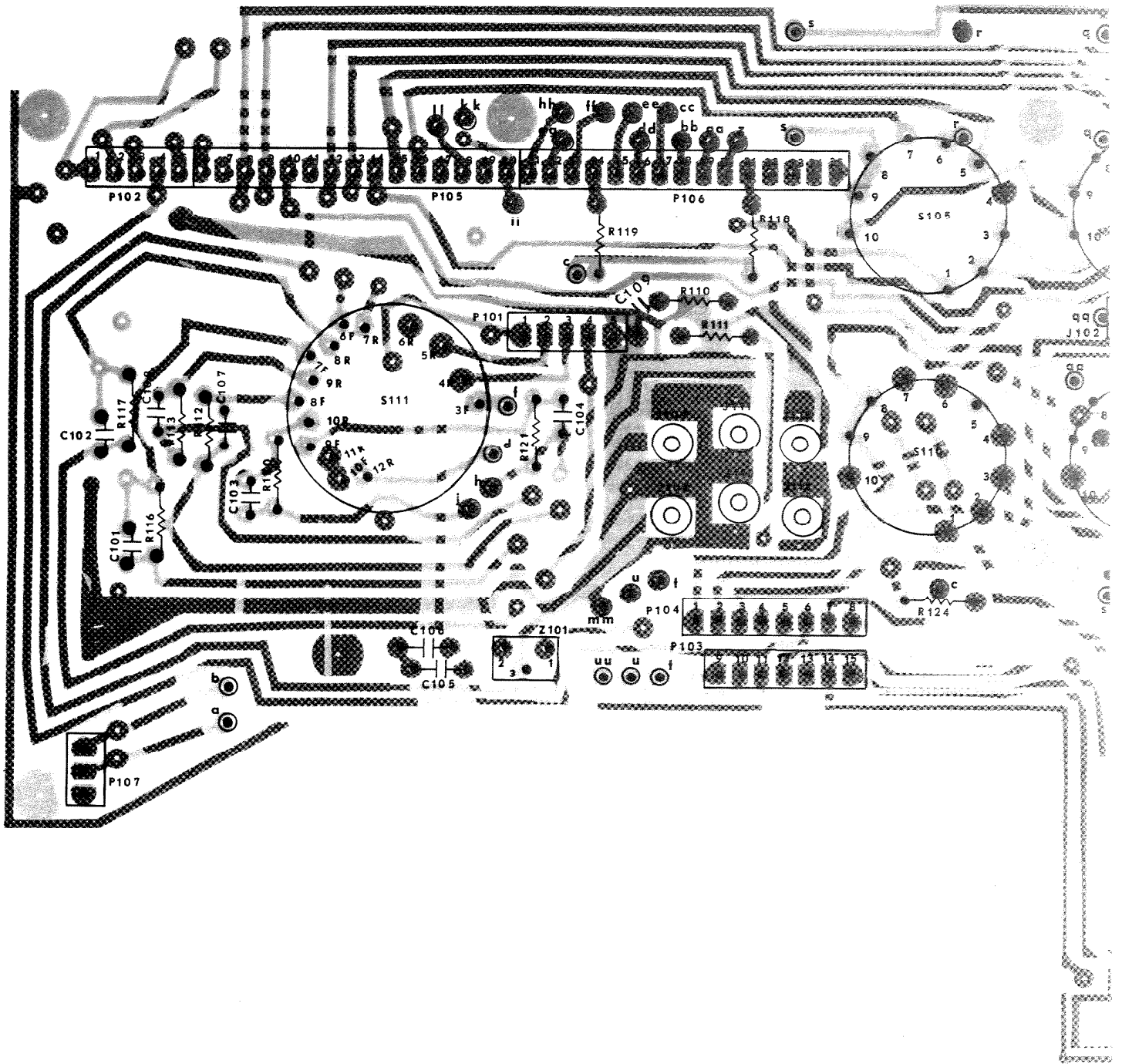

PARENT BOARD — RE/
FOIL PATH/COMPONENT C

LIGHT FOIL PATH: FRONT SIDE OF BOARD AS VIEWED (

FIGURE 22

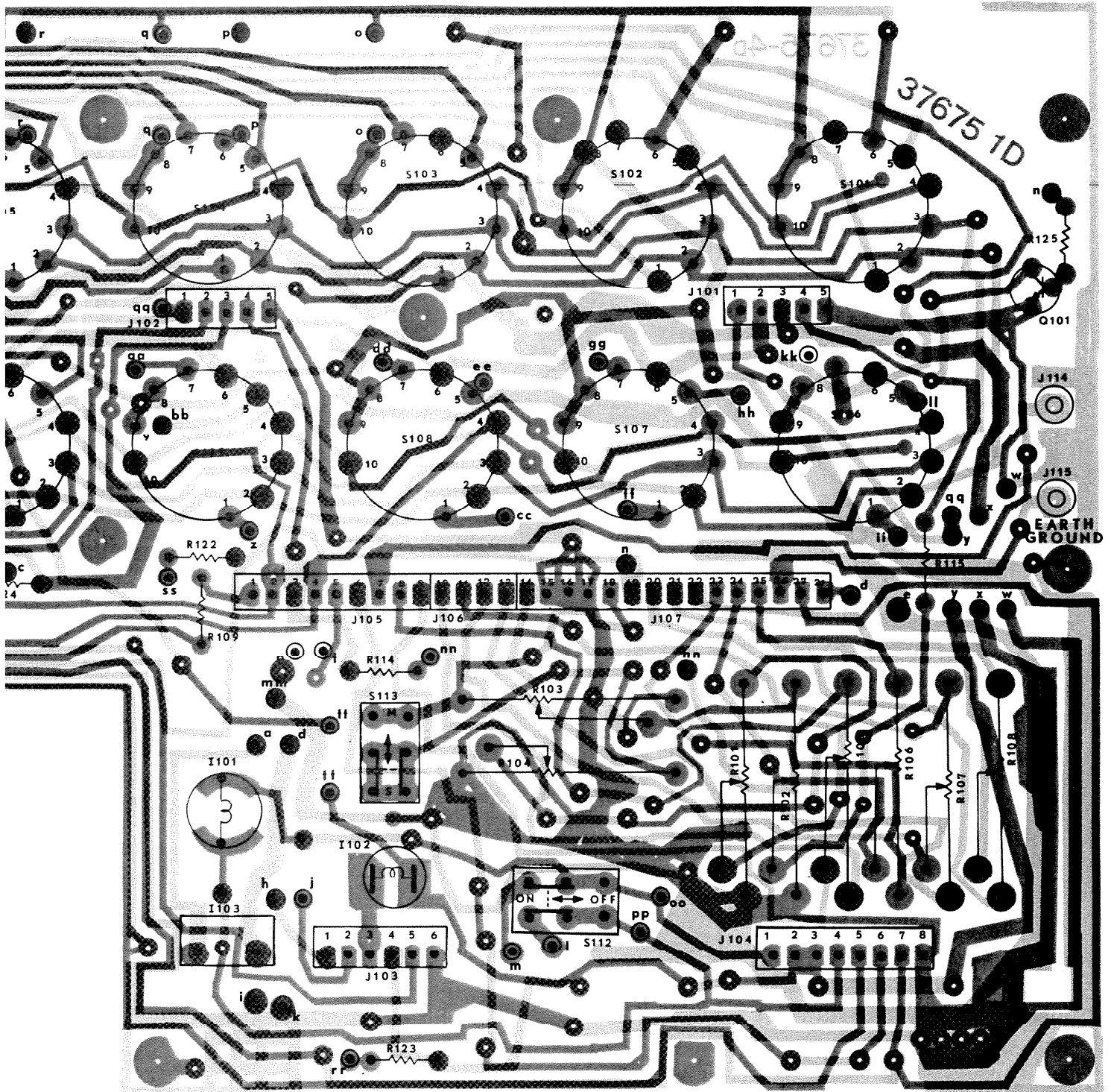

Γ BOARD — REAR VIEW
COMPONENT CONNECTION

BOARD AS VIEWED (SEE THROUGH) FROM REAR OF BOARD

FIGURE 22

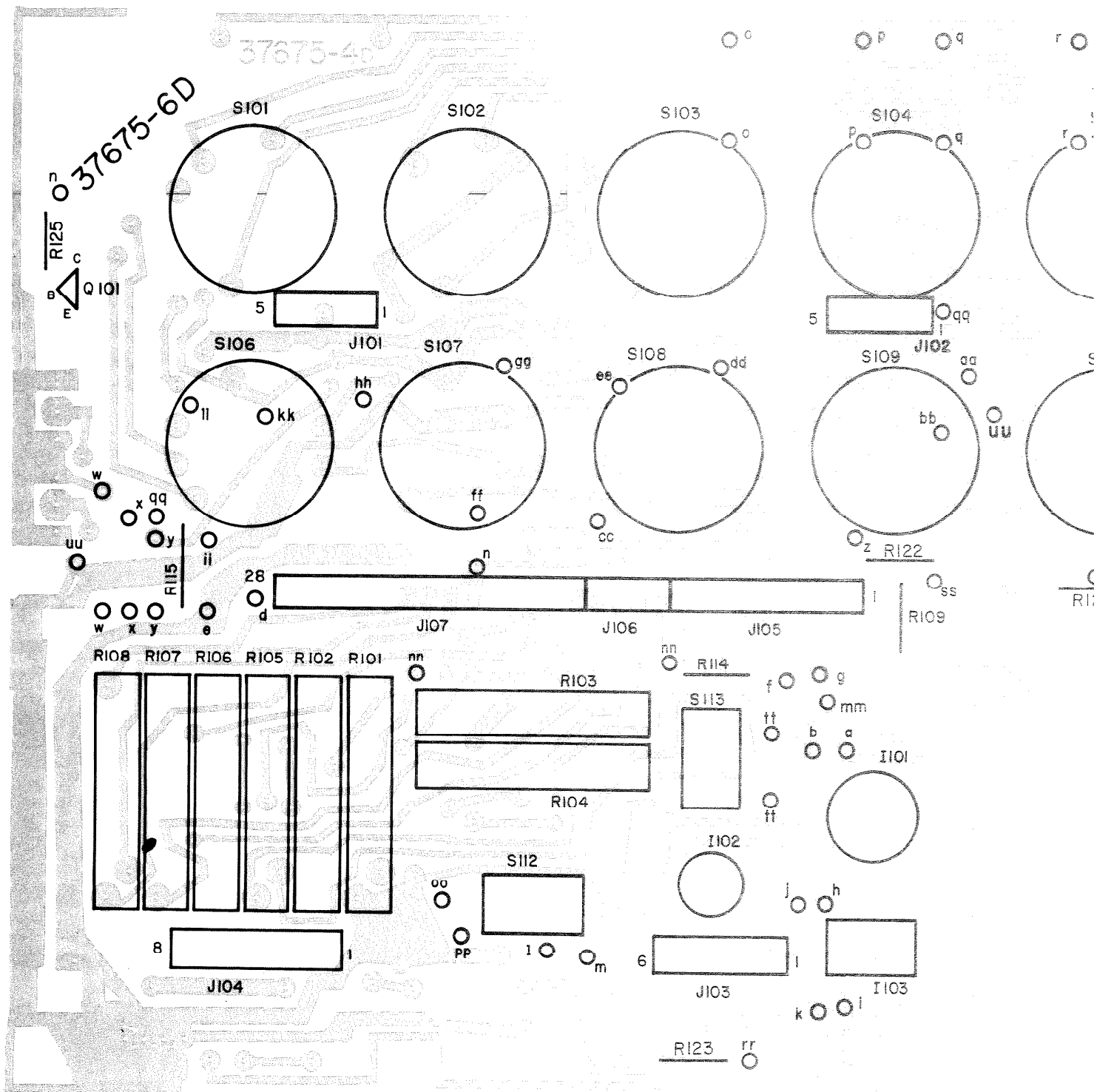

PARENT BOARD — FRO
FOIL PATH/COMPONENT

FIGURE 23

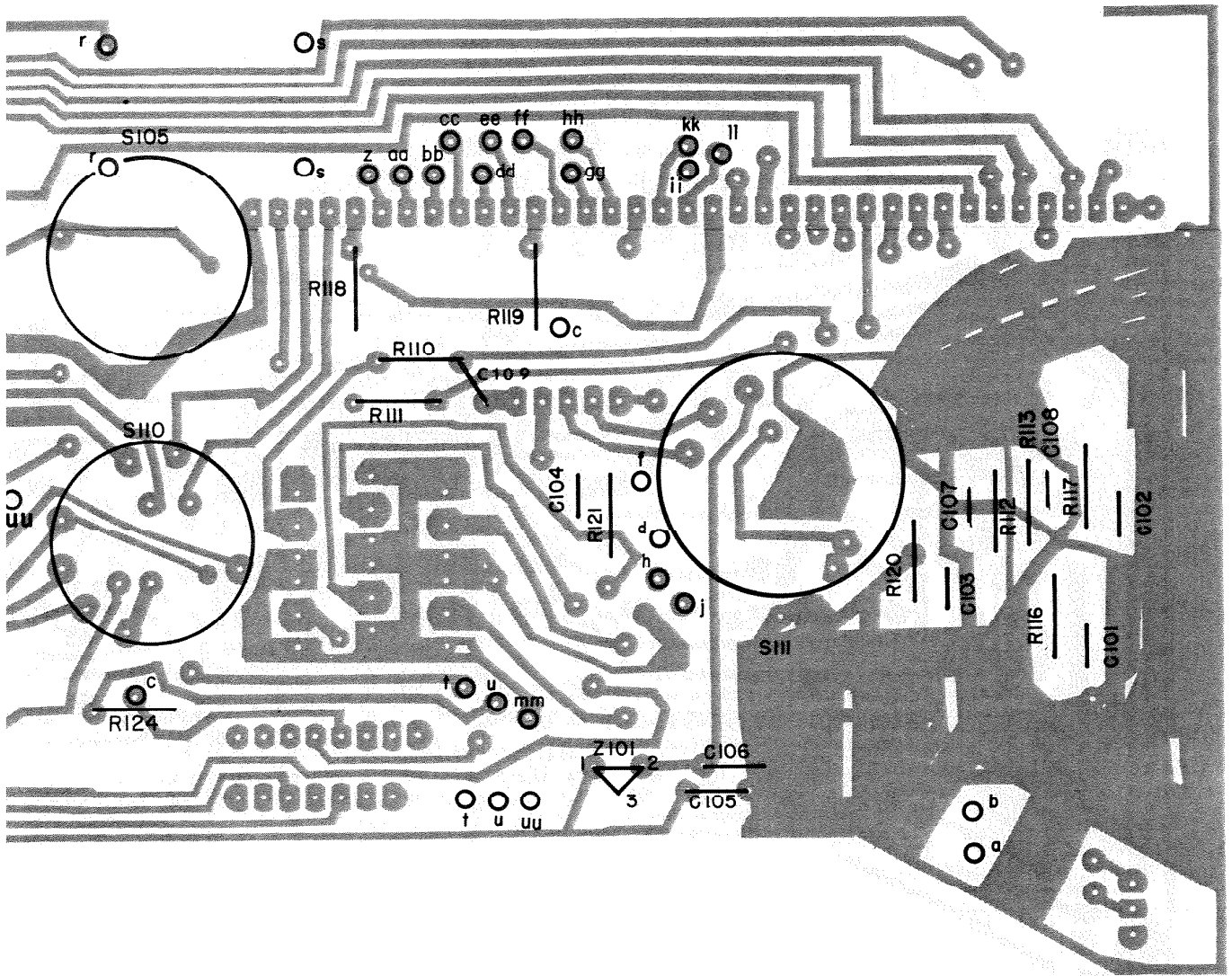

ARD — FRONT VIEW
 COMPONENT LOCATION

FIGURE 23

| Schematic Symbol | NuTone Part No. | Description |
|--|-----------------|---|
| CAPACITORS | | |
| C301 | 35100-174 | 150pf |
| C302, C312 | 35101-142 | 15pf, temperature compensated |
| C303A-C303J | 35092-000 | Variable, AM/FM Ganged Tuning |
| | 42024-000 | Dial Cord/Terminal Assembly |
| | 31208-000 | Spring, Dial Cord Pulley |
| | 39335-000 | Dial Pointer |
| | 39327-000 | Pulley, tuning capacitor |
| | 39135-000 | Cap, tuning capacitor pulley |
| | 31872-000 | Lock Washer, tuning capacitor pulley |
| | 26471-038 | Screw, #6 × 5/16, Ph Pan, Pulley retainer |
| C304, C307, C356 | 35100-120 | .001 |
| C305 | Not Used | |
| C306, C313, C316, C317, C321, C332, C341, C346 | 35100-139 | .01, +80%, -20%, 50WVDC |
| C308, C325, C355 | 35101-140 | 10pf, temperature compensated |
| C309, C326 | 35100-138 | .005 ±20%, 100WVDC |
| C310 | 35101-134 | 3.3pf, temperature compensated |
| C311, C315 | 35100-125 | 220pf |
| C314 | 35101-147 | 1.2pf ±0.25pf temp. compensated |
| C318 | 35076-101 | .22, +80%, -20%, 12WVDC |
| C319 | Not Used | |
| C320, C337, C338 | 35091-109 | 47, +100%, -10%, 16WVDC, Electrolytic |
| C332, C344 | 35101-141 | 5.6pf, temperature compensated |
| C323 | Not Used | |
| C324 | 35101-135 | 7.5pf, temperature compensated |
| C327 | 35101-126 | 1.2pf ±0.25 pf, temp. compensated |
| C328 | 35090-000 | 1-8pf variable, oscillator high-frequency trimmer, 100WVDC/AC |
| C329, C330 | Not Used | |
| C331, C335 | 35076-106 | .1 ±20%, 25WVDC |
| C333, C334, C336, C342 | 35100-141 | .05. +80%, -20%, 50WVDC |
| C339 | 35091-103 | 4.7, +100%, -10%, 25WVDC, Electrolytic |
| C340 | 35076-108 | .02 ±20%, 16WVDC |
| C345 | 35100-175 | 56pf |
| C347-C352 | Not Used | |
| C353 | 35100-173 | .001 |
| C354 | 35100-120 | nn1 |
| FILTERS | | |
| CF301 | 36088-000 | R10.7 MHz. FM IF, Ceramic Vernitron Piezoelectric Div. FM-4 (Preferred) Murata Corp. SFG-10.7MA |
| CF302, CF303 | 36087-000 | 455 KHz. AM IF, Ceramic Murata Corp SFB-455D |
| DIODES | | |
| D301 | 36617-000 | Silicon Switching, 50ma. dc, 75PIV 1N914 Texan Inst. 1N4148 |
| INTEGRATED CIRCUITS | | |
| IC301 | 36623-000 | FM IF, Detector RCA CA3089E S.G.S. ATES TDA-1200 |

| Schematic Symbol | NuTone Part No. | Description |
|-------------------------------|-----------------|--|
| CONNECTORS | | |
| J1 | 39339-101 | Receptacle, 5-pin PC board mounting, Molex type A-2141-5B (voltage and signal connector to parent board. |
| J6 | 39339-105 | Receptacle, 3-pin PC board mounting, Molex type A-2141-3B (tuning signal to tuning meter via parent board) |
| COILS AND TRANSFORMERS | | |
| L301 | 30087-000 | FM Ant. Primary |
| L301 | 30086-000 | FM Ant. Trap |
| L301 | 30096-000 | FM Ant. Secondary |
| L302 | 30097-000 | FM RF Drain Tank |
| L303 | 30088-000 | FM Oscillator |
| L304 | 30092-000 | 10.7 MHz Quadrature Detector Tuning |
| L305 | 30091-101 | 22 microhenry, fixed inductor |
| L306, L307, L308, L311 | 30062-000 | 10.7 MHz. RF Choke |
| | 30073-000 | Coil Form, for L301, L302, and L303 |
| | 31915-000 | Tuning Slug, in coil form for L301, L302, and L303 |
| L309 | 30597-000 | Transformer, AM Ant. |
| L310 | 30598-000 | Transformer. AM Oscillator |
| T301A | 30590-000 | 10.7 MHz. Mixer collector tank. primary |
| T301B | 30591-000 | 10.7 MHz. IF Filter input, secondary |
| T302 | 30589-000 | IF, AM, 455 KHz. |
| TRANSISTORS | | |
| Q301 | 36624-000 | Dual Gate FET, FM RF Ampl. Gen. Inst. MEM615A, MEM614 Motorola MFE130 Texas Inst. 3N203 |
| Q302 | 36578-000 | NPN Epitaxial Planar Silicon, FM Mixer Texas Inst. SKA-4231 Motorola SPS-4448 Nat. Semiconductor SM-43-050 |
| Q303 | 36581-000 | NPN Planar Silicon, FM Oscillator Texas Inst. SKA-4230 Nat. Semiconductor SM-43-050 |
| RESISTORS | | |
| R301 | 33082-564 | 560K |
| R302 | 33082-224 | 220K |
| R303 | 33082-154 | 150K |
| R304 | 33082-391 | 390 |
| R305, R310, R322, R324 | 33082-331 | 330 |
| R306 | 33082-333 | 33K |
| R307, R311 | 33082-392 | 3.9K |
| R308 | 33082-102 | 1K |
| R309 | 33082-103 | 10K (Original Production) |
| R309 | 33082-470 | 47 |
| R312 | Not Used | |
| R313 | 33082-153 | 15K |
| R314 | 33082-104 | 100K |
| R315 | 34043-000 | 500K variable, trim potentiometer, FM Squelch Control |
| R316 | 33082-470 | 47 |
| R317 | Not Used | |
| R318 | 33082-822 | 8.2K |
| R319, R320 | 33082-103 | 10K |
| R328 | | |
| R321, R329 | 33082-182 | 1.8K |
| R323 | 33082-332 | 3.3K |

| Schematic Symbol | NuTone Part No. | Description |
|-------------------------------|-----------------|---|
| R325 | 33082-661 | 660 |
| R326 | 33082-222 | 2.2K |
| R327 | 33082-393 | 39K |
| R330, R332 | 33082-101 | 100 |
| R333 | 33082-183 | 18K |
| MISCELLANEOUS | | |
| | 41648-000 | Coax Cable Assembly, Antennae Lead-in |
| | 39598-003 | RF Shield |
| CONTROL CIRCUIT MODULE | | |
| | 42096-000 | Complete Assembly |
| CAPACITORS | | |
| C401 | 35091-103 | 4.7, +100%, -10%, 25WVDC Electrolytic |
| C402 | 35091-110 | 22, +100%, -10%, 16WVDC Electrolytic |
| C403, C404 | 35091-106 | 2.2, +100%, -10%, 25WVDC Electrolytic |
| DIODES | | |
| D401-D406 | 36617-000 | Silicon, Switching 50madc, 75PIV, Texas Inst. 1N4148 1N914 |
| D407 | 36549-000 | Silicon Rectifier 1Adc, 100PIV, 1N4002 |
| CONNECTORS | | |
| J2A | 39339-103 | Receptacle, 8-pin PC board mounting, Molex type A-2145-8B (connect to P104 on Parent Board) |
| J2B | 39339-105 | Receptacle, 3-pin PC Board mounting, Molex type A-2145-3B (J2B pins 9-11 connect to pins 9-11 of P103 on Parent Board) |
| J2B | 39339-106 | Receptacle, 4-pin PC board mounting, Molex type A-2145-4B (J2B pins 12-15 connect to pins 12-15 of P103 on Parent Board) |
| RELAYS | | |
| K401 | 39336-000 | TALK/LOSTEN. 4PDT Nominal coil voltage: 24Vdc Coil Resistance: 700 ohm $\pm 10\%$ Must Pull-in at 14Vdc American Zettler #AZ429-70-10L Potter Brumfield #R10-E2Z4V700 |
| K402 | 39337-000 | STANDBY, SPST Reed Nominal coil voltage: 12Vdc Max coil voltage: 20Vdc Coil Resistance: 960 ohm $\pm 10\%$ Must Pull-in at 8Vdcz Must Release at 1Vdc New Product Engr. #118-0003-001 |
| TRANSISTORS | | |
| Q401 | 36509-000 | Darlington, PNP Planar Silicon, Motorola MPS-A65 |
| Q402 | 36590-000 | Darlington, NPN Planar Silicon Motorola MPS-A13 |
| Q403 | 36613-000 | NPN Silicon Motorola MPS-A20 Texas Inst. TIS-98 NPC Elect. NPC-069 |
| Q404 | 36606-000 | PNP Silicon Motorola MPS-K71(Yellow) NPC Elect. NPC-079 |

| Schematic Symbol | NuTone Part No. | Description |
|-------------------------------|-----------------|--|
| RESISTORS | | |
| R401, R411 | 33082-182 | 1.8K |
| R402 | 33082-392 | 3.9K |
| R403, R410 | 33082-682 | 6.8K |
| R404 | 33082-472 | 4.7K |
| R405, R416 | 33082-103 | 10K |
| R406 | 33082-332 | 3.3K |
| R407 | Not Used | |
| R408 | 33082-102 | 1K |
| R409 | 33082-561 | 560 |
| R412 | 33082-124 | 120K |
| R413 | Not Used | |
| R414, R417 | 33082-223 | 22K |
| R415 | 33082-473 | 47K |
| R418 | Not Used | |
| R419 | 33082-560 | 56 |
| POWER AMPLIFIER MODULE | | |
| | 42014-000 | Complete Assembly (for original production schematic diagram and PC layout, see publication, Part No. FE980) |
| CAPACITORS | | |
| C501, C502, C506, C507, C512 | 35091-108 | 100, +100%, -10%, 25WVDC Electrolytic |
| C503 | 35055-103 | .1 $\pm 20\%$, 2 50WVDC, Mylar (Original Production) |
| C503 | 35055-101 | .47 $\pm 20\%$, 100WVDC, Mylar (Later Production) |
| C504 | 35100-169 | 2700pf |
| C505 | 35100-134 | 470pf |
| C508, C510, C511 | 35100-127 | .1, +80%, -20%, 100WVDC |
| C509 | 35091-107 | 1000, +100%, -10%, 35WVDC Electrolytic |
| C513 | 35100-127 | .1, +80%, -20%, 100WVDC (Later Production Only) |
| DIODES | | |
| D501 | 36639-000 | 18V $\pm 10\%$, Zener 1N4746, 1N4746A (Original Production) |
| D501 | 36549-000 | Silicon Rectifier, 1Adc, 100PIV 1N4002 (Later Production) |
| D502 | 36549-000 | Silicon Rectifier, 1Adc, 100PIV 1N4002 (Later Production Only) |
| COIL | | |
| L501 | 30062-000 | 1 microhenry choke (Original Production Only) |
| | 8169-W2 | Wire, jumper (used in lieu of L501 in later production units) |
| CONNECTORS | | |
| P501 | 39619-101 | Plug, 5-pin, PC board mounting, Molex type A-2373-5M |
| RESISTORS | | |
| R501 | 33082-104 | 100K |
| R502 | 33082-560 | 56 |
| R503 | 33101-010 | 1 $\pm 10\%$, 1/2 watt, Carbon Composition |
| R504 | 33101-101 | 100 $\pm 10\%$, 1/2 watt, Carbon Composition |
| R505, R508 | 33082-273 | 27K |
| R506 | 33082-395 | 3.9M |
| R507 | 33082-333 | 33K |

| Schematic Symbol | NuTone Part No. | Description |
|--|-----------------|--|
| TRANSISTOR | | |
| Q501 | 36580-000 | NPN Planar Silicon, Low-Noise Texas Inst. SKA-4220 Motorola SPS-1216 National Semiconductor SMO-7329 |
| INTEGRATED CIRCUIT | | |
| Z501 | 36667-000 | Comple audio amplifier, including voltage amplifier, inverter, class B linear output. SGS-ATES TBA810AS |
| | 39622-000 | Heat Sink, for Z501 |
| | 39623-000 | Spacer, heat sink |
| | 31990-015 | Screw, #4-40 X 1/2" Ph. Pan "M" |
| | 11159-003 | Heat Sink Mounting Nut, #4-40 Hex for Heat Sink Mounting Screws |
| DUAL AUDIO PREAMP & INTERCOM PREAMP MODULE | | |
| | 42012-000 | Complete Assembly |
| CAPACITORS | | |
| C601, C603, C607, C614, C615, C618, C619, C626, C627, C633 | 35091-102 | 10, +100%, -10%, 16WVDC, Electrolytic |
| C602 | 35100-163 | 6800pf ±20% |
| C604 | 35100-156 | 2200pf |
| C605, C613 C616, C625, C628 | 35091-103 | 4.7, +100%, -10%, 25WVDC, Electrolytic |
| C606, C617 | 35100-127 | .1, +80%, -20%, 100WVDC |
| C608, C620 | 35091, 104 | 33, +100%, -10%, 25WVDC, Electrolytic |
| C609, C621 | 35055-105 | .0047, 400WVDC, Polyester Film |
| C610, C622 | 35055-106 | .047, 250WVDC, Polyester Film |
| C611, C624 | 35055-107 | .0015, 250WVDC, Polyester Film |
| C612, C623 | 35055-108 | .015, 250WVDC, Polyester Film |
| C629-C632 | 35091-108 | 100, +100%, -10%, 25WVDC, Electrolytic |
| C634-C635 | 35100-157 | 120pf, +80%, -20% |
| C636 | 35100-145 | 1000pf, |
| DIODES | | |
| D601, D602 | 36549-000 | Silicon Rectifier 1Adc, 100PIV 1N4002 |
| CONNECTORS | | |
| P601, P602 | 39619-104 | Plug, 14-pin, PC board mounting, Colex type A-2373-5M |
| TRANSISTORS | | |
| Q601-Q605 Q607-Q610 | 36580-000 | NPN Planar Silicon, Low-Noise Texas Inst. SKA-4220 Motorola SPS-1216 National Semiconductor SMO-7329 |
| Q606, Q611 Q612 | 36613-000 | NPN Silicon Motorola MPS A2U Texas Inst. TIS098 |
| RESISTORS | | |
| R101, R622, R623, R644, R647 | 33082-103 | 10K |
| R602 | 33082-221 | 220 |
| R603 | 33206-683 | 68K ±20%, Metal Film |

| Schematic Symbol | NuTone Part No. | Description |
|--|-----------------|---|
| R604, R611, R636 | 33082-683 | 68K |
| R605, R607, R629, R651 | 33082-274 | 270K 270K |
| R606, R630, R650 | 33082-224 | 220K |
| R608 | 33082-470 | 47 |
| R609 | Not Used | |
| R610, R635 | 33206-224 | 220K ±2%, Metal Film |
| R612, R624, R637, R646 | 33082-104 | 100K |
| R613, R618, R631, R638, R641, R654 | 33082-333 | 33K |
| R614, R633 | 33082-562 | 5.6K |
| R615, R634 | 33206-182 | 1.8K ±20%, Metal Film |
| R616, R639 | 33082-222 | 2.2K |
| R617, R640 | 34050-000 | LEVEL SET Potentiometer 5K ±30%, 1/10 watt, Linear Taper, C.T.S. Corp. V-201-2SS |
| R619, R642 | 33082-183 | 18K |
| R620 | 33101-332 | 3.3K ±10%, 1/2 watt, Carbon Composition |
| R621, R645 | 33082-182 | 1.8K |
| R625, R648 | 33082-153 | 15K |
| R626, R652 | 33082-123 | 12K |
| R627, R653 | 33206-222 | 2.2K ±2%, Metal Film |
| R628, R649 | 33206-104 | 100K ±2%, Metal Film |
| R632 | Not Used | |
| R643 | 33082-332 | 3.3K |
| R655, R658 | 33082-152 | 1.5K |
| R656, R659 | 33082-682 | 6.8K |
| R657 | Not Used | |
| R660, R663 | 33082-101 | 100 |
| R661, R662 | 33082-105 | 1M |
| TRANSFORMER | | |
| T601 | 30692-000 | INTERCOM INPUT Primary: .180 ohms d-c Secondary: 600 ohms d-c Better Coil & Transformer #7486 |
| | 32159-003 | Bracket, T601 mounting |
| FM MULTIPLEX DECODER MODULE | | |
| | 42018-000 | Complete Assembly |
| CAPACITORS | | |
| C701 | 35100-127 | .1, +80%, -20%, 100WVDC |
| C702 | 35091-103 | 4.7, +100%, -10%, 25WVDC, Electrolytic |
| C703 | 35110-106 | 2000pf, ±5%, 100WVDC Silver Mica |
| C704, C705 | 35100-179 | 3300pf |
| C706 | 35100-141 | .05 +80%, -20%, 50WVDC |
| C707 | 35101-149 | 220pf, 100WVDC, Temperature Compensated |
| C708 | 35055-101 | .47 ±20%, 100WVDC, Polyester Film |
| C709, C710 | 35055-104 | .22 ±20%, 100WVDC, Polyester Film |
| C711 | 35091-105 | 470, +100%, -10%, 25WVDC Electrolytic |
| C712 | 35101-150 | 220pf ±5%, 100WVDC, Temperature Compensated |
| C713 | 35091-108 | 100, +100%, -20%, 25WVDC Electrolytic |

(Parts List continued on page 58)

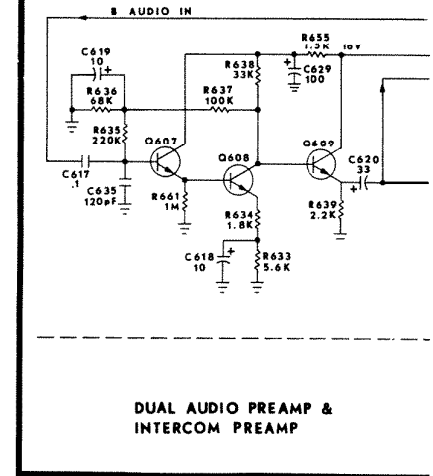
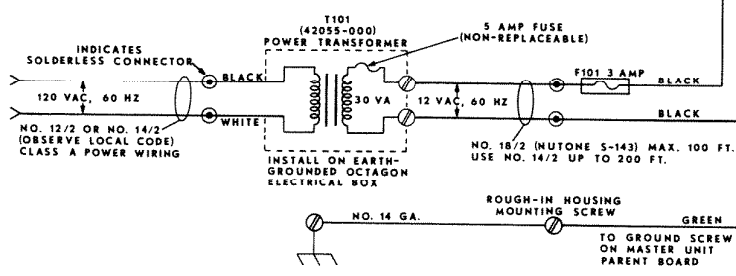
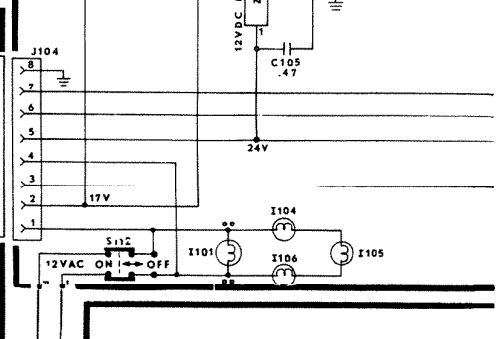
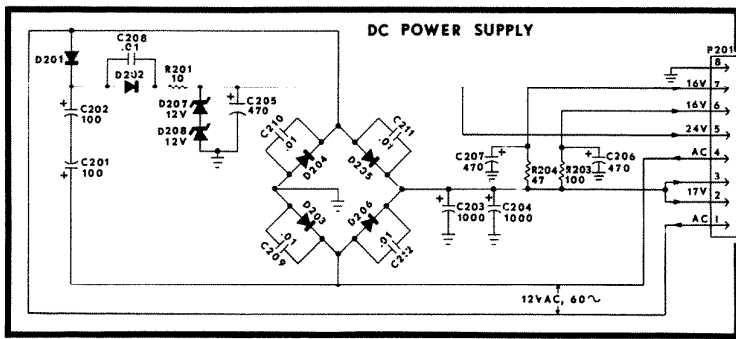
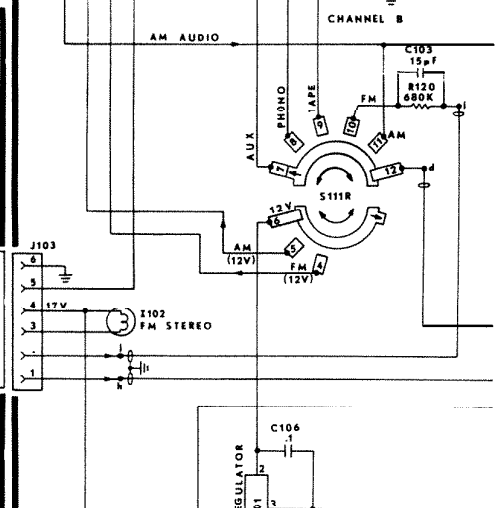
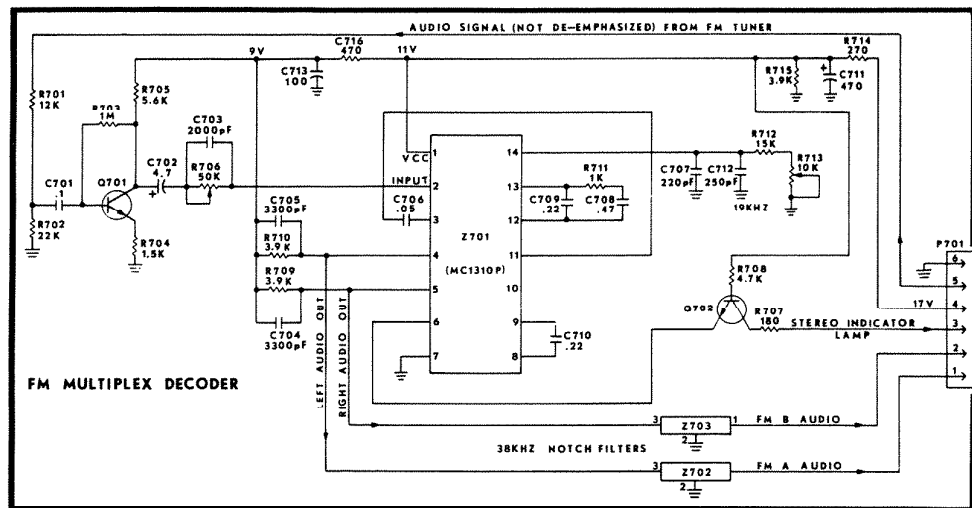
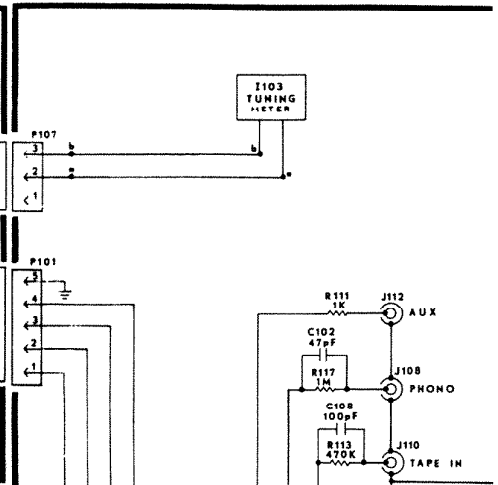
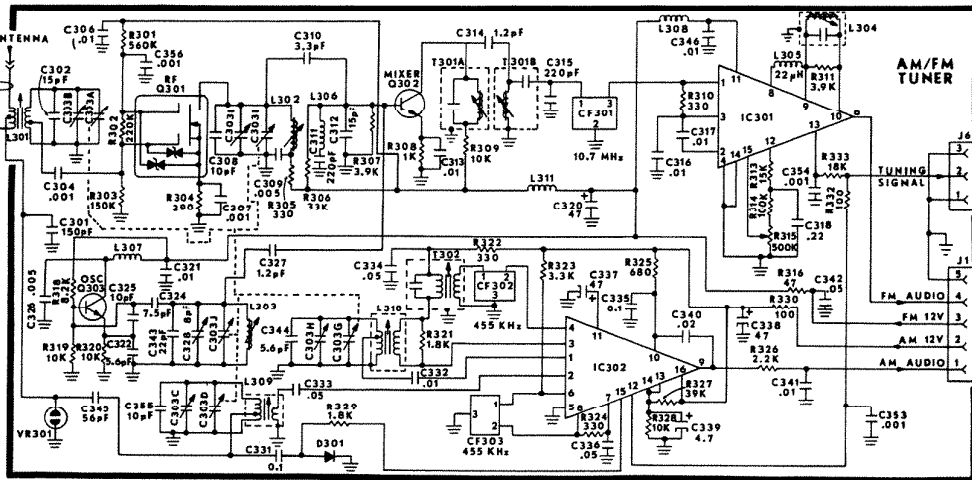

**SM-428 MASTER UNIT
PARENT BOARD**

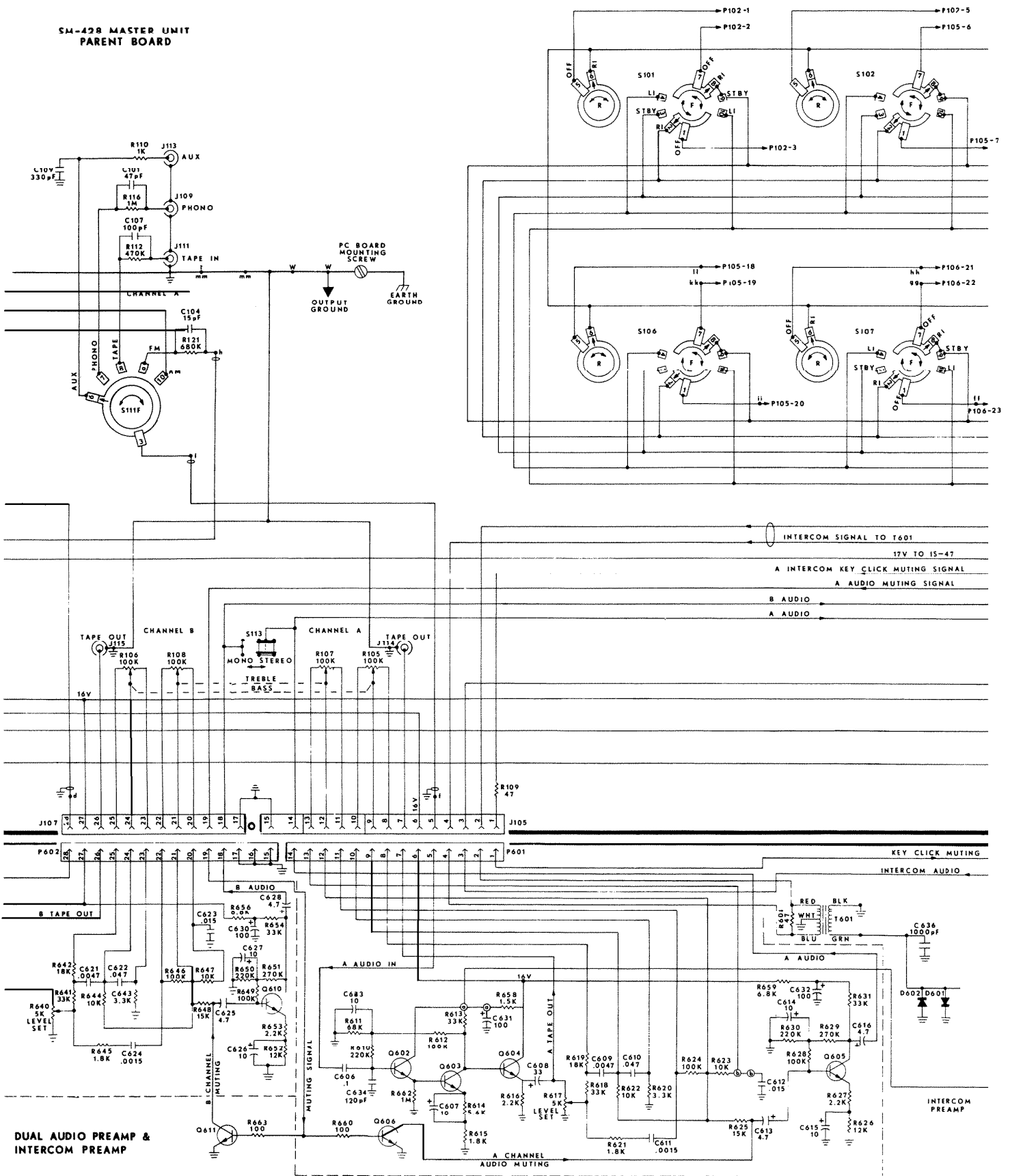

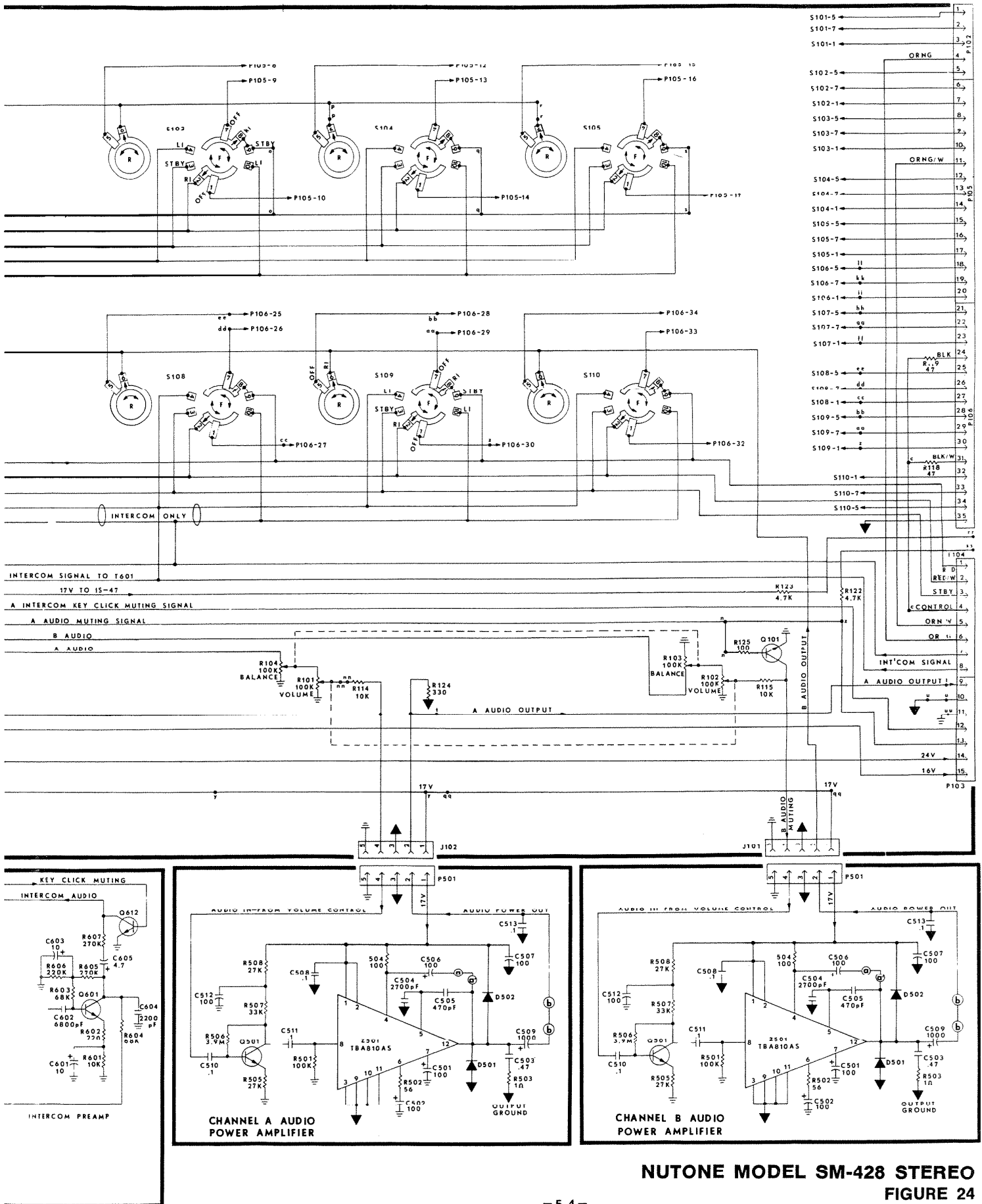

NUTONE MODEL SM-428 STEREO
FIGURE 24

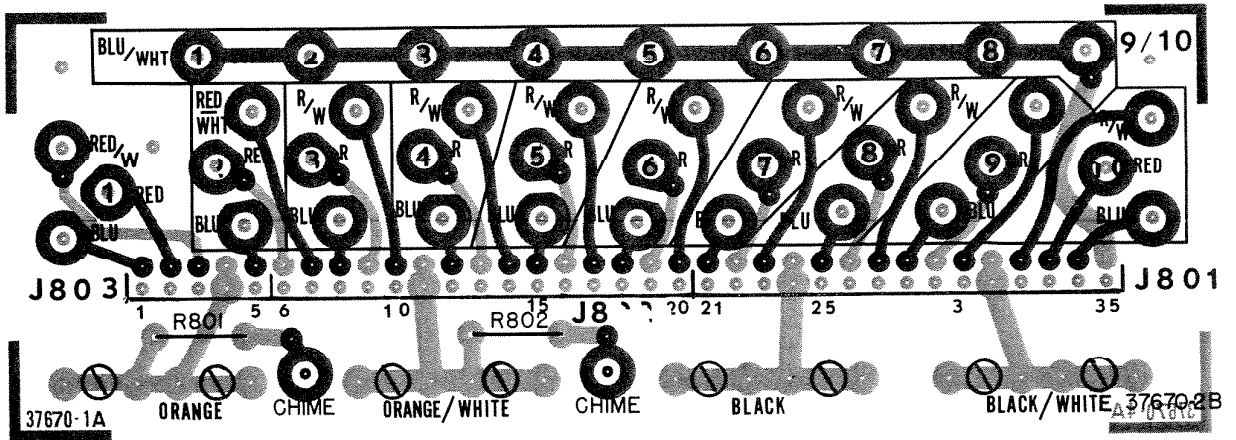

TERMINAL BOARD LAYOUT
DARK FOIL PATH: TOP OF BOARD
LIGHT FOIL PATH: BOTTOM OF BOARD

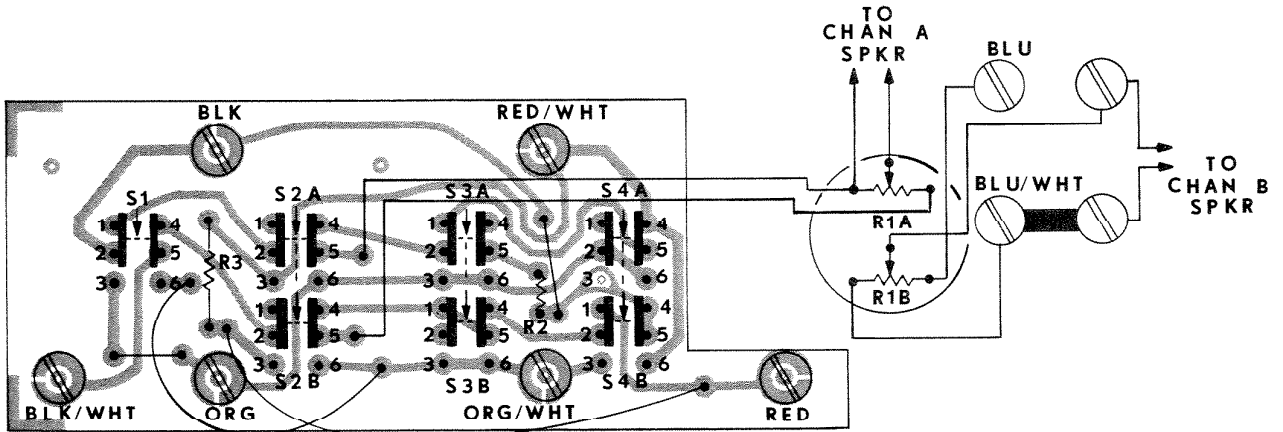

STEREO SPEAKERS CONTROL BOARD PRINTED CIRCUIT COMPONENT CONNECTION

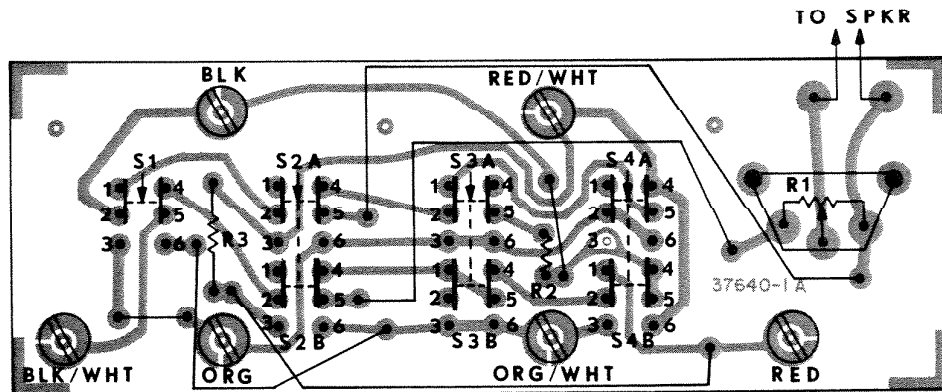

MONO SPEAKER CONTROL BOARD PRINTED CIRCUIT COMPONENT CONNECTION

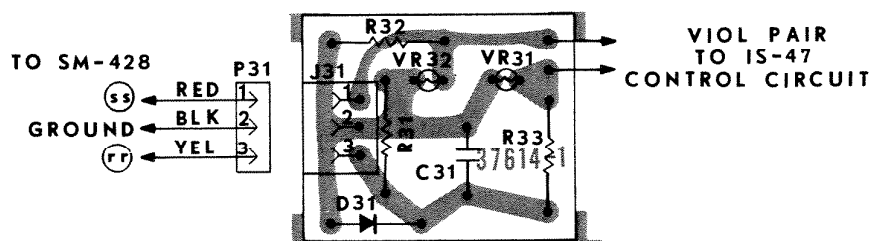

SPEAKER/CLOCK TIMER PROTECTION CIRCUIT FOIL PATH/COMPONENT CONNECTION

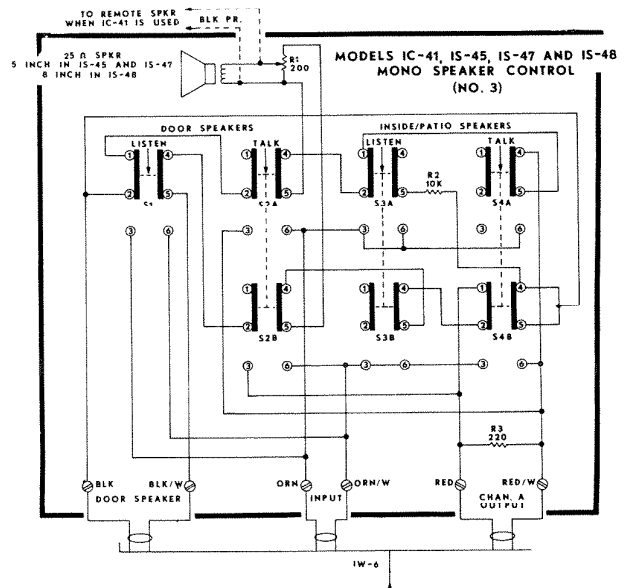
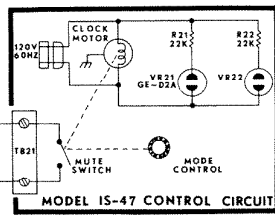
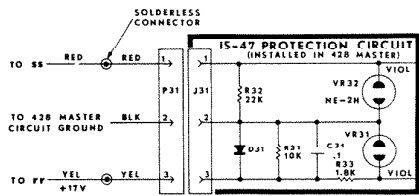
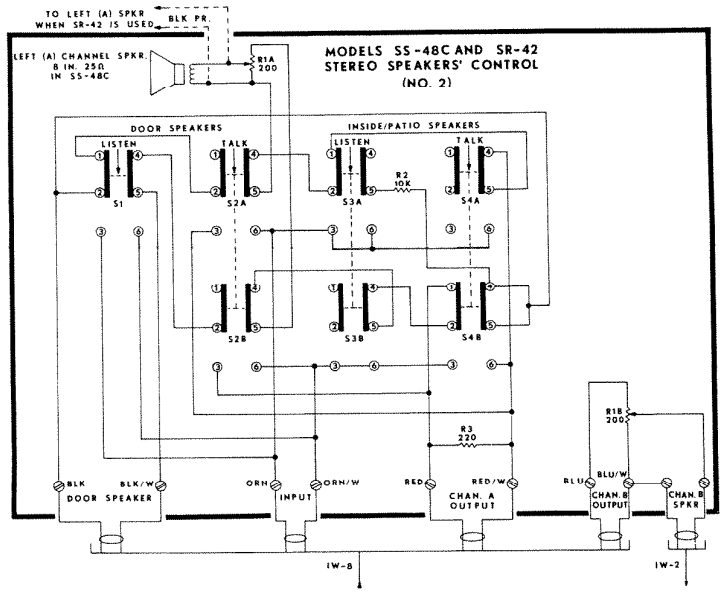
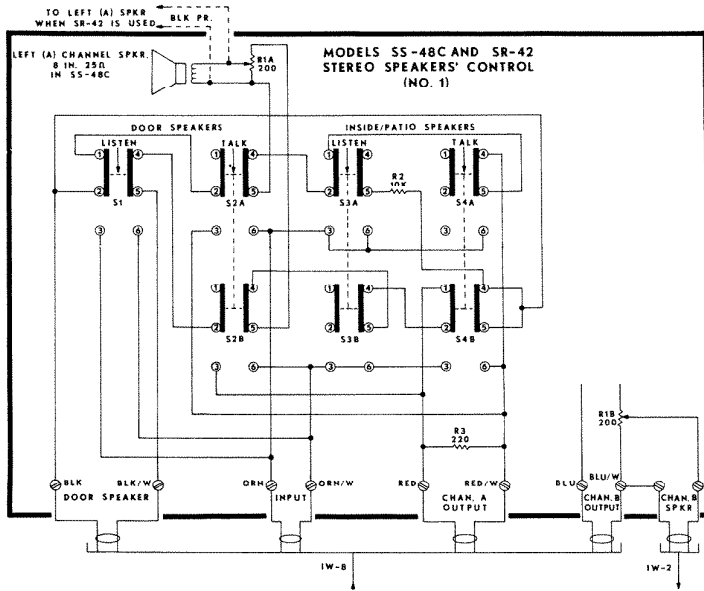

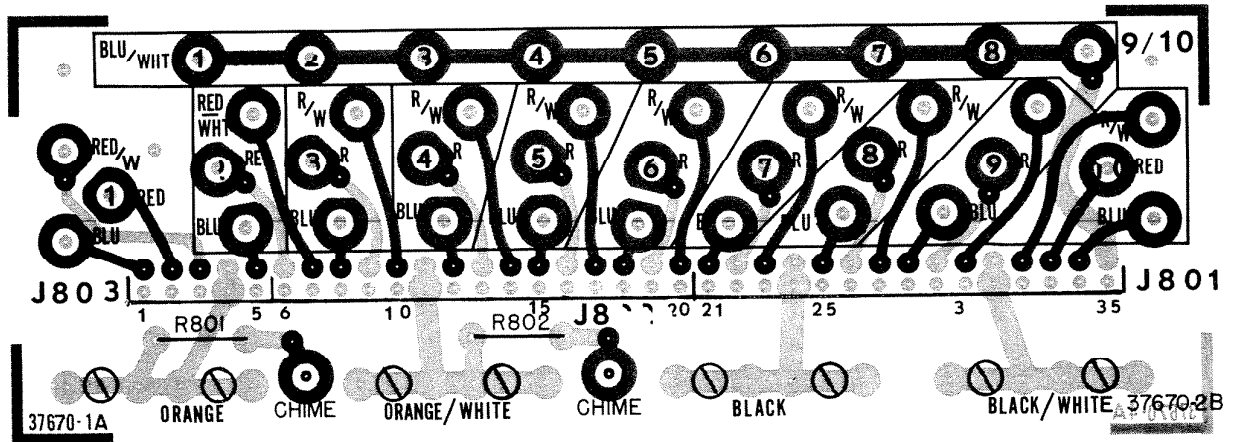

TERMINAL BOARD LAYOUT
DARK FOIL PATH: TOP OF BOARD
LIGHT FOIL PATH: BOTTOM OF BOARD

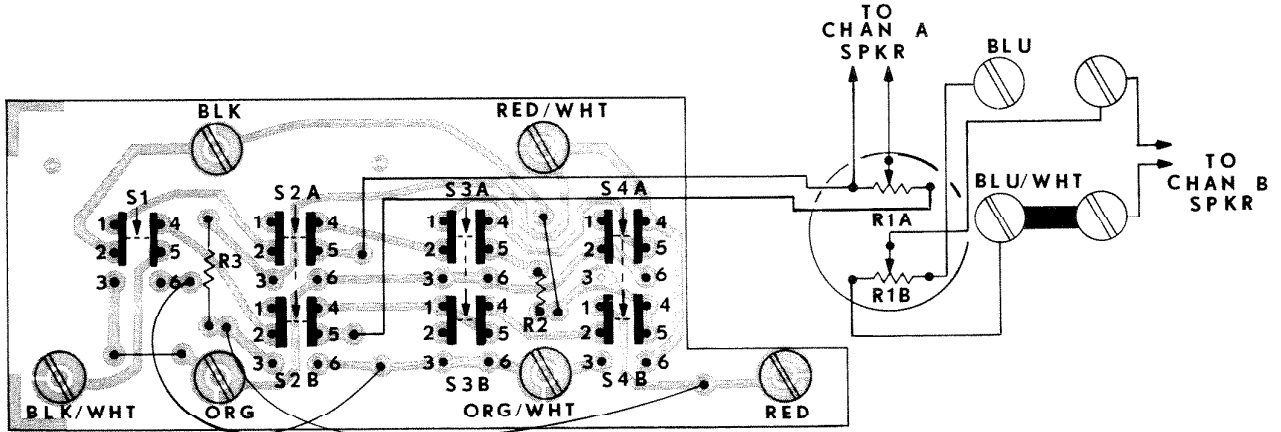

STEREO SPEAKERS CONTROL BOARD PRINTED CIRCUIT COMPONENT CONNECTION

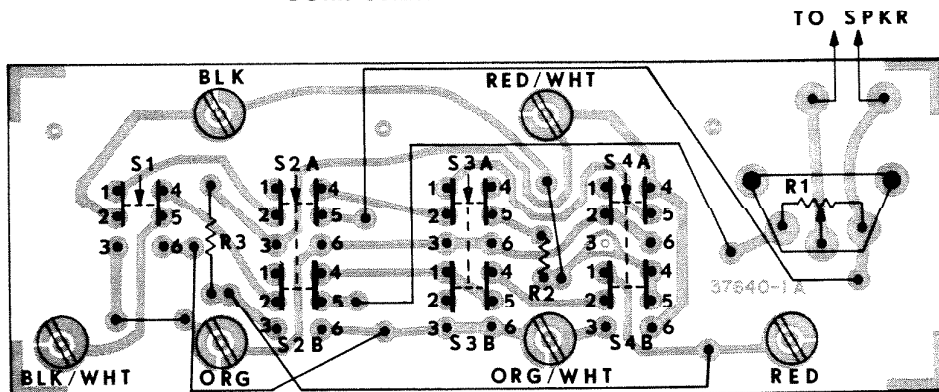

MONO SPEAKER CONTROL BOARD PRINTED CIRCUIT COMPONENT CONNECTION

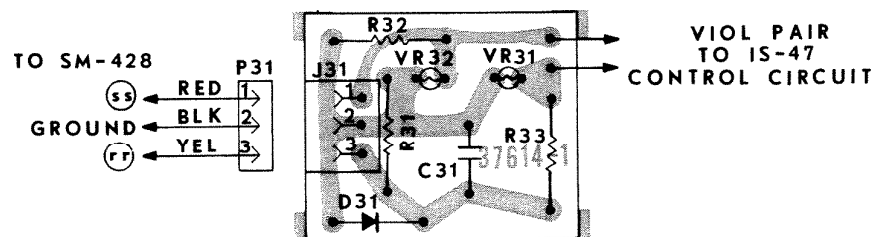

SPEAKER/CLOCK TIMER PROTECTION CIRCUIT FOIL PATH/COMPONENT CONNECTION

| Schematic Symbol | NuTone Part No. | Description |
|------------------------------|-----------------|--|
| CONNECTOR | | |
| P701 | 39619-102 | Plug, 6-pin, PC board mounting, Molex type A2373-6M |
| TRANSISTORS | | |
| Q701 | 36580-000 | NPN Planar Silicon, Low-Noise Texas Inst. SKA-4220 Motorola 3PS-1216 National Semiconductor SMO-7329 |
| Q702 | 36613-000 | NPN Silicon Motorola MPS-A20 Texas Inst. TIS-98 NPC Elect. NPC-069 |
| RESISTORS | | |
| R701 | 33082-123 | 12K |
| R702 | 33082-223 | 22K |
| R703 | 33082-105 | 1M |
| R704 | 33082-152 | 1.5K |
| R705 | 33082-502 | 5.0K |
| R706 | 34041-000 | MPLX DECODER INPUT Rheostat 50K \pm 30%, 1/10 Watt (minimum), Linear Taper C.T.S. Corp. X-201 |
| R707 | 33039-181 | 180 \pm 10%, 1 Watt, Wirewound |
| R708 | 33100-472 | 4.7K \pm 5%, 1/2 Watt, Carbon Comp. |
| R709, R710, R715 | 33082-392 | 3.9K |
| R711 | 33082-102 | 1K |
| R712 | 33082-153 | 15K |
| R713 | 34072-000 | 19KHz. ADJUST Rheostat 10K \pm 20%, 1/2 Watt, Cermet C.T.S. Corp. 362-U |
| R714 | 33082-271 | 270 |
| R716 | 33082-471 | 470 |
| INTEGRATED CIRCUITS | | |
| Z701 | 36668-000 | FM MPLX Decoder Motorola MC-1310-P |
| Z702, Z703 | 37582-000 | 38KHz. Notch Filter Centralab #ES601185 |
| TERMINAL BOARD MODULE | | |
| | 42011-000 | Complete Assembly |
| CONNECTORS | | |
| J801, J802 | 30330 107 | Receptacle, 16-pin, PC board mounting, (terminals 21-35, and 6-20) Molex type A-2145-11B |
| J803 | 39339-101 | Receptacle, 5-pin, PC board mounting, (terminals 1-5) Molex type A-2145-5B |
| RESISTORS | | |
| R801, R802 | 33082-047 | 4.7 |
| | 39613-000 | Brass Terminal Cap for use with Orng, Orng/W, Blk, and Blk/W Terminals |
| | 31669-003 | Screw, #6 \times 3/8" (use with brass terminal caps) |
| | 39209-003 | Screw, #6 \times 3/8" tapping Speaker Wiring Terminals |
| | 39387-003 | Screw, #6 \times 3/8" Terminal Board Mounting |
| MISCELLANEOUS | | |
| | 47743-000 | Protective/Instruction Card |
| | 47588-000 | Installation Instructions |

| Schematic Symbol | NuTone Part No. | Description |
|------------------|-----------------|--|
| | 47589-000 | Homeowner's Operating Manual |
| | 47590-000 | Label, Room Designator. for use with Speaker Operating Mode Switches |
| | 38632-036 | Hinge Bracket. Adjustable leaf for installation in Rough-in Housing |
| | 39326-000 | Hing Pin |
| | 22391-001 | Screw, #8 \times 3/8" PH Tr. Hinge Bracket mounting |
| | 39659-000 | Support Strap |
| | 31987-000 | Hook, use with support strap |
| | 39628-000 | Bracket, Installation, attach to rough-in housing |
| | 25075-000 | Screw, #6 \times 3/8" Slit. RH Installation Bracket mounting |
| | 31526-036 | Screw, #6 \times 1 1/4" PH, Black Master Unit mounting |

MODEL IR-14 ROUGH-IN HOUSING

| | |
|-----------|---|
| 42058-000 | Frame Assembly Complete |
| 39096-000 | Antenna Terminal Strip |
| 40072-000 | FM Antenna Assembly |
| 40676-000 | Envelope Assembly (including 5, #6 \times 5/8" frame mounting screws) |
| 47905-000 | Installation Instruction Sheet |
| 42055-000 | Power Transformer, 120Vac/12Vac @ 30VA |
| 29911-000 | Power Transformer 230M (X302N) FOR EXPORT USE ONLY |

SPEAKERS

| | |
|-----------|---|
| 36106-000 | Speaker, Deluxe, 8-inch, 8-ohm: Used in SS-40 |
| 42076-000 | SS-40 Frame and Grille Assembly |
| 36074-000 | Speaker, 8-inch, 16-ohm, 20-watt peak, Ceramic Magnet, Weatherproof. Used in IS-77; and IS-79 |
| 36089-000 | Speaker, 8-inch, 25-ohm voice coil. Used In: ISA-48D; ISA-48L; SS-48C; SS-48; and IS-78 |
| 36090-000 | Speaker, 5-inch, 25-ohm voice coil. Used In: ISA-16; ISA-17 |
| 36076-000 | Speaker, 3 1/2-inch, 16-ohm, weatherproof: Used in door speakers. |

CONTROLS

MONAURAL

| | |
|-----------|--|
| 41795-000 | Control Board, complete PC Assembly. Used in: ICA-41; ISA-45; ISA-47; ISA-48D; and ISA-48L (See Figure 24) |
| R1 | 34075-000 Variable Resistor, 200-ohm VOLUME CONTROL |
| R2 | 33101-103 10K \pm 10%, 1/2 watt, Carbon Comp. |
| R3 | 33101-221 220 \pm 10%, 1/2 watt, Carbon Comp. |

| Schematic Symbol | NuTone Part No. | Description |
|------------------|-----------------|---|
| S1 | 34637-000 | Switch, DPDT, Push, Momentary; DOOR LISTEN |
| S2, S3, S4 | 34636-000 | Switch, 4PDT, Push, Momentary; DOOR TALK, I/P LISTEN, I/P TALK |
| | 39557-000 | Knob, for Volume Control R1 |
| | 38729-000 | Operating Arm, for talk/listen switches S1; S2; S3; and S4 |
| STEREO | | |
| | 41994-000 | Control Board, complete PC Assembly. Used in: SR-42/ and SS-48C |
| R2 | 33101-103 | 10K \pm 10%, 1/2 watt, Carbon Comp. |
| R3 | 33101-221 | 220 \pm 10%, 1/2 watt, Carbon Comp. |
| S1 | 34637-000 | Switch, DPDT, Push Momentary; DOOR LISTEN |
| S2, S3, S4 | 34636-000 | Switch 4PDT, Push, Momentary; DOOR TALK, I/P LISTEN, I/P TALK |
| | 38729-000 | Operating Arm, for talk/listen switches S1; S2; S3; and S4 |
| R1A, R1B | 34075-000 | Dual, Concentric 200-ohm VOLUME CONTROL |
| | 39607-000 | Knob, outer, Channel A (RIA) Volume Control |
| | 39608-000 | Knob, inner, Channel B (RIB) Volume Control |

| Schematic Symbol | NuTone Part No. | Description |
|---|-----------------|---|
| ISA-47 5-IN. SPEAKER CLOCK TIMER | | |
| CLOCK TIMER PROTECTION CIRCUIT | | |
| | 41600-000 | Complete Assembly |
| C31 | 35100-127 | .1, 100WVDC |
| D31 | 36549-000 | Silicon Rectifier, 1Adc, 100PIV. 1N4002 |
| J31 | 39421-101 | 3-pin Receptacle |
| P31 | 41601-000 | Plug and Wire, complete assembly |
| R31 | 33101-103 | 10K \pm 10%, 1/2 watt, Carbon Comp. |
| R32 | 33101-223 | 22K \pm 10%, 1/2 watt, Carbon Comp. |
| R33 | 33101-182 | 1.8K \pm 10%, 1/2 watt, Carbon Comp. |
| VR31, VR32 | 39438-000 | Neon Lamp, 105-125 Vac/dc G.E. #C2A-ET(NE2H3T) |
| CLOCK & CONTROL CIRCUIT | | |
| | 36094-000 | Digital Clock Assembly |
| | 38611-000 | Ground Strap |
| | 32603-000 | Interlock Plug/Cord |
| | 17351-000 | End Connector |
| | 39407-000 | Knob. MODE SWITCH TIME/ALARM SET |
| R21/VR21 R22/VR22 | 41582-000 | Complete Assembly, lamps and resistors Resistors 22Kohm each. Lamps. 125V, 2.6ma, 1/3 watt G.E. D-2A |